

# 12,8 & 25,6 Volt Lithium-Iron-Phosphate Batteries Smart With Bluetooth

## Why lithium-iron-phosphate?

Lithium-iron-phosphate (LiFePO<sub>4</sub> or LFP) is the safest of the mainstream li-ion battery types. The nominal voltage of a LFP cell is 3,2V (lead-acid: 2V/cell). A 12,8V LFP battery therefore consists of 4 cells connected in series; and a 25,6V battery consists of 8 cells connected in series.

### Rugged

A lead-acid battery will fail prematurely due to sulfation:

- If it operates in deficit mode during long periods of time (i.e. if the battery is rarely, or never at all, fully charged).
- If it is left partially charged or worse, fully discharged (yacht or mobile home during wintertime).

A LFP battery does not need to be fully charged. Service life even slightly improves in case of partial charge instead of a full charge. This is a major advantage of LFP compared to lead-acid.

Other advantages are the wide operating temperature range, excellent cycling performance, low internal resistance and high efficiency (see below).

LFP is therefore the chemistry of choice for demanding applications.

### Efficient

In several applications (especially off-grid solar and/or wind), energy efficiency can be of crucial importance. The round-trip energy efficiency (discharge from 100% to 0% and back to 100% charged) of the average lead-acid battery is 80%.

The round-trip energy efficiency of a LFP battery is 92%.

The charge process of lead-acid batteries becomes particularly inefficient when the 80% state of charge has been reached, resulting in efficiencies of 50% or even less in solar systems where several days of reserve energy is required (battery operating in 70% to 100% charged state).

In contrast, a LFP battery will still achieve 90% efficiency under shallow discharge conditions.

### Size and weight

Saves up to 70% in space

Saves up to 70% in weight

### Expensive?

LFP batteries are expensive when compared to lead-acid. But in demanding applications, the high initial cost will be more than compensated by longer service life, superior reliability and excellent efficiency.

### Bluetooth

With Bluetooth cell voltages, temperature and alarm status can be monitored.

Very useful to localize a (potential) problem, such as cell imbalance.



12,8V 300Ah LiFePO<sub>4</sub> Battery

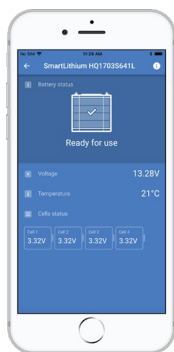

Li-ion app

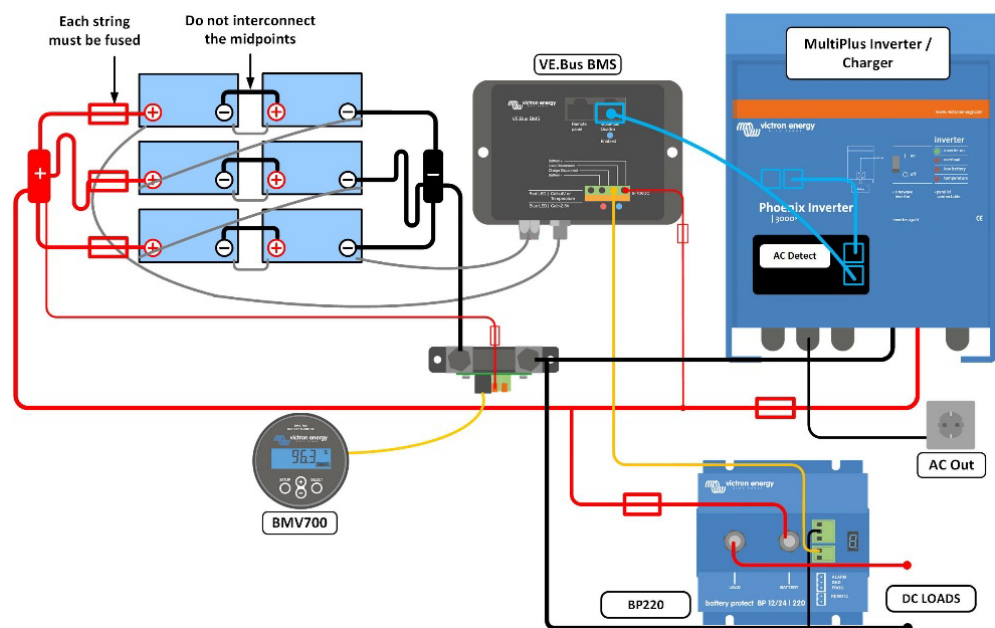

Our LFP batteries have integrated cell balancing and cell monitoring. Up to 5 batteries can be paralleled and up to four 12V batteries or two 24V batteries can be series connected, so that a 48V battery bank of up to 1500Ah can be assembled. The cell balancing/monitoring cables can be daisy-chained and must be connected to a Battery Management System (BMS).

### Battery Management System (BMS)

The BMS will:

1. Generate a pre-alarm whenever the voltage of a battery cell decreases to less than 3,1V (adjustable 2,85 - 3,15 V).
2. Disconnect or shut down the load whenever the voltage of a battery cell decreases to less than 2,8V (adjustable 2,6 V - 2,8 V).
3. Stop the charging process whenever the voltage of a battery cell increases to more than 3,75 V or when the temperature becomes too high.

See the BMS datasheets for more features

Battery specification									
VOLTAGE AND CAPACITY	LFP-Smart 12,8/50	LFP-Smart 12,8/60	LFP-Smart 12,8/100	LFP-Smart 12,8/160	LFP-Smart 12,8/200	LFP-Smart 12,8/300	LFP-Smart 12,8/330	LFP-Smart 25,6/100	LFP-Smart 25,6/200-a
Nominal voltage	12,8V	12,8V	12,8V	12,8V	12,8V	12,8V	12,8V	25,6V	25,6V
Nominal capacity @ 25°C*	50Ah	60Ah	100Ah	160Ah	200Ah	300Ah	330Ah	100Ah	200Ah
Nominal capacity @ 0°C*	40Ah	48Ah	80Ah	130Ah	160Ah	240Ah	260Ah	80Ah	160Ah
Nominal capacity @ -20°C*	25Ah	30Ah	50Ah	80Ah	100Ah	150Ah	160Ah	50Ah	100Ah
Nominal energy @ 25°C*	640Wh	768Wh	1280Wh	2048Wh	2560Wh	3840Wh	4220Wh	2560Wh	5120Wh
*Discharge current ≤1C									
CYCLE LIFE (capacity ≥ 80% of nominal)									
80% DoD	2500 cycles								
70% DoD	3000 cycles								
50% DoD	5000 cycles								
DISCHARGE									
Maximum continuous discharge current	100A	120A	200A	320A	400A	600A	400A	200A	400A
Recommended continuous discharge current	≤50A	≤60A	≤100A	≤160A	≤200A	≤300A	≤300A	≤100A	≤200A
End of discharge voltage	11,2V	11,2V	11,2V	11,2V	11,2V	11,2V	11,2V	22,4V	22,4V
Internal resistance	2mΩ	2mΩ	0,8mΩ	0,9mΩ	0,8mΩ	0,8mΩ	0,8mΩ	1,6mΩ	1,5mΩ
OPERATING CONDITIONS									
Operating temperature	Discharge: -20°C to +50°C    Charge: +5°C to +50°C								
Storage temperature	-45°C to +70°C								
Humidity (non-condensing)	Max. 95%								
Protection class	IP 22								
CHARGE									
Charge voltage	Between 14V/28V and 14,4V/28,8V (14,2V/28,4V recommended)								
Float voltage	13,5V/27V								
Maximum charge current	100A	120A	200A	320A	400A	600A	400A	200A	400A
Recommended charge current	≤30A	≤30A	≤50A	≤80A	≤100A	≤150A	≤150A	≤50A	≤100A
OTHER									
Max storage time @ 25°C*	1 year								
BMS connection	Male + female cable with M8 circular connector, length 50cm								
Power connection (threaded inserts)	M8	M8	M8	M8	M8	M10	M10	M8	M8
Dimensions (hxxwxd) mm	199 x 188 x 147	239 x 286 x 132	197 x 321 x 152	237 x 321 x 152	237 x 321 x 152	347 x 425 x 274	265 x 359 x 206	197 x 650 x 163	237 x 650 x 163
Weight	7kg	12kg	14kg	18kg	20kg	51kg	30kg	28kg	39kg
*When fully charged									