



# Tigo Energy Meter

The Energy meter is required in battery storage installations to provide critical usage data to the inverter. This is used to determine if and when the batteries should be supporting the building's energy needs.

## Features

- ANSI C12.20, Class 1.0 (meets 1% accuracy)
- With clamping 2 CTs

## Benefits

- Supports the EI Energy Storage Solution operating modes.
- Meter data displayed in the EI monitoring platform upon activation, no configuration needed.
- Attached connectors allow the CTs to simply plug into the meter terminals.

## Dimensions

Dimensions (W x D x H)	54.1 x 52 x 87.8mm (2.1 x 2.0 x 3.5in)
Weight	0.2kg (0.44lbs)

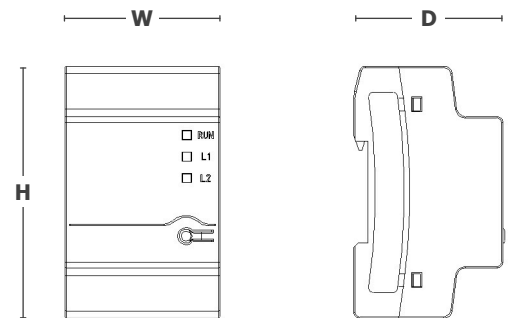

Specifications	Tigo Energy Meter
Nominal Voltage	240/208V
Voltage Range	88%-110%
Nominal Current	200A
Nominal Frequency	60Hz
Voltage Input Type	1P2W,2P3W
Serial Reporting Interval	<1s
Accuracy Class	ANSI C12.20 1.0 (meets 1% accuracy)
Operational Temperature Range	-22°F~131°F (-30°C ~55°C)
Relative Humidity	5~95% Non-condensing
Accessories	2 pcs 200A Rated CT
Communication	RS485



Standard  
Warranty



Powered by Tigo  
Energy Intelligence

### Additional resources



California Energy Commission (CEC) listed as required additional Power Control System (PCS)