Power Optimizer

For Residential Installations

S440 / S500 / S500B



POWER OPTIMIZER

Enabling PV power optimization at the module level

- Specifically designed to work with SolarEdge residential inverters
- Mitigates all types of module mismatch loss, from manufacturing tolerance to partial shading
- Detects abnormal PV connector behavior, preventing potential safety issues*
- Faster installations with simplified cable management and easy assembly using a single bolt
- Module-level voltage shutdown for installer and firefighter safety
- Flexible system design for maximum space utilization
- Superior efficiency (99.5%)
- Compatible with bifacial PV modules

* Functionality subject to inverter model and firmware version

/ Power Optimizer

For Residential Installations

S440 / S500 / S500B

	S440	S500	S500B	UNIT
INPUT				
Rated Input DC Power ⁽¹⁾	440	500		W
Absolute Maximum Input Voltage (Voc)	60		125	Vdc
MPPT Operating Range	8 – 60		12.5 – 105	Vdc
Maximum Short Circuit Current (Isc) of Connected PV Module	14.5	15		Adc
Maximum Efficiency	99.5			%
Weighted Efficiency	98.6			%
Oversoltage Category	II			
OUTPUT DURING OPERATION				
Maximum Output Current	15			Adc
Maximum Output Voltage	60		80	Vdc
OUTPUT DURING STANDBY (POWER OPTIMIZER DISCONNECTED FROM INVERTER OR INVERTER OFF)				
Safety Output Voltage per Power Optimizer	1 ± 0.1			Vdc
STANDARD COMPLIANCE⁽²⁾				
EMC	FCC Part 15 Class B, IEC61000-6-2, IEC61000-6-3, CISPR11, EN-55011			
Safety	IEC62109-1 (class II safety), UL1741			
Material	UL94 V-0, UV Resistant			
RoHS	Yes			
Fire Safety	VDE-AR-E 2100-712:2018-12			
INSTALLATION SPECIFICATIONS				
Maximum Allowed System Voltage	1000			Vdc
Dimensions (W x L x H)	129 x 155 x 30		129 x 155 x 45	mm
Weight (including cables)	655			gr
Input Connector	MC4 ⁽³⁾			
Input Wire Length	0.1			m
Output Connector	MC4			
Output Wire Length	(+) 2.3, (-) 0.10			m
Operating Temperature Range ⁽⁴⁾	-40 to +85			°C
Protection Rating	IP68			
Relative Humidity	0 – 100			%

(1) Rated power of the module at STC will not exceed the Power Optimizer Rated Input DC Power. Modules with up to +5% power tolerance are allowed.

(2) For other connector types please contact SolarEdge.

(3) For ambient temperatures above +70°C power de-rating is applied. Refer to [Power Optimizers Temperature De-Rating Technical Note](#) for details.

PV System Design Using a SolarEdge Inverter ⁽⁵⁾	SolarEdge Home Wave Inverter Single Phase		SolarEdge Home Short String Inverter Three Phase		Three Phase for 230/400V Grid	Three Phase for 277/480V Grid
	Minimum String Length (Power Optimizers)	S440, S500	8	9	16	18
	S500B	6	8	14		
Maximum String Length (Power Optimizers)		25	20	50		
Maximum Continuous Power per String		5700	5625	11250	12750	W
Maximum Allowed Connected Power per String (Permitted only when the power difference between strings is less than 2,000W)		See ⁽⁶⁾	See ⁽⁶⁾	13500	15000	W
Parallel Strings of Different Lengths or Orientations						Yes

(5) It is not allowed to mix S-series and P-series Power Optimizers in new installations.

(6) If the inverter's rated AC power ≤ maximum nominal power per string, then the maximum power per string will be able to reach up to the inverters maximum input DC power.

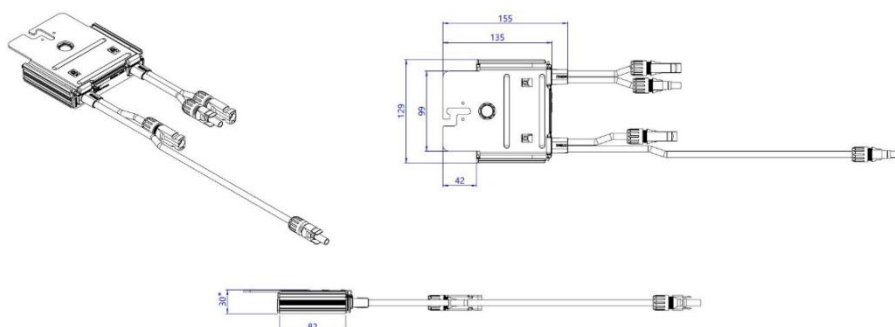

* 45mm for S500B