

# Application Note – HD-Wave Inverters with Built-In RGM & Consumption Monitoring for North America

## Version History

- Version 1.1, January 2021 – new slim-profile CT
- Version 1.0, March 2020 – first version

## Contents

Application Note – HD-Wave Inverters with Built-In RGM & Consumption Monitoring for North America.....	1
Introduction .....	1
Installation Prerequisites .....	2
Required Equipment .....	2
CT Installation .....	3
Configuration .....	7
Monitoring the Meter .....	8
Meter Specification.....	9

## Introduction

The SolarEdge HD-Wave Inverter with **built-in production RGM and consumption monitoring** supports revenue grade (C12.20) production metering. The consumption function requires the installation of one or two external CTs. This application note describes how to prepare the inverter for consumption monitoring.

## Installation Prerequisites

The following conditions are required for the inverter to support the consumption monitoring option:

- The inverter must be a SetApp-enabled inverter.
- The inverter must have one of the following part numbers:
  - SExxxH-US000Bx14: Single phase inverter with HD-wave technology
  - SExxxH-US000Bx34: EV-charging single phase inverter
  - SExxxH-USS3BBx14: StorEdge inverter with HD-Wave technology

## Required Equipment

- Current Transformers (CTs) , purchased separately from SolarEdge, 20 units per package:
  - Slim CTs: SECT-SPL-225A-T-20
  - Split core CTs: SEACT0750-200NA-20, SEACT1250-400NA-20
- Adapter cable required for non-neutral grids, purchased separately from SolarEdge: ADPTR-CABLE-KIT-K1 (5 units per package)
- Twisted pair CT Extension cable, to be purchased separately. The required cable length depends on the distance between the inverter and the service panel, but should not exceed 21 feet. Cable requirements are as follows:
  - Twisted pairs
  - Voltage Rating: 600V
  - Minimum gauge: 24 AWG
  - Maximum gauge: 14 AWG
- Shielded CT Extension cable, to be purchased separately. The shielded extension cable connects the CT to the inverter via the AC conduit. The required cable length depends on the distance between the inverter and the service panel. Cable requirements are as follows:
  - Shielded cable containing two twisted pairs (one per CT)
  - Voltage Rating: 600V
  - Minimum gauge: 24 AWG
  - Maximum gauge: 14 AWG

## CT Installation

The wiring that connects the CT(s) to the meter is routed via the AC conduit, together with the AC wires. The CT-to-meter wiring requires use of a shielded CT extension cable.

Wire the meter in accordance with one of the connection diagrams below:

- Split-phase grid with neutral
- Split-phase grid without neutral

### CTs in a Split-Phase Grid with Neutral

In a split-phase grid with neutral, two CTs are installed as illustrated in the figure below.

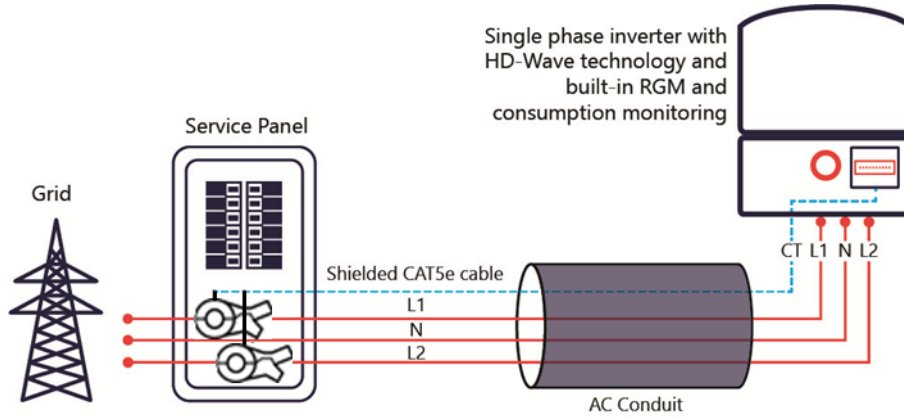

Figure 1: Split Phase Grid with Neutral

### CTs in a Split-Phase Grid without Neutral

In a split-phase grid *without neutral*, one CTs is installed as illustrated in the figure below.

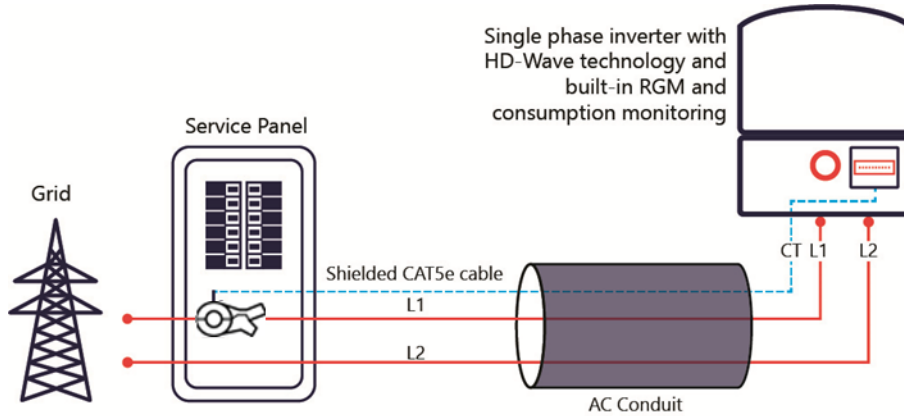

Figure 2: Split Phase Grid without Neutral

## Installing the CTs

→ To install the CTs:

1. Power off the inverter and disconnect its main circuit breaker.
2. Attach the CTs as to the relevant AC wires:
  - For distances of up to 21 feet between the inverter and the service panel, a twisted pair lead wire can be used.
  - For distances of over 21 feet between the inverter and the service panel, attach the CTs to the relevant AC wires as shown in the diagrams above.



### NOTE

When attaching the CT to the conductor to be measured, the arrow on the CT should point in the direction of the current source.

3. Cut the CT's black-and-white twisted wire pair to the required length (leaving some additional spare length), and connect the pair to the shielded CT extension cable (CAT5e or any other shielded wire), splicing them using a crimping tool, as shown in the figure below.

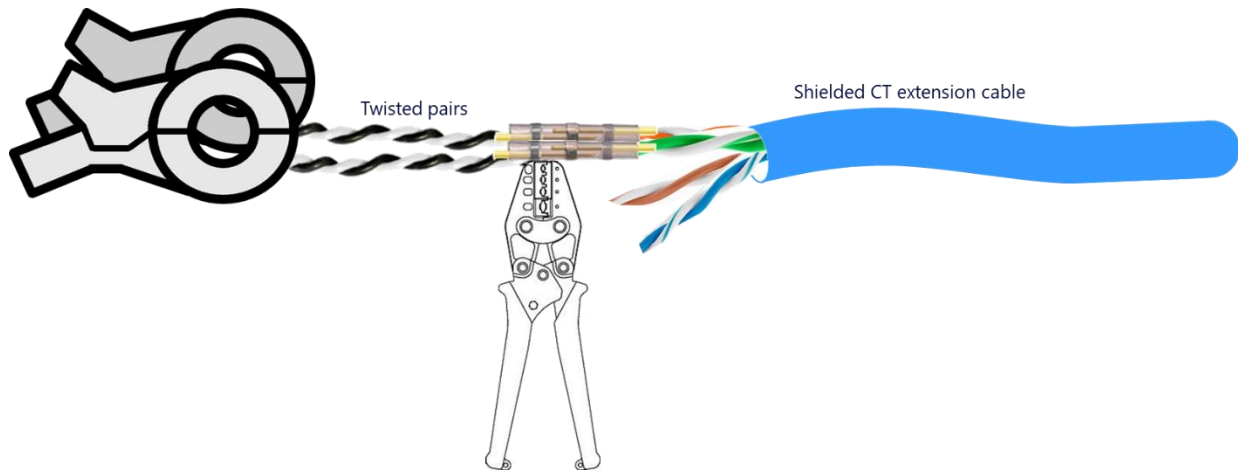

Figure 3: Connecting the CT wires to the shielded CT extension cable



### NOTE

Do not use the method of twisting the wires and taping them together. This type of connection is not reliable and the wires may eventually disconnect from each other.

4. Connect the AC wiring – L1, L2, and N (if required) – to the designated terminal block as shown in Figure 4 below.

5. Run the shielded extension CT cable in the AC conduit and through the knockout of the DC Safety Unit.

**NOTE**

The CT's twisted pair should *not* be run via the AC conduit, as this will affect the quality of the measurements. Only shielded wire should be run in the AC conduit.

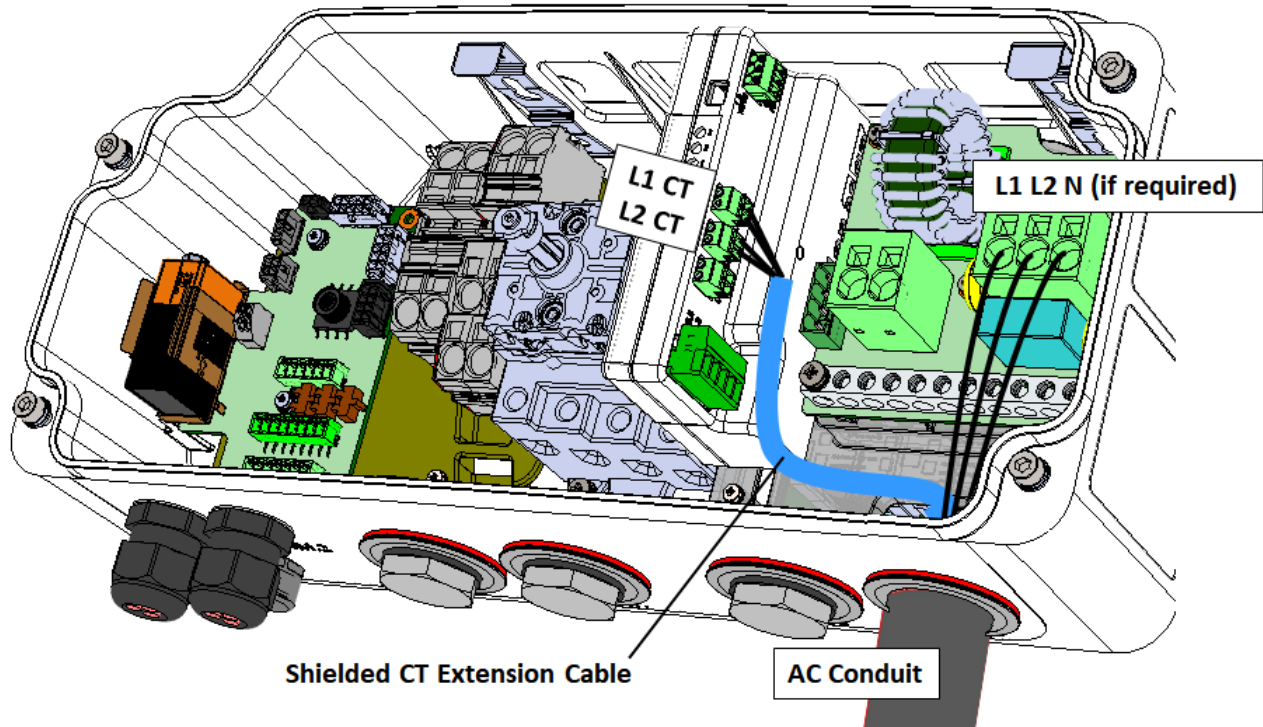

Figure 4: AC and CT Wiring Diagram

**NOTE**

The above figure shows only the wiring that is to be connected by the installer. Factory pre-wired meter cabling does not appear in the diagram.

- Connect the CT wires from the shielded extension cable to the meter. Make sure to connect each phase's CT to the corresponding meter terminal blocks (L1 CT and L2 CT), as shown in the figure below.

**NOTE**  
The CT extension cable's shielding should be left unconnected at both ends.

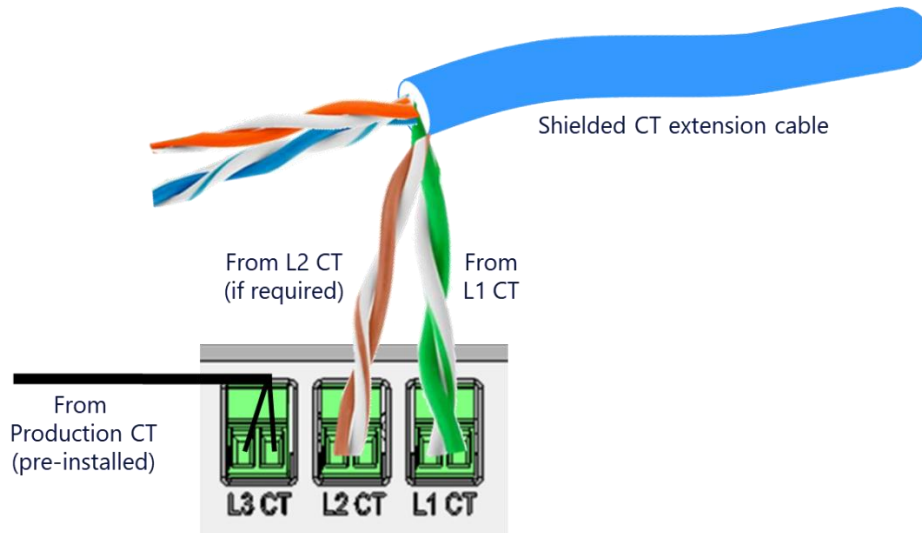

Figure 5: Connecting the CT Wires to the Meter

**NOTE**  
The meter's RS485 wiring is factory pre-installed and should be left unchanged.

- In a non-neutral grid, take the following actions:
  - Make sure that only the L1 and L2 wires are connected to the AC terminal block (N should not be connected).
  - Make sure that only one CT is installed. It should be connected to the L1 CT terminal block, as shown in Figure 2 above.
  - Detach the AC terminal block from the meter, and attach the non-neutral grid adapter cable in its place. Then attach the AC terminal block to the other side of the adapter cable, as shown in Figure 6.

**NOTE**  
The non-neutral grid adapter cable (ADPTR-CABLE-KIT-K1) is *not* supplied with the inverter and must be purchased separately. For more information, contact your SolarEdge representative.

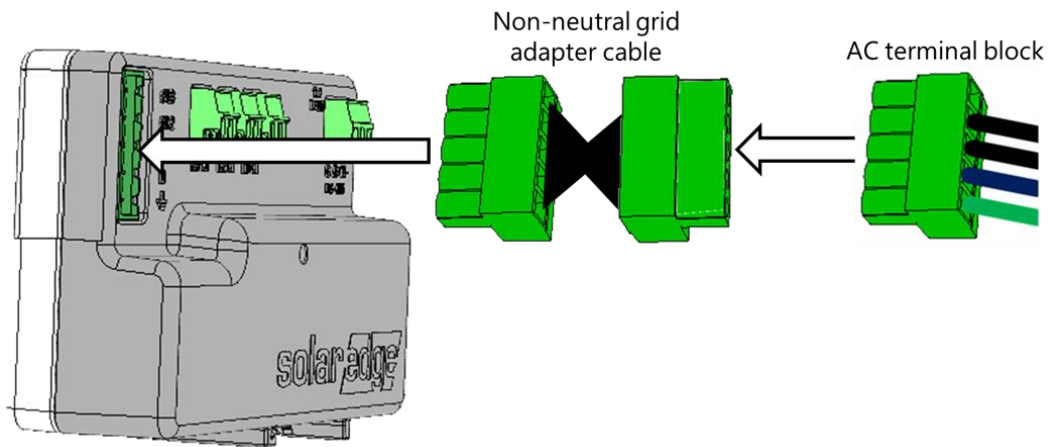

Figure 6: For non-neutral grid: Insert the adapter cable between the meter's AC socket and the wired AC terminal block

## Configuration

The meter's factory default function setting is **Inverter Production + E/I**.

- Production metering is operational at all times (as long as inverter is powered on).
- The consumption monitoring function becomes operational when configured as **Inverter Production + E/I**, and the **CT Rating** is set to a non-zero value.

### → To configure the meter for consumption monitoring using SetApp:

1. Make sure that the **Meter Function** is set to **Inverter Production + E/I** (default factory setting).
2. Select **CT Rating** for the meter and enter the current transformer's rating in amperes (default is 0A). The consumption monitoring function becomes operational once the default setting is changed to a non-zero value.



#### NOTE

The CT rating for L3 (used for production metering) is set to 50A by default, and is not configurable.

3. Select **Commissioning** → **RS485-1** → **Meter x** (the meter number), and configure the following settings.
  - **AC Cable Gauge:** 6 - 14 AWG (default is 8 AWG).
  - **AC Conduit Length:** 0 - 100 feet (default is 20 feet).

### → To deactivate the consumption monitoring function using SetApp:

1. To stop consumption monitoring, the user should set the **Meter Function** to **Production**.



#### NOTE

Auto-activation is supported only when the meter's function is set to **Inverter Production + E/I**.

### → To verify that the meter is configured for production and consumption monitoring, using SetApp:

1. From the main menu, select **Communication**, and verify that Meter1 is connected to RS485-1.
2. Verify that the following settings are configured:
  - **RS485 Protocol:** Modbus (Multi-Device).
  - **Function:** Inverter Production + E/I.
  - **Meter Protocol:** SolarEdge.
  - **Device ID:** 1. Note: ID DIP switch settings on the meter are factory-set to address 1.
  - **CT Rating** should be set to the current transformer's rating in amperes.
3. All other settings mentioned above, including: AC cable gauge and AC conduit length, should be properly configured.

## Monitoring the Meter

### LEDS

The meter utilizes the LEDs on the top of the unit in order to indicate current status.



**NOTE**

The LEDs can be viewed only when the DC Safety Unit is open.

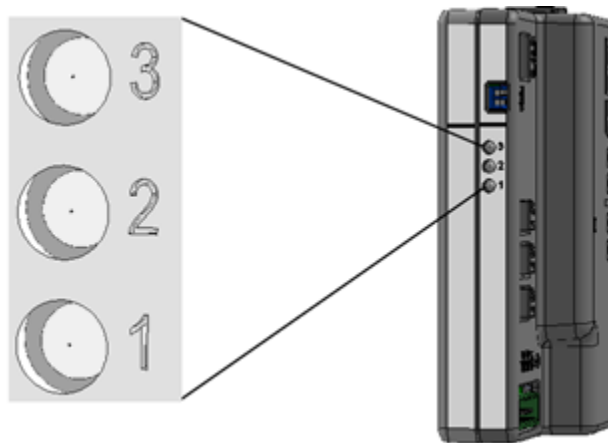

LED #	Color	Function	Indication
1	Green	Operational status	Blinking ON/OFF - normal operation
2	Yellow	RS485 Modbus communication	Blinking ON/OFF - communication OK
3	Yellow	Energy management	Single blink when the meter reads an energy change of ~1 kWh.



## Meter Specification

Meter type	Production and Consumption		
<b>Electrical Characteristics</b>			
Nominal voltage range	208 to 240 (line-to-line) 120 to 277 (line-to-neutral)		Vac
Operating voltage range	187 to 264 (line-to-line) 108 to 305 (line-to-neutral)		Vac
AC Frequency	55 to 65		Hz
Grid supported	Single phase (split phase) with or without neutral: L1 / L2 / N / PE and L1 / L2 / PE		
Power consumption	< 3W		W
Over-voltage protection	CAT III @ 600V		
Accuracy RGM (CT3, L1/L2)	ANSI C12.20 class 0.5 (with Solid core CT) IEC 62053-22 Class 0.5S; IEC 62053-23 Class 2		
Accuracy E/I meter (CT1/CT2, L1/L2) <sup>(1)</sup> 1-5% of 200A CT (split core), 1-2.5% of 400A CT (split core)  5-100% of 200A CT (split core), 2.5-100% of 400A CT(split core)  1-4% of 250A CT (flexible coil), 4-100% of 250A CT (flexible coil)	±2  ±1  ±6 <sup>(2)</sup> ±5 <sup>(2)</sup>		%
<b>Current Transformer</b>			
Nominal Input CT1/CT2 (at CT Rated Current)	CT1, CT2: 0.333		Nominal Vac RMS
Applicable CT1/CT2 (E/I input)	Split core: 200A, 225A, 400A Flexible coil: 250A, 400A		
Dimensions Internal/External	For Rated RMS Current: 200 A	For Rated RMS Current: 400 A	
	Internal: 0.8 x 0.8 / 20 x 20 External: 2.4 x 2.4 / 61 x 61	Internal: 1.26 x 1.83 / 32 x 46.5 External: 3.3 x 4.5 / 83.4 x 114	Inch/mm
225A slim CT See the datasheet for specifications: <a href="https://sparc.canto.global/direct/document/16u5j230st7iffp72oi3u9cv3d/ck75U8tdRs8gxNGiEai8kte6TGg/origin.al?content-type=application%2Fpdf&amp;name=Current+Transformer_DS_ROW.pdf">https://sparc.canto.global/direct/document/16u5j230st7iffp72oi3u9cv3d/ck75U8tdRs8gxNGiEai8kte6TGg/origin.al?content-type=application%2Fpdf&amp;name=Current+Transformer_DS_ROW.pdf</a>			
<b>Communication</b>			
Physical port	3 wire terminal block		
Interface	RS485 half-duplex, 3 wires (A, B, Gnd)		
Protocol	MODBUS RTU		
Register update resolution	Power register < 200		ms
	All other registers < 4		Sec



Mechanical		
Meter mounting	Inverter DIN rail, built-in	
Connectors	Euroblock-style pluggable terminal blocks	
Wire AWG/cross section range		
AC voltage Terminal Block	up to 12 / 2.5	AWG/mm <sup>2</sup>
Communication Terminal Block	24 / 0.2 to 14 / 2	AWG/mm <sup>2</sup>
Current Transformer Terminal Block	24 / 0.2 to 14 / 2	AWG/mm <sup>2</sup>
Operating Temperature Range	-40 to +140 / -40 to +60	°F/°C
Certifications		
Safety	UL 61010-1; CAN/CSA-C22.2 No. 61010-1-04; IEC 61010-1	
Immunity	EN 61326: 2002; EN 61000-4-2; EN 61000-4-3; EN 61000-4-4; EN 61000-4-5; EN 61000-4-6; EN 61000-4-11	
Emissions	FCC Part 15, Class B; EN 55022: 1994, Class B	

<sup>(1)</sup> Relates to energy measurement

<sup>(2)</sup> When using a flexible coil CT with an accuracy-level range of  $\pm 5\%$