



# RB40

Voltage: 12.8V | Capacity: 40 Ah | Energy: 512 Wh

LITHIUM IRON PHOSPHATE BATTERY **LiFePO<sub>4</sub>**

## ELECTRICAL SPECIFICATIONS

Nominal Voltage	12.8 V
Nominal Capacity	40 Ah
Capacity @ 25A	96 min
Resistance	≤50 mΩ @ 50% SOC
Efficiency	99%
Self Discharge	<3% per Month
Maximum Modules in Series	4

## DISCHARGE SPECIFICATIONS

Maximum Continuous Discharge Current	40 A
Peak Discharge Current	80 A (7.5 s ±2.5 s)
BMS Discharge Current Cut-Off	170 A ±20 A (20 ±5 ms)
Recommended Low Voltage Disconnect	11 V
BMS Discharge Voltage Cut-Off	8 V (2.0 ±0.08 vpc) (140 ±60 ms)
Reconnect Voltage	10 V (2.5 ±0.1 vpc)
Short Circuit Protection	200-600 μs

## TEMPERATURE SPECIFICATIONS

Discharge Temperature	-4 to 140 °F (-20 to 60 °C)
Charge Temperature*	-4 to 113 °F (-20 to 45 °C)
Storage Temperature	23 to 95 °F (-5 to 35 °C)
BMS High Temperature Cut-Off	176 °F (80 °C)
Reconnect Temperature	122 °F (50 °C)

\*Refer to charge currents below 32°F (0°C)

## MECHANICAL SPECIFICATIONS

Dimensions (L x W x H)	7.8 x 6.5 x 6.8" 197 x 166 x 173 mm
Weight	11.9 lbs (5.4 kg)
Terminal Type	M8 x 1.25 x 12mm
Terminal Torque	80 - 100 in-lbs (9 - 11 N-m)
Case Material	ABS
Enclosure Protection	IP66
Cell Type - Chemistry	Cylindrical - LiFePO <sub>4</sub>

## CHARGE SPECIFICATIONS

Recommended Charge Current	2 A - 20 A
Maximum Charge Current	40 A
Charge Current 14 to 32 °F (-10 to 0 °C)	≤0.1 C
Charge Current -4 to 14 °F (-20 to -10 °C)	≤0.05 C
Recommended Charge Voltage	14.2 V - 14.6 V
BMS Charge Voltage Cut-Off	15.2 V (3.8 ±0.025 vpc) (1.1 ±0.4 s)
Reconnect Voltage	14.4 V (3.6 ±0.050 vpc)
Balancing Voltage	14.4 V (3.6 ±0.025 vpc)

## COMPLIANCE SPECIFICATIONS

Certifications	UN38.3 (battery) CE (battery) UL1642 & IEC62133 (cells)
Shipping Classification	UN 3480, CLASS 9

## DIMENSIONAL SPECIFICATIONS

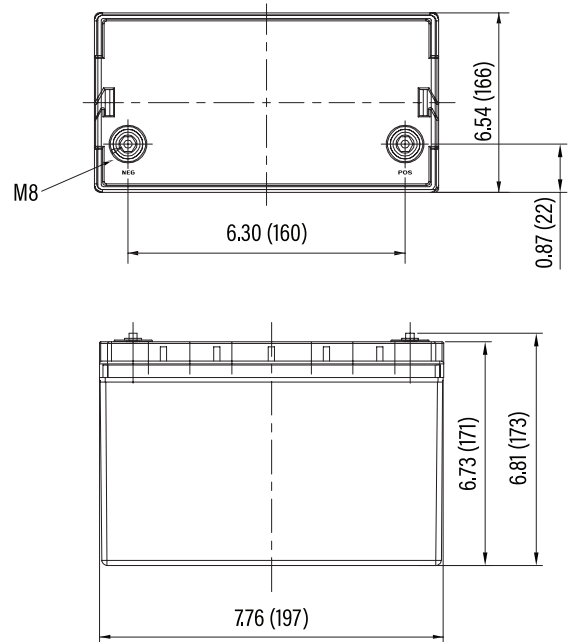



# RB40

Voltage: 12.8V | Capacity: 40 Ah | Energy: 512 Wh

LITHIUM IRON PHOSPHATE BATTERY **LiFePO4**

## PERFORMANCE CHARACTERISTICS

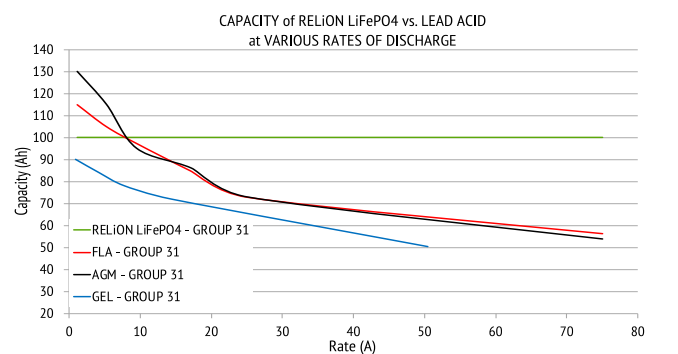
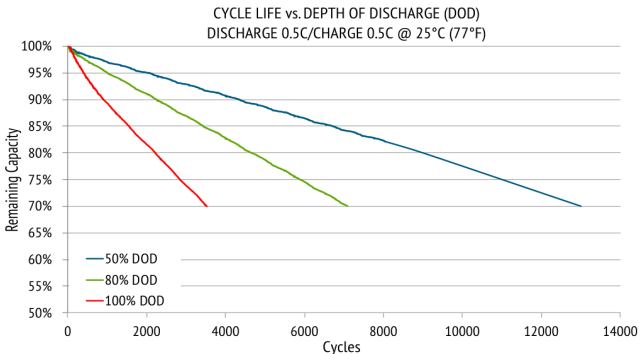
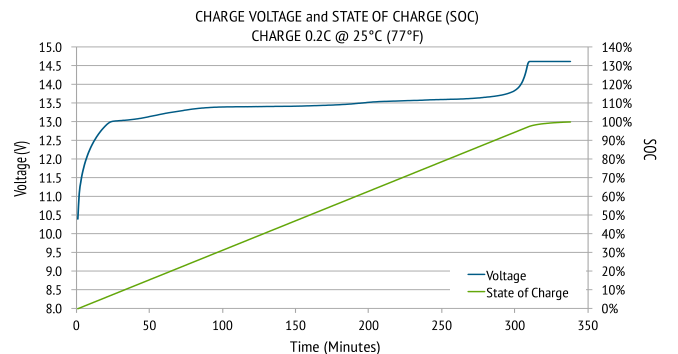

+