



# RB300-LT

Voltage: 12.8V | Capacity: 300 Ah | Energy: 3840 Wh | Group: 8D

LITHIUM IRON PHOSPHATE BATTERY **LiFePO<sub>4</sub>**

ELECTRICAL SPECIFICATIONS	
Nominal Voltage	12.8 V
Nominal Capacity	300 Ah
Capacity @ 25A	720 min
Resistance	≤30 mΩ @ 50% SOC
Efficiency	99%
Self Discharge	<3% per Month
Maximum Modules in Series	1

DISCHARGE SPECIFICATIONS	
Maximum Continuous Discharge Current	100 A
Peak Discharge Current	200 A (7.5 s ±2.5 s)
BMS Discharge Current Cut-Off	280 A ±50 A (9 ±4 ms)
Recommended Low Voltage Disconnect	11 V
BMS Discharge Voltage Cut-Off	8 V (2.0 ±0.08 vpc) (140 ±60 ms)
Reconnect Voltage	9.2 V (2.3 ±0.1 vpc) 8.8V 2.2±0.3V/cell
Short Circuit Protection	200-600 μs

TEMPERATURE SPECIFICATIONS	
Discharge Temperature	-4 to 140 °F (-20 to 60 °C)
Charge Temperature*	-4 to 113 °F (-20 to 45 °C)
Storage Temperature	23 to 95 °F (-5 to 35 °C)
BMS High Temperature Cut-Off	176 °F (80 °C)
Reconnect Temperature	122 °F (50 °C)

\*Refer to charge currents below 32°F (0°C)

MECHANICAL SPECIFICATIONS	
Dimensions (L x W x H)	20.6 x 10.5 x 8.7" 522 x 267 x 220 mm
Weight	76.1 lbs (34.54 kg)
Terminal Type	M8 x 1.25 x 2mm
Terminal Torque	80 - 100 in-lbs (9 - 11 N-m)
Case Material	ABS
Enclosure Protection	IP66
Cell Type - Chemistry	Cylindrical - LiFePO <sub>4</sub>

CHARGE SPECIFICATIONS	
Recommended Charge Current	15 A - 50 A
Maximum Charge Current	100 A
Charge Current 14 to 32 °F (-10 to 0 °C)	≤0.1 C
Charge Current -4 to 14 °F (-20 to -10 °C)	≤0.05 C
Recommended Charge Voltage	14.2 V - 14.6 V
BMS Charge Voltage Cut-Off	15.6 V (3.9 ±0.05 vpc) (1.0 ±0.5 s)
Reconnect Voltage	15.2 V (3.8 ±0.05 vpc)
Balancing Voltage	14.4 V (3.6 ±0.025 vpc)

HEATING ELEMENT SPECIFICATIONS:	
Heating Temperature Range	-4 to 50 °F (-20 to 5 °C)
Heating Time Approximately	1.5 hr @ 15 A

COMPLIANCE SPECIFICATIONS	
Certifications	UN38.3 & CE (battery) UL1642 (cells) (File# MH64523) IEC62133 (cells)
Shipping Classification	UN 3480, CLASS 9

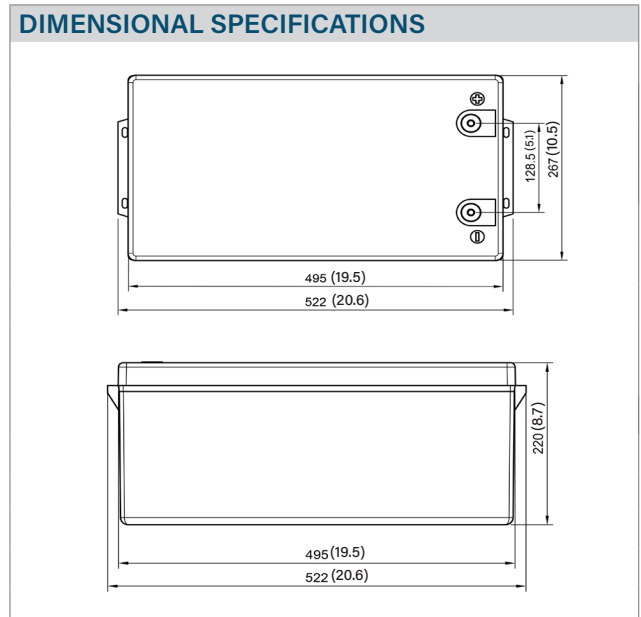



# RB300-LT

Voltage: 12.8V | Capacity: 300 Ah | Energy: 3840 Wh | Group: 8D

LITHIUM IRON PHOSPHATE BATTERY **LiFePO4**

## PERFORMANCE CHARACTERISTICS

DISCHARGE VOLTAGE CHARACTERISTICS at VARIOUS RATES  
25°C (77°F)

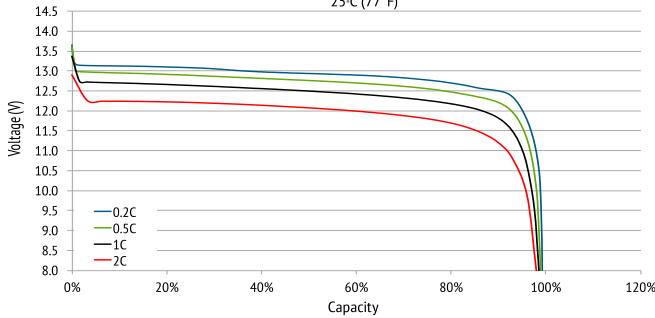

DISCHARGE VOLTAGE CHARACTERISTICS at VARIOUS TEMPERATURES  
DISCHARGE 1C

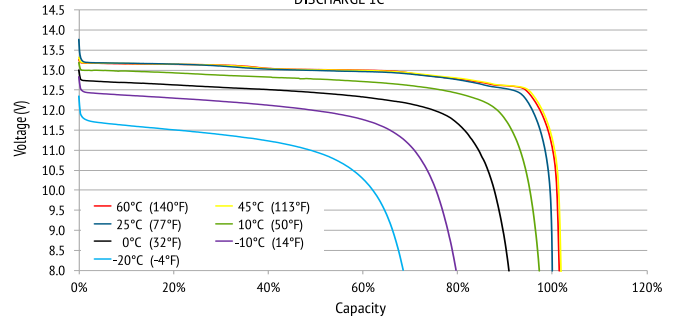

CHARGE VOLTAGE CHARACTERISTICS at VARIOUS TEMPERATURES  
CHARGE 0.2C

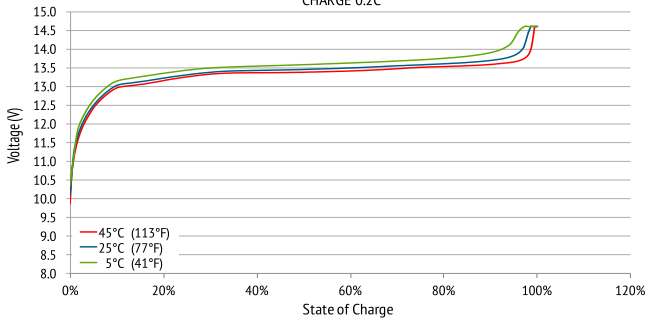

CHARGE VOLTAGE and STATE OF CHARGE (SOC)  
CHARGE 0.2C @ 25°C (77°F)

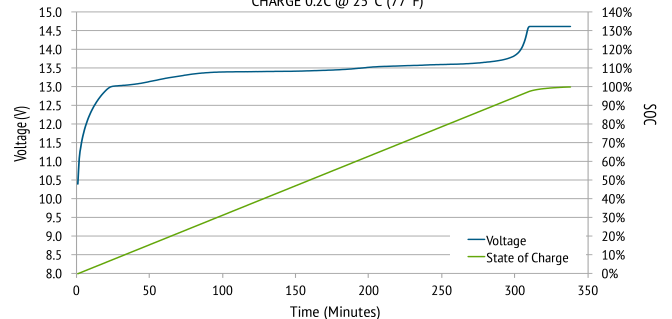

CYCLE LIFE vs. DEPTH OF DISCHARGE (DOD)  
DISCHARGE 0.5C/CHARGE 0.5C @ 25°C (77°F)

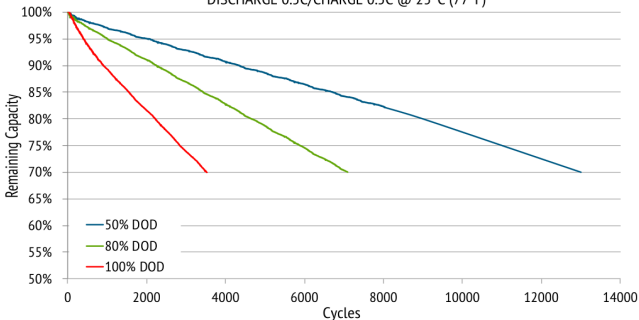

CAPACITY of RELION LiFePO4 vs. LEAD ACID  
at VARIOUS RATES OF DISCHARGE

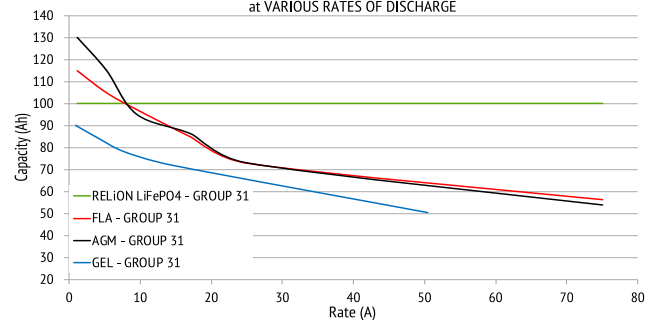

UN38.3

