

# Quick Rack™

Elevated Water Seal Technology™

Installation Manual

Patented Rail-Free Mounting System  
for Composition/Asphalt Shingle Roofs



**Quick Mount PV®**  
RESPECT THE ROOF

# Table of Contents

## Installation Instructions

I.	Quick Rack Components.....	1
II.	Quick Rack Assemblies.....	2
III.	Array Layout.....	4
IV.	Installing Mounts.....	5
V.	Leveling the Mounts.....	7
VI.	Installing the Clamps.....	8
VII.	Installing the Modules.....	10
VIII.	Wire Management.....	11

## Reference

A.	General Requirements.....	Ref-1
B.	Span Tables, Wind Exposure Category Table, and Rafter Attachment Figures.....	Ref-4
C.	Code Compliance.....	Ref-14
D.	Approved Modules List.....	Ref-15
E.	Grounding Information.....	Ref-17
F.	Grounding Path Diagrams.....	Ref-18
G.	System Specifications and Ratings.....	Ref-21
H.	Engineering Drawings.....	Ref-22

# I. Quick Rack Components

Quick Rack rail-free mounting system features QRack® technology. With only 3 main components and an optional skirt, the system works with standard module frames and features Quick Mount PV's high-quality, patented Elevated Water Seal to ensure a long, watertight life on the roof. Components are pre-assembled and ready for installation right out of the box.

1

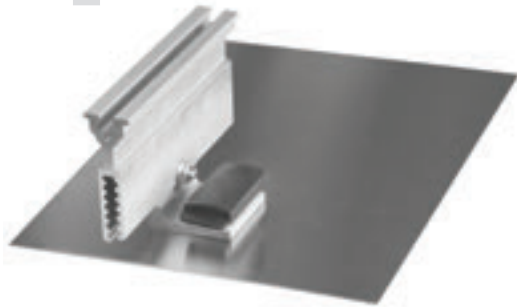

## Base Mount

Featuring Quick Mount PV's patented Elevated Water Seal.

2

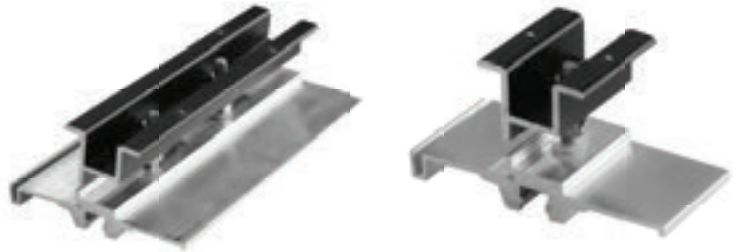

## Panel Clamp

Available in two lengths (2" & 8") for mid-clamping, end-clamping, and module bridging that *work with standard module frames*.

3



## Grounding Lug

Only one IIsco GBL-4DBT grounding lug per system is needed. Lug replaces cap screw in base mount top slider.

4 *Optional*



## Skirt

Snaps right into place for an elegant, streamlined finish.

## II. Quick Rack Assemblies

NOTE: Part quantities are per assembly. For part measurements see pages **Ref-20 - Ref-28** for engineering drawings.

### Base Mount Assembly Parts

- A** Flashing x1
- B** QBlock Slider x1
- C** Top Slider x1
- D** Custom Hex Head Cap Screw x1  
*Torque: 6ft-lbs*
- E** Serrated Flange Hex Nut x1
- F** T-30/Hex Head Structural Screw, 5/16" x1
- G** EPDM/SS Sealing Washer x1
- H** EPDM Screw Cover x1

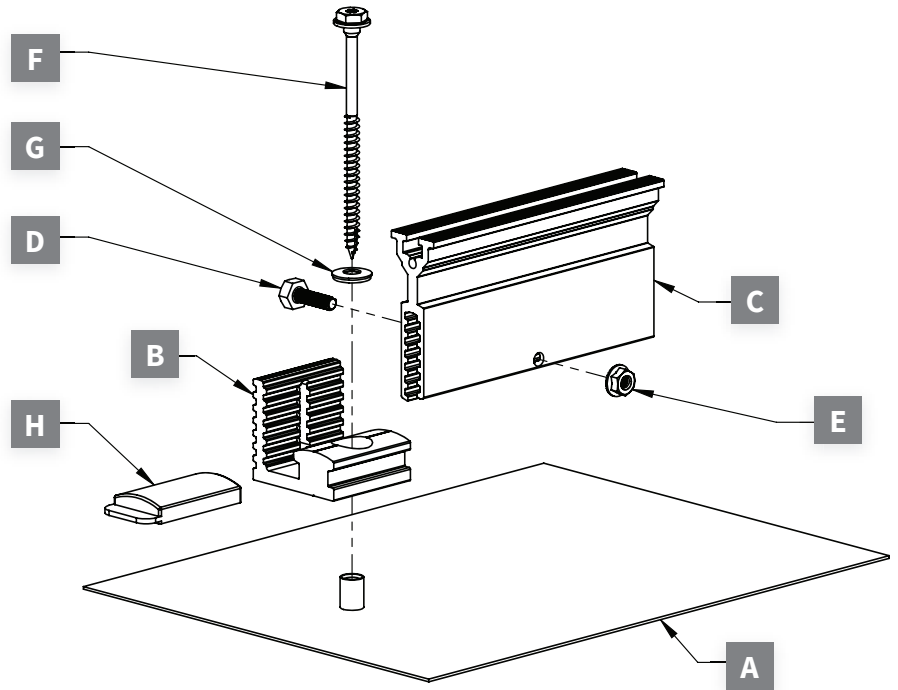

### Skirt Assembly Parts

- A** Skirt x1
- B** Skirt Clip x2
- C** Skirt End Cap, Right x1
- D** Skirt End Cap, Left x1
- E** Sheet Metal Screw x4

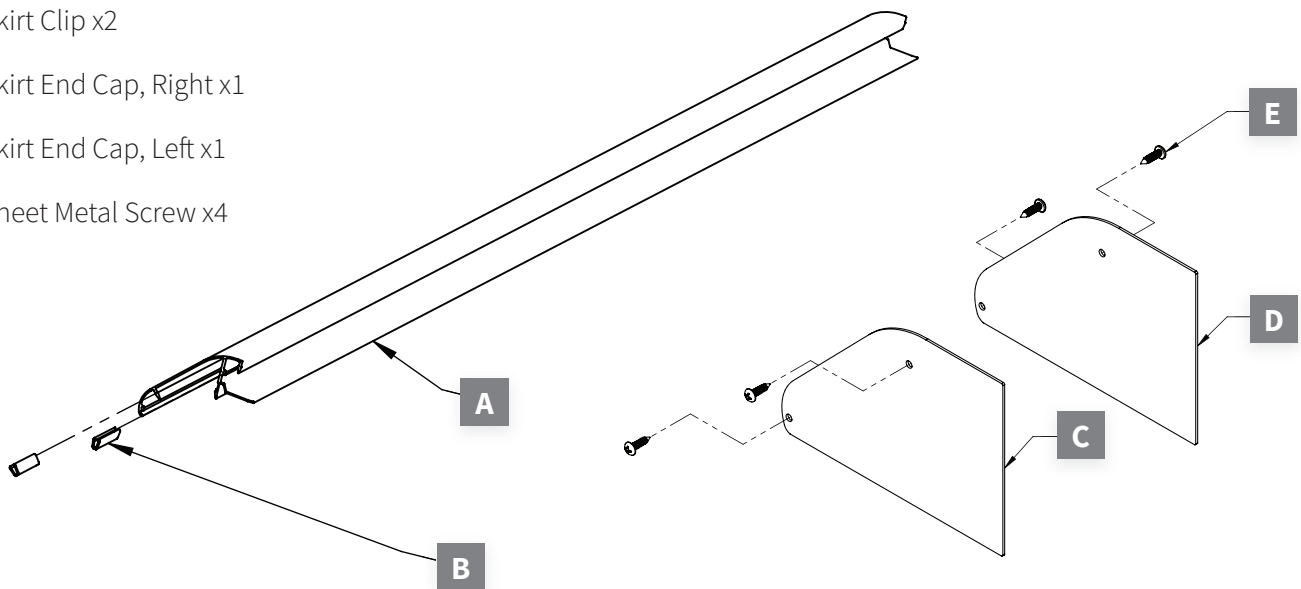

## Panel Clamp Assembly Parts

- A** Clamp Base x1
- B** Panel Clamp (2" or 8") x1
- C** Hex Head Cap Screw x1 (x2 for 8")
- D** Plastic Retainer Ring x1 (2" clamp only)
- E** Hex Nut x1 (x2 for 8")
- F** Serrated Flange Hex Nut x1 (x2 for 8")  
*Torque: 13 ft-lbs*
- G** Clamp Spring (8" clamp only)

2" Panel Clamp Assembly

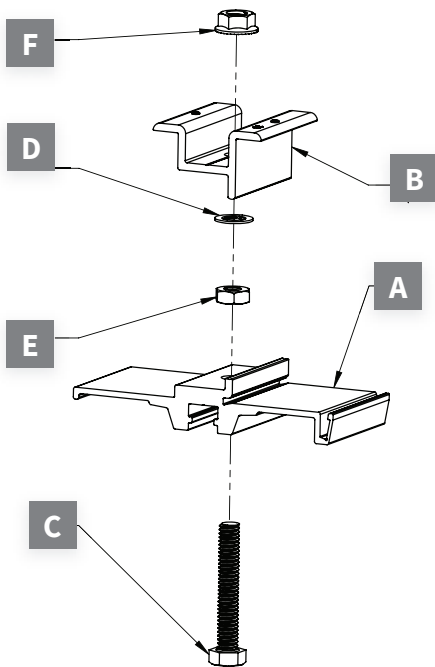

8" Panel Clamp Assembly

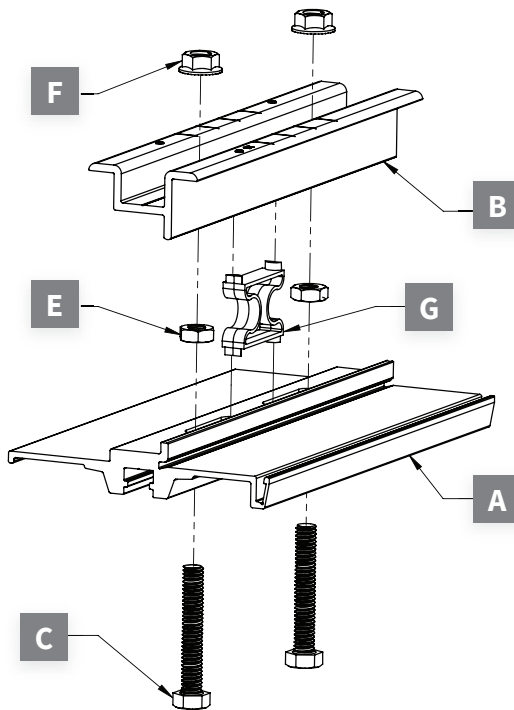

## Grounding Lug Assembly Parts

- A** IlSCO GBL-4DBT Grounding Lug with Set Screw x1
- B** Slotted Stainless Steel Hex Head Cap Screw x1
- C** Star Washer Stainless Steel x1
- D** Serrated Flange Stainless Steel Hex Nut x1

*See page 11 for torque specs*

*All Grounding Lug hardware provided by Quick Mount PV.*

*Minimum of 1/4" clearance required between bare copper wire and aluminum.*

*Recommend use of conductor compound, Deox, between all mount surfaces and hardware, including wireway of grounding lug.*

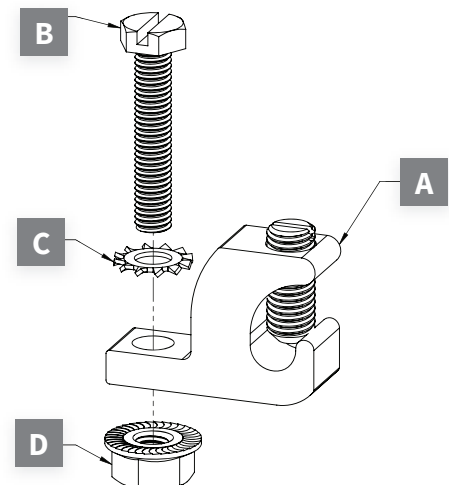

# III. Array Layout

Using your engineered design, locate rafters that will receive a mount. Identify the placement of the first row of mounts being aware that the skirt will overhang the front of the array by 6" and the uppermost flashings will be at least 3 courses down from the ridge.

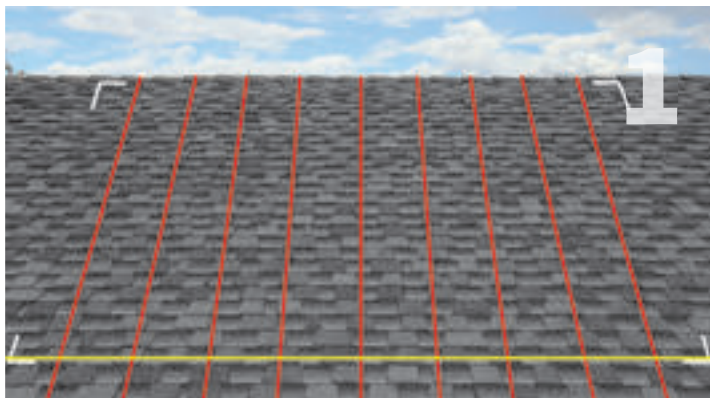

Locate rafters that will receive a mount. Identify the placement of the first row of mounts being aware that the skirt will overhang the front of the array by 6" and the uppermost flashings will be at least 3 courses down from the ridge.



Mark off the locations for the bottom row of mounts. The penetration point for the first row is typically 3" up from the butt of the shingle.

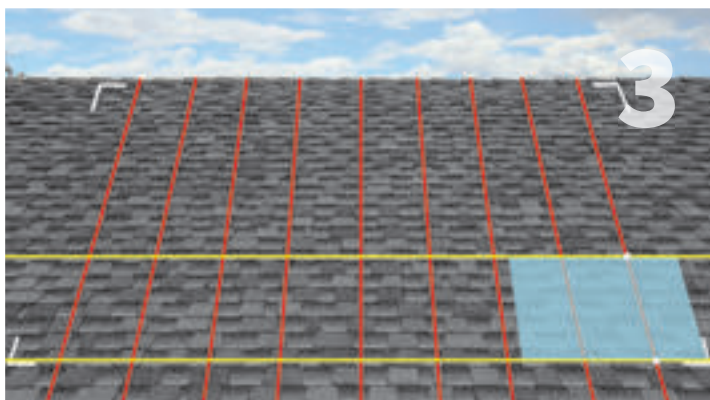

To determine the location for the next row of mounts, measure up from the penetration point the dimension of the module plus 1" for the clamp spacing.

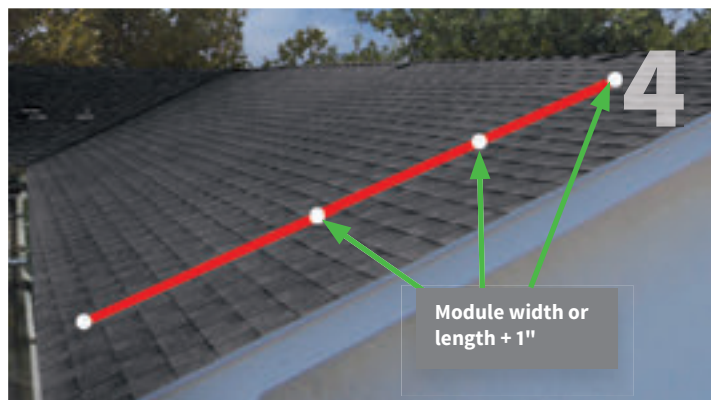

By measuring up in this manner, you are locating the center point of the next mounts' penetration zone. Mark these points off with chalk.

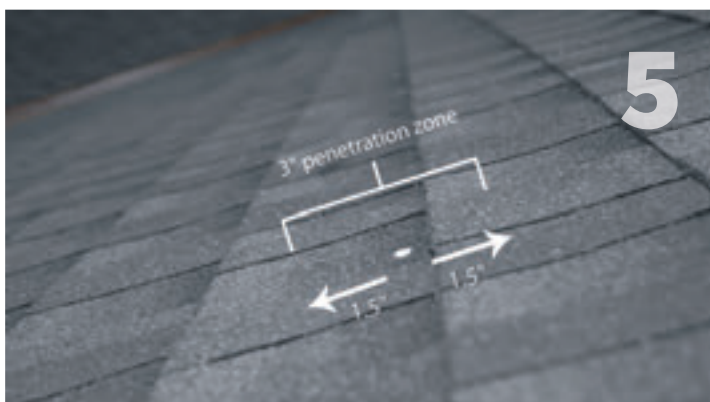

The penetration zone is a 3" range from 1.5" above to 1.5" below the center point. Cutting the shingles is acceptable, but can be avoided by moving the penetration point up or down by 1.5" from the center point.

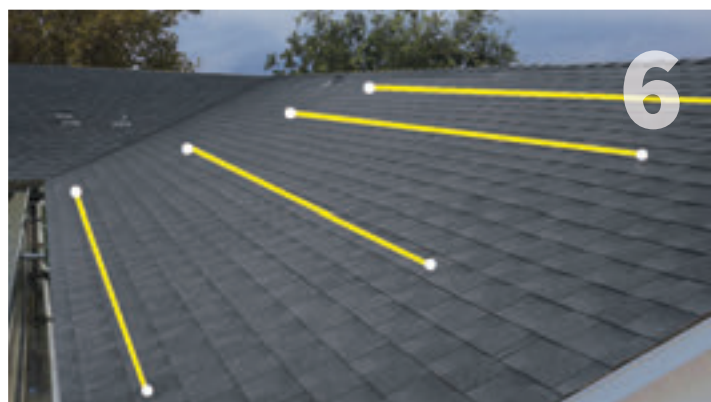

Snap lines at these locations as these measurements translate across the roof for the rest of the mounts.

# IV. Installing the Mounts

**Tool Specs:** Drill, roofing bar, 1/8" x 6" drill bit, T-30 Torx bit or 1/2" socket, appropriate sealant

**Screw Embedment Specs:** 2.5" minimum embedment into rafter

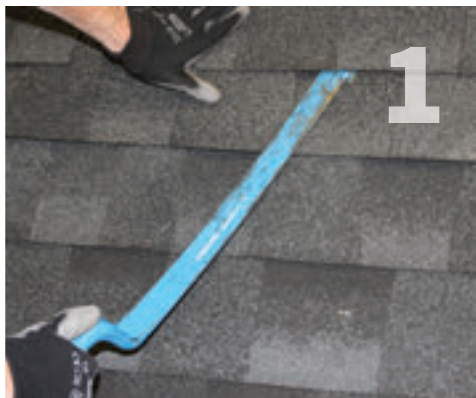

Use roofing bar to break seals between 1st and 2nd, and 2nd and 3rd shingle courses. Be sure to remove all nails to allow correct placement of flashing. See page 6 for proper flashing placement.



Holding the drill square to the rafter, drill 3" deep pilot hole into center of rafter using 1/8" aircraft extension bit.



Fill pilot hole with appropriate sealant.



**Optional:** Apply an upside down U-shaped bead of sealant to the underside of the flashing before insertion. Do not use excessive sealant.



Slide the base mount up underneath the second course of shingles, so that the bottom edge of the flashing does not overhang the butt edge of shingles.



Top slider orientation must alternate so that approximately 50% are pointed left and the remainder are pointed right, except where needed at cantilevers and bridge gaps.



Swivel the base mount to gauge proper torque when driving the lag bolt. Tighten until mounting block stops swiveling easily.

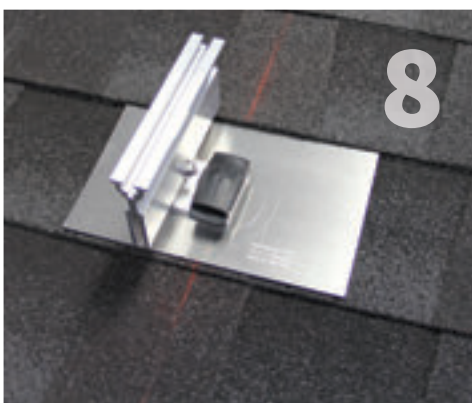

Cap the mounting block with the EPDM rubber cover.



Repeat steps 1-8 to install all mounts

**WARNING:** These products are NOT designed for and should NOT be used to anchor fall protection equipment.

## Additional Tips and Information

- It is not necessary or advisable to use nails or other fasteners to secure the perimeter of the flashing.
- The Base Mount is made to work with standard and high-definition composition/asphalt and wood shingle roofs with 5" to 5-5/8" courses.
- Depending on the season and climate, size and location of seal tabs, and quality of the shingles, the seal tabs that adhere the shingle courses together may not effectively seal the shingles to the flashings. If this is the case, simply add several quarter-sized dabs of manufacturer accepted sealant or asphalt roofing cement, meeting ASTM D 4586 Type II, between the flashing and the shingle above.
- Mounts should not be installed in areas of the roof susceptible to ice damming. Ponding water can travel upward under shingles and reach the bolt penetration.
- Take care not to damage the roofing material while working on the roof. Removing stone granules and deforming the shingles in any way can shorten the lifespan of the roofing. The value of the solar array is directly affected by the condition of the roof it is attached to.

## Proper Flashing Placement

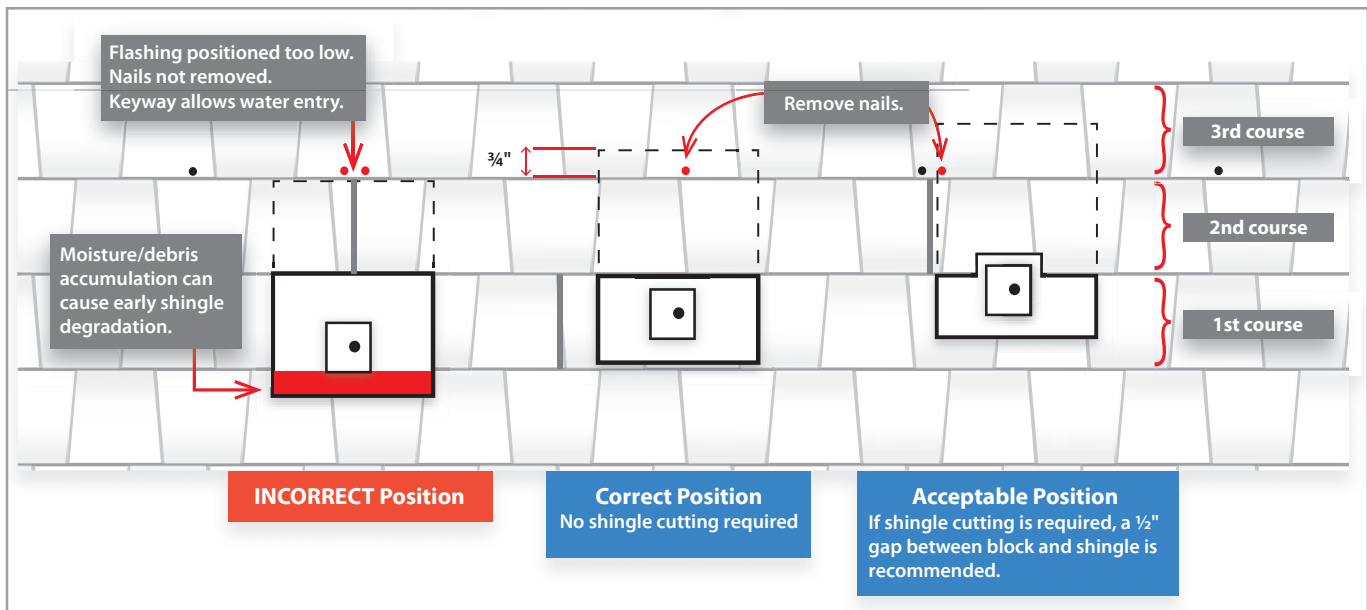



# V. Leveling the Mounts

**Tool Specs:** 1/2" socket and torque wrench

**Torque Specs:** Top slider bolt = 6 ft-lbs

The modules in the Quick Rack system are unified by rigid panel clamps into a single flush surface, so small dips and curves in the roof's surface may not be visually apparent. However, mounts that are close together should be level with each other. To reduce time on the roof, use your own judgment about where a dip is significant enough to require leveling to maintain a smooth looking surface. See page **Ref-2** for alternative Snow Country height requirements.

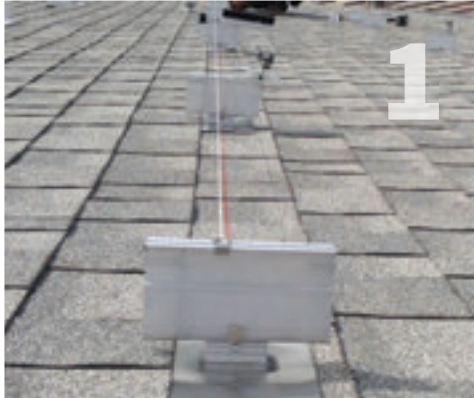

1 Run a string line between the first and last mounts in the first row.



2 The string acts as a guide for aligning the top slider positions of all the mounts in the row. To adjust top slider height, remove machine bolt, separate top slider from QBlock slider and reinsert at proper location. Use torque wrench 1/2" socket to torque all top slider bolts to 6 ft-lbs.



3 To adjust in 1/4" increments move the top slider up or down one notch. To adjust in 1/8" increments rotate the top slider 180 degrees. Repeat for the other mounts until top slider elevations are uniform across the row.

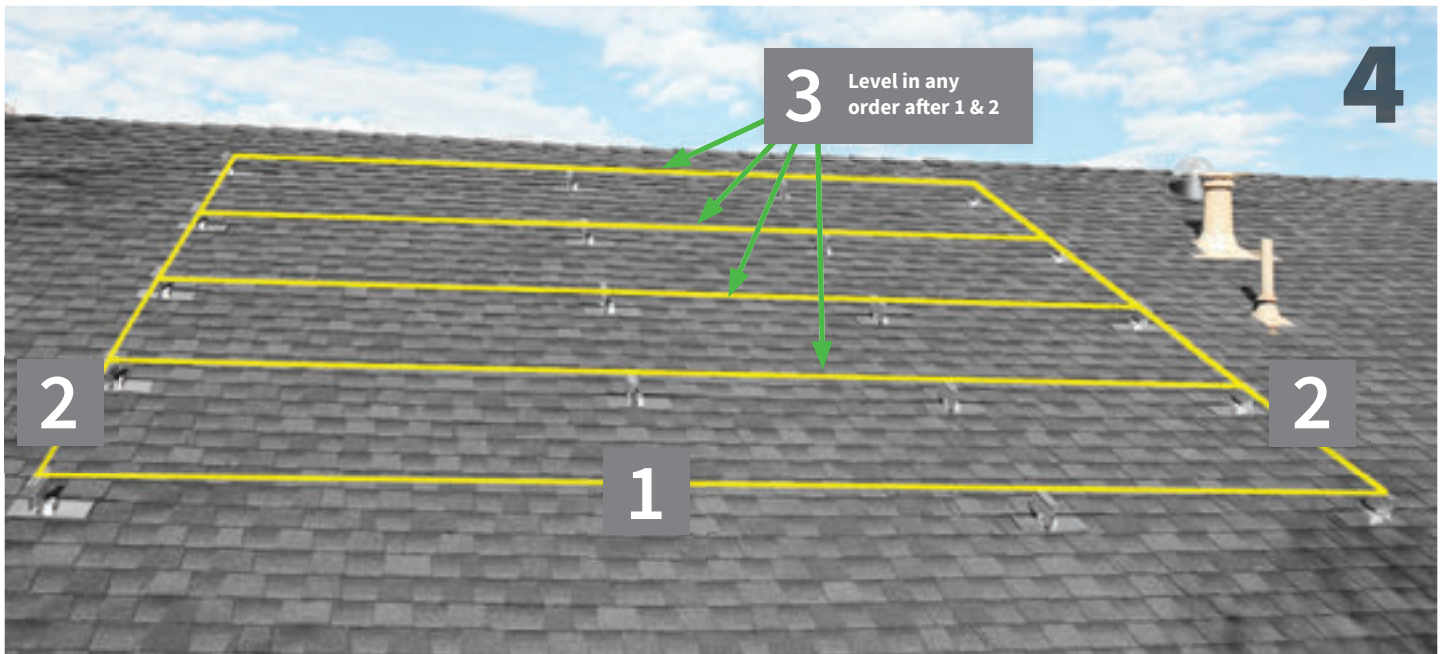

4 After aligning the first row horizontally, follow the same string alignment process vertically on far right and far left columns. Then align each remaining row of the array (in any order).

# VI. Installing the Clamps

**Tool Specs:** 1/2" open end wrench

The modules are connected to the base mounts using 2" panel clamps, which can act as both mid clamps or end clamps, see step 3. The 8" panel clamps are used to bridge modules together. 8" panel clamps can either be floating, or attached to a base mount when the rafters align with a module intersection. Panel clamps include integrated grounding pins. See page **Ref-17** for grounding information.

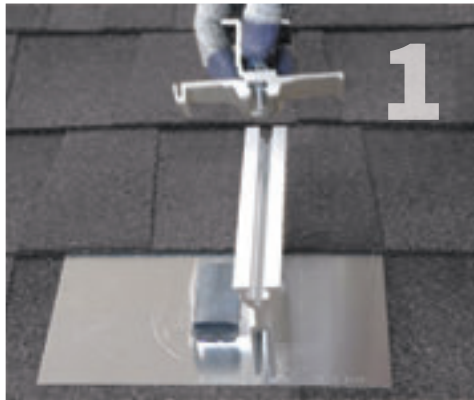

Install all panel clamp assemblies. The bolt head underneath the clamp lines up and slides into the channel on the top of the slider of the base mount.



The spring in the 8" panel clamp allows you to engage either one of the bolts by pressing down the top clamp above the bolt. With the bolt head engaged it slides into the channel on the top of the slider.

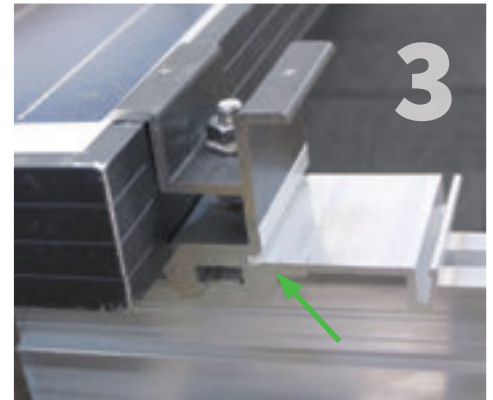

When the 2" or 8" clamp is used as an end clamp in either front or back row, be sure that the long leg on the panel clamp aligns with the short leg on the panel base and is oriented away from the module as shown above.

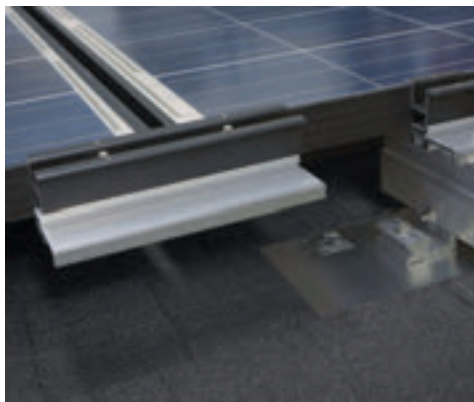

In most cases, 8" clamps are used to structurally bridge together modules with no base mount. However, if a rafter lines up with a base mount, it is also acceptable to use an 8" clamp attached to base mount to bridge modules together.

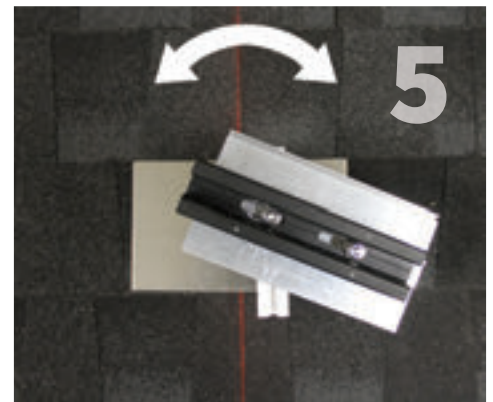
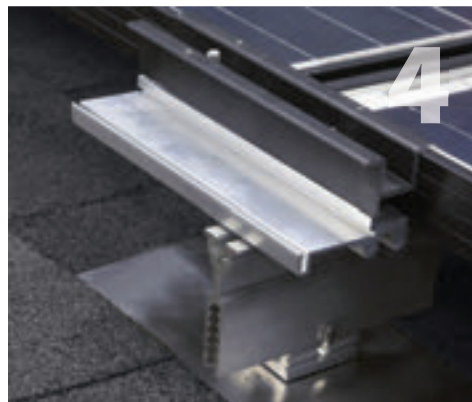

Install 8" clamp in the correct orientation depending on your array design and the location of the module intersection.

# Installing the Clamps & Skirt in the First Row

Only the front row needs to be aligned and locked down in order to assure a straight and secure skirt and array. All other panel clamps in the following rows do not need to be aligned or locked into the base mounts. See page **Ref-2** for alternative Snow Country Installation Requirements.

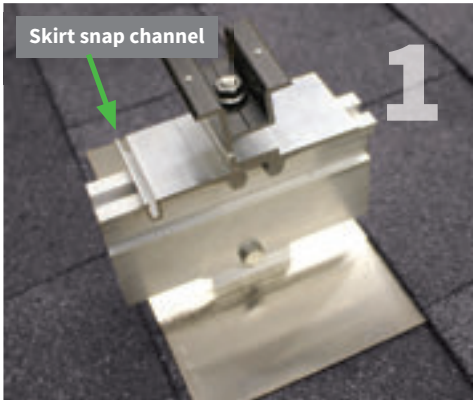

For the first row, clamp must be oriented with skirt snap channel in downslope position.



Use 1/2" open end wrench on mid-clamp assembly nut to tighten clamps to first and last (far left and right) top sliders.



Align first row of clamps using a string line. Tighten all aligned first row clamps using the 1/2" open end wrench.



Match the skirt cantilever to the module cantilever based on your array design.

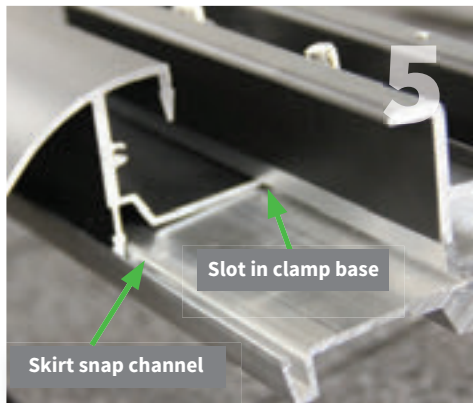

Insert horizontal leg of the skirt into slot in clamp base, then snap the skirt down in skirt snap channel.



Slide 8" bridge clamps onto the skirt segments at the module intersections. Slide the clamp about halfway onto one side of the skirt, and then slide the next segment of the skirt onto the other side of the clamp, finishing by sliding the skirts flush together.

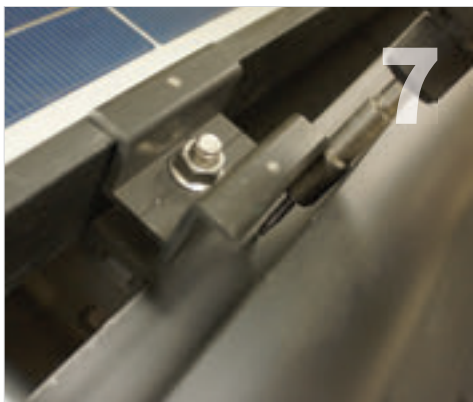

Optional: Supplement skirt attachment by screwing horizontal leg of skirt to horizontal leg of clamp base using a #10 x 5/8" long stainless steel, self drilling, sheet metal screw.



Install remaining skirt sections. Use skirt clips as needed to maintain alignment at skirt junctions.

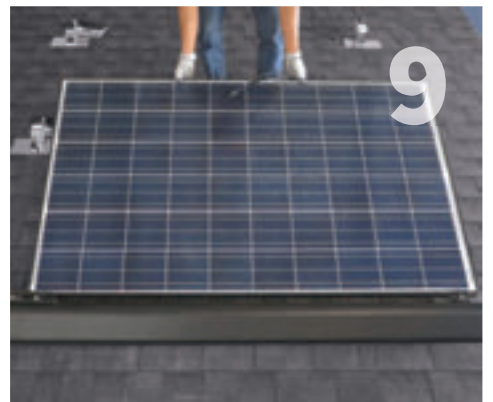

Skirt is optional but acts as an installation aide.

# VII. Installing the Modules

**Tool Specs:** 1/2" socket and torque wrench

**Torque Specs:** Panel Clamp = 13 ft-lbs

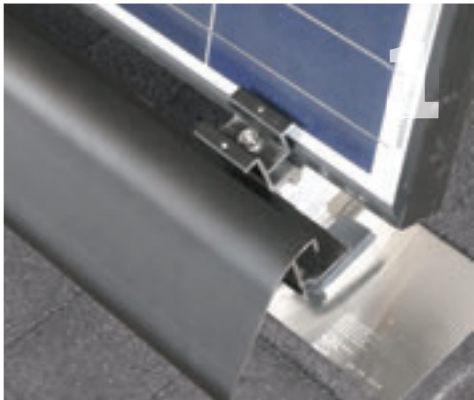

Insert the bottom edge of the module frame into the lower clamps. The top of the module sits on the lower portion of the clamp assembly for the row above.



Where 2, 3, or 4 modules need to be connected, slide the 8" panel clamp over the module frame. The 8" clamp can either be floating or attached to base mount if the rafters line up. See below for proper module gap and clamp placement.

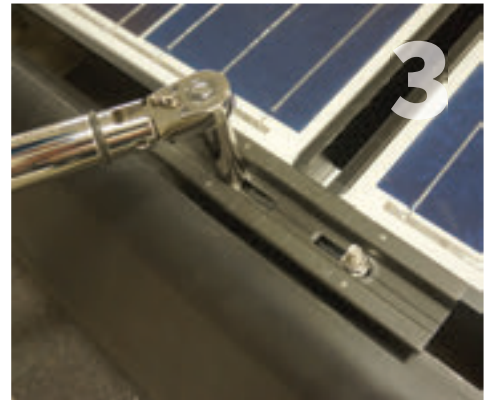

When the first row of modules is in place, tighten down the panel clamps to a torque setting of 13 ft-lbs in the bottom row only using a 1/2" socket on a torque wrench. **DO NOT USE AN IMPACT GUN.**

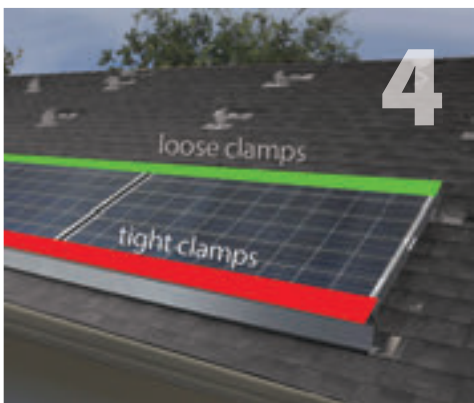

The upper row of clamps should remain loose to accept the next row of modules.



Complete wire management for the first row (see section VIII) and then continue installing modules for all rows, completing wire management for each row as it is installed, then tightening the lower edge of each successive row to 13 ft-lbs using a 1/2" socket on a torque wrench.

## Module Gap and Clamp Placement

Preferred

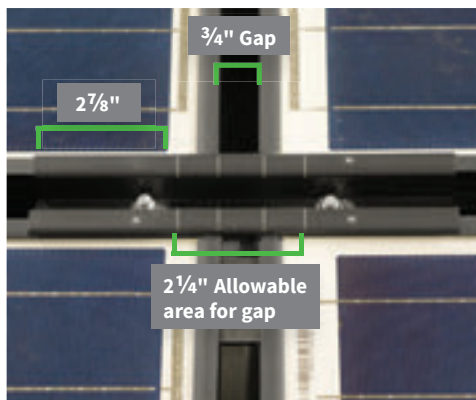

Acceptable

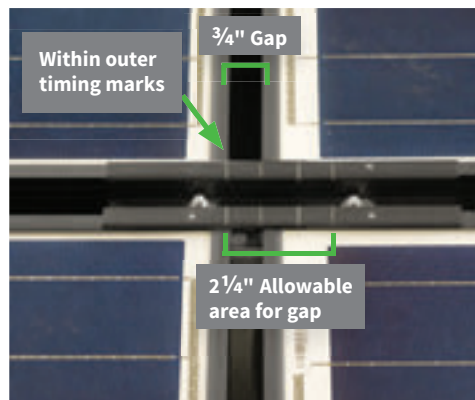

Unacceptable

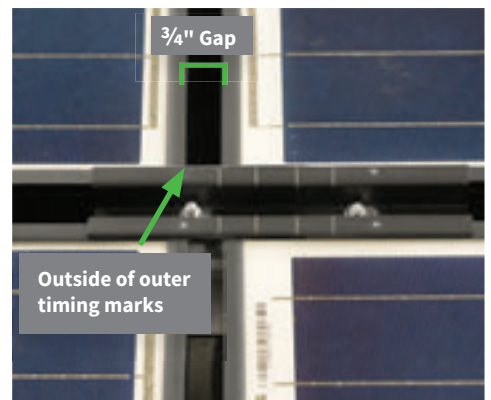

The edge of the module frames must not sit outside the 2 1/4" allowable range indicated by the outer timing marks. The inner set of timing marks show the 3/4" gap centered in the allowable space.

# VIII. Wire Management

**Tool Specs:** Wire clips, flat head screw driver, 5/16" socket and torque wrench

**Torque Specs:** Grounding lug bolt = 35 in-lbs, grounding lug set screw - see below



Complete wire management on a row-by-row basis. With a two man crew, wire management and clamp tightening can be done at the same time.



Before connecting the modules together, be sure to position one of the PV wires out to serve as the homerun connection.



Connect the module leads together and tuck the wires inside the module frame with wire clips on each side of the connectors.



Clip wires to the **inside** of the module frame. Repeat this process across the row of modules. If there is remaining slack in the PV wires, use additional clips to keep wires off the roof surface.

### Wire Management Recommendations

See pages 12-14 for suggested wire configuration, clip placement, and product recommendations.

## Installing the Grounding Lug



See page 3 for proper hardware assembly

The system only requires one IlSCO GBL-4DBT grounding lug. Replace the cap screw in any base mount top slider with grounding lug hardware provided by QMPV, assembled per the diagram on page 3, torque bolt to 35 in-lbs using 5/16" socket on torque wrench.



Secure your wire to the lug by tightening the set screw. A minimum of 1/4" clearance required between bare copper wire and aluminum.

### IlSCO GBL-4DBT Grounding Lug Rated Maximum System Overcurrent Protection (Copper [Cu] Conductor):

- 14 AWG - 15A
- 12AWG - 20A
- 10AWG - 40A
- 8AWG - 90A
- 6AWG - 150A
- 4AWG - 200A

### Grounding Lug Wire Set Screw Torque Specs:

- 4-6 AWG: 35 in-lbs
- 8 AWG: 25 in-lbs
- 10-14 AWG: 20 in-lbs

\*Recommend use of conductor compound, Deox, between all mounting surfaces, including wire way of grounding lug.

## Wire Configuration and Clip Placement

### Suggested Landscape Configuration

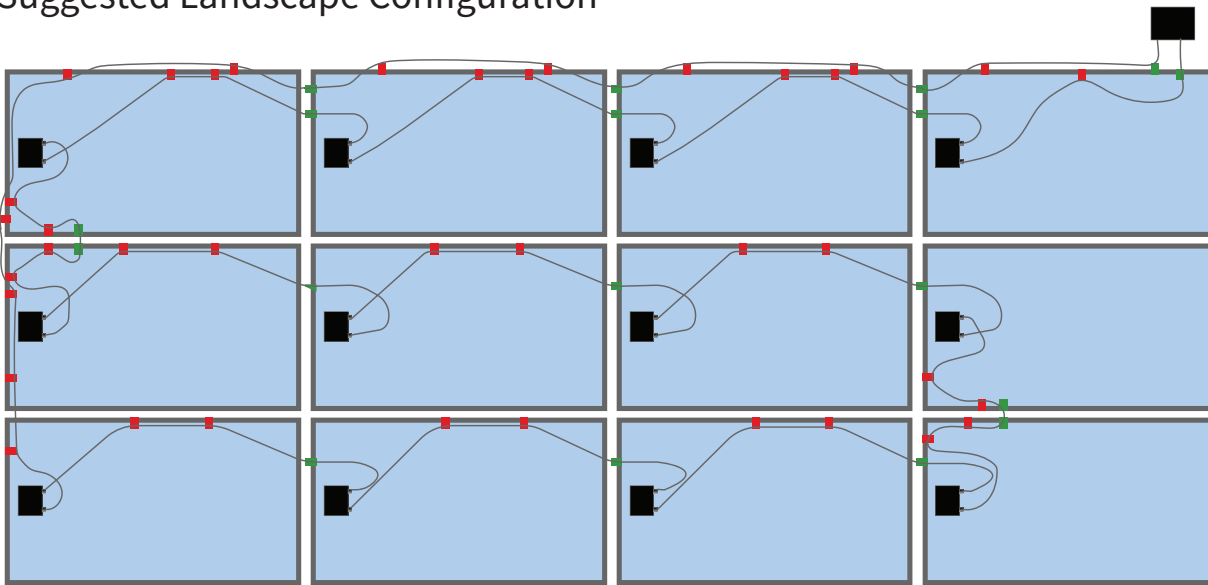

### Suggested Portrait Configuration

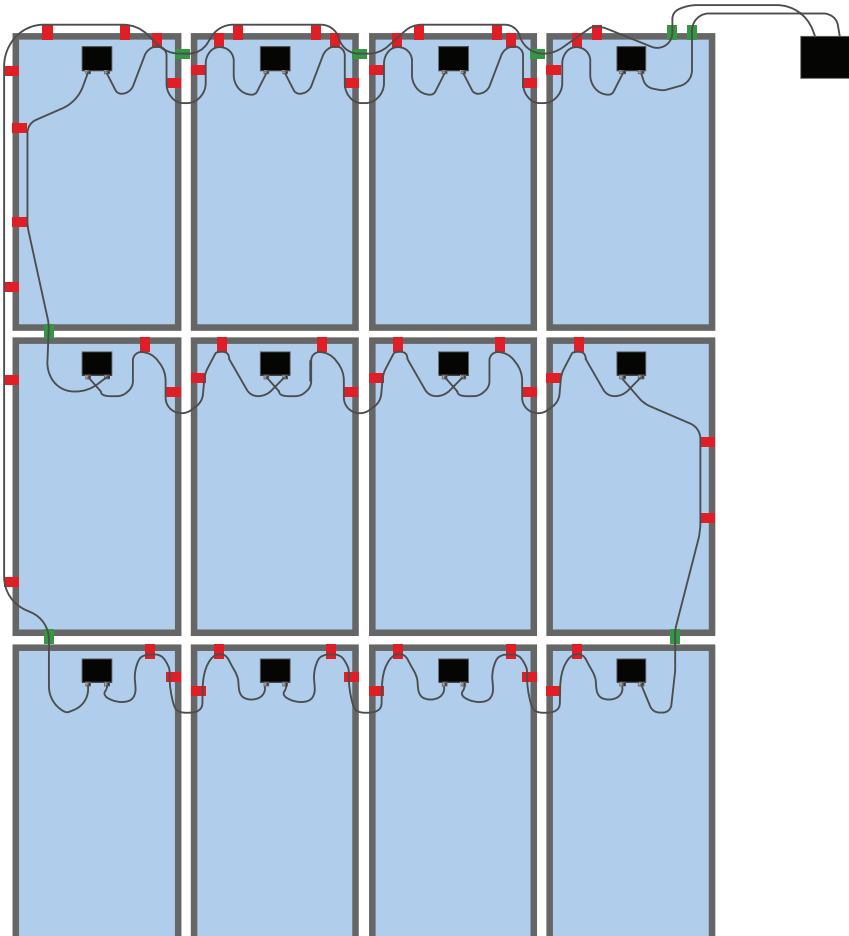

■ Straight or Combination Wire Clips

■ 90° or Combination Wire Clips

■ Junction Box





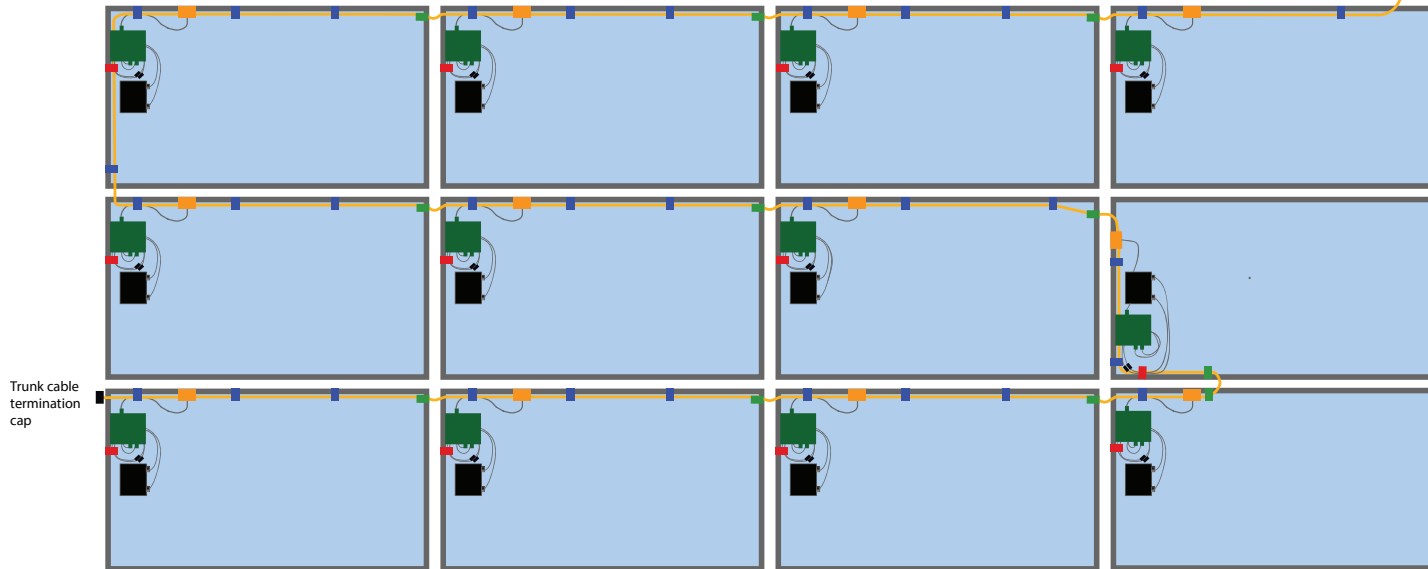

\* To prevent any contact with the roof all wires must be managed by wire clips.

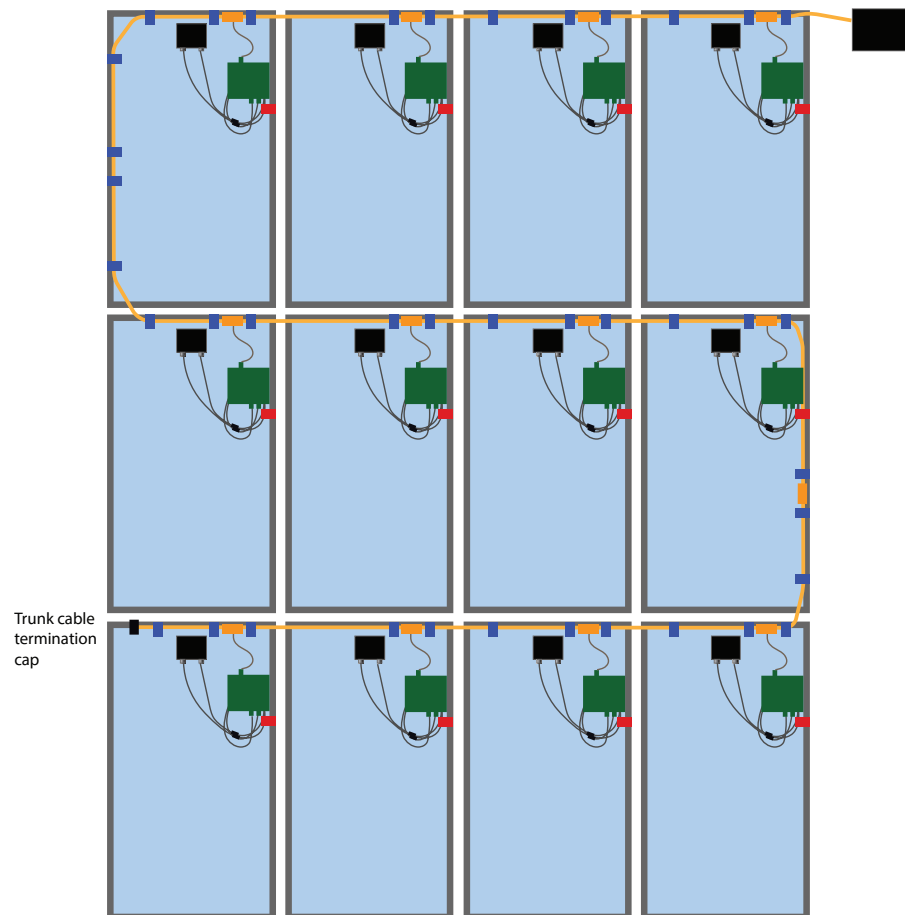
### Suggested Micro-Inverter Landscape Configuration



### Suggested Micro-Inverter Portrait Configuration



-  Trunk Cable Bracket
-  Trunk Cable Clip
-  90° Trunk Cable Clip
-  Micro Inverter
-  Trunk Cable
-  PV Wire Clips
-  Junction Box

Follow module level electronics instructions for mounting.

See next page for Wire Clip Product Recommendations

## Wire Clip Recommendations

Rail-free systems are dependent on wire management clips that hold securely to both the wires and the module frames. After extensive testing, we recommend the following products with this system.

<b>Cable/Wire Type</b>	<b>Straight Clips</b>	<b>90° Clips</b>	<b>Straight and 90° Combo Clips</b>
String Inverter	Nine Fasteners DCS 1307	Heyco® Sunrunner® 90°	Wiley/Burndy® ACC-F90-1
Microinverter	Nine Fasteners NFI-1463	Wiley/Burndy® ACC-FBC w/Unirap™	Wiley/Burndy® ACC-FBC w/Unirap™
Cable Bundles	Wiley/Burndy® ACC-FBC w/Unirap™ HEYClip™ SunRunner® 2-S	Wiley/Burndy® ACC-FBC w/Unirap™	Wiley/Burndy® ACC-FBC w/Unirap™
For SolarWorld modules, use Sunclip™ Universal Wire Management Clip (33mm frame)			



# Reference

## A. General Requirements

The Span Tables, Wind Exposure Category Table, and Rafter Attachment Pattern Figures beginning on page **Ref-4** are subject to the requirements shown in the table footnotes and to the following criteria. See **Quick Rack V1.1-2 Base Mount Code Compliance Report** dated 1-03-2017 by Mar Structural Design if additional information is required.

### Region and Site

- The roof is not in a special topographic region subject to wind speed-up effects, such as near or at the crest of a tall ridge or hill (i.e. ASCE 7 topographic factor of 1.00). Refer to ASCE 7-10 Sec. 26.8 for determining if a roof is in a special wind speed-up zone.
- The building is not a special occupancy structure such as a public school, public safety building or assembly building (i.e. the ASCE 7-10 importance factor is 1.00 for snow and seismic loads, and the building is Risk Category II for wind loads).
- In general, Quick Rack base mount capacity exceeds seismic lateral demands in almost all areas of the United States. The tables list minor limitations in unusual regions where combined high snow and seismic loads may occur.

### Roof Characteristics

- The installation is on wood-framed roofs with composition shingle, wood sawn shingle, built-up roofing, or membrane roofs, underlain by plywood, oriented strand board or solid 1x sheathing.
- The existing roof structure should be generally code-compliant, and should not show signs of decay, fire damage, significant added dead loads, structural modifications (such as removal of web members from carpenter trusses) or any other condition that may weaken its load-carrying capacity. If there is doubt about the suitability of the roof to carry the new PV array, a qualified licensed engineer should be retained to inspect and analyze the existing roof structure.
- The PV array is installed on the roof of an enclosed building with a mean roof height less than or equal to 35 feet. The mean roof height is defined as the average height of the roof eave and the highest point on the roof.
- The roof pitch is between 2:12 (9.5 degrees) and 12:12 (45 degrees).
- Rafters have a minimum nominal width of 2" (1.5" actual width) and have a specific gravity of 0.42 or greater, allowing lumber species groups that range from relatively lightweight, such as Spruce-Pine-Fir, Hem-Fir and Close Grain Redwood, to denser woods such as Douglas Fir and Southern Pine.
- In existing construction, rafters are dry and seasoned. In new construction, rafters are either Kiln-Dried (KD) or Surfaced Dry (S-DRY), or, if Surfaced Green (S-GRN), have an in-field measured moisture content of 19% or less.

### Installation Specifics

- The maximum short edge panel width for PV modules installed in landscape orientation is 40".
- The maximum long edge panel length for PV modules installed in portrait orientation is 66".

## Installation Specifics, cont'd

- Each Quick Rack base mount is fastened to the roof rafter with one 5/16" nominal diameter structural screw, defined as either a 5/16" nominal diameter GRK RSS screw with Climatek coating or a 5/16" nominal diameter QMPV Dual-Drive screw, each pre-drilled with an 1/8" pilot hole to prevent splitting. The structural screw shall be embedded at least 2.5" into the roof rafter. The structural screw shall be torqued to achieve a snug fit of the mount to the flashing (the QBlock Slider should not be able to rotate easily).
- For all PV module orientations, the Quick Rack base mount Top Slider tracks are positioned parallel to roof slope and connect to the module edges that run perpendicular to the slope. Alternate mounts so that approximately 50% of the base mount "elevated seal regions" (toes) point in the nominal west (left cross-slope) direction with the remainder pointing in the opposite direction. Exceptions are allowed at cantilevers and at bridge clamps between modules.
- The PV modules shall be clamped to the Quick Rack track using the provided two-part clamp (clamp base and panel clamp) and a 5/16" stainless steel (grade 18/8) machine bolt, **torqued to no less than 13 ft-lbs and no more than 20 ft-lbs**. For zero and low snow regions, the center of the machine bolt into the top slider shall be installed no more than 1.5" upslope or downslope from the center of the top slider. Machine bolts may be installed in any position along the slots in the 8" clamp.
- Snow country additional requirements must be followed when ground snow load is 21 psf or greater for landscape orientation and 16 psf or greater for portrait orientation. See ***Snow Country Installation Requirements*** below.
- The maximum PV mount and module cantilevers are defined in Figure 4 and enumerated in Tables 1B, 1C, 2B and 2C.
- Per AC-428, the upslope and downslope edge of the PV array shall be no closer than 10" to the eave or ridge of the roof. Per Tables 1B, 1C, 2B and 2C, the sides of the array shall be no closer than 12" to the gable end, rake or hip edges of the roof (and more than 12" where required by the tables to achieve greater cantilever lengths).
- To prevent excessive snow build-up, where the ground snow load exceeds 10 psf, the top edge of the PV array shall be set no farther than 5 feet from the roof ridge, measured perpendicular to the ridge. Note that local fire jurisdictions sometimes require that the top edge of the array be set no closer than a certain distance (often 3 feet) to the ridge.
- If a skirt is installed along the bottom and/or top edge of an array, the gap between bottom of skirt and top of roof surface shall be at least 1/2". Nominal left and right edges of the array shall remain open.
- The dead load of the PV array (sum of the PV modules and Quick Rack base mount hardware) shall not exceed 3.5 psf.
- This code compliance report is limited to base mount structural performance. The modules installed in combination with Quick Rack shall also have UL 1703/2703 rated load capacities appropriate for the site's wind and snow loads.
- In regions subject to freezing, mounts must not be located in roof areas of potential ice dams.
- In regions subject to snow loads, modules are not permitted in roof areas prone to snow drift.

## Snow Country Installation Requirements

- "Snow Country" are regions with the following ground snow loads:
  - 21 psf or greater, for arrays with modules in landscape mode.
  - 16 psf or greater, for arrays with modules in portrait mode.
- See Figure 2B on page **Ref- 9** for restrictions on downslope positions of clamps and maximum heights of mounts, as also described below.

## Snow Country Installation Requirements, cont'd

- Clamp position on top slider( $\pm 1/8$ " installation tolerance):
  - At any bottom row of mounts, clamps shall be installed on top sliders so that the center of the machine bolt into the top slider is 1.5" upslope from the center of the top slider.
  - For subsequent rows of mounts, clamps shall be installed so that the center of the machine bolt into the top slider shall be installed no more than 1.5" upslope or 1.0" downslope from the center of the top slider.
- Height of mounts (measured from bottom of mount to top of top slider):
  - Default factory mount height: 4.0" from bottom of mount to top of top slider.
  - At the bottom row of mounts, full height  $\pm 0.5$ " adjustability is allowed (mount height = 3.5" to 4.5")
  - For subsequent rows of mounts, mount height shall be no higher than 4.0" (default factory height), so that mounts can only be adjusted to be 0.5" shorter (mount height = 3.5" to 4.0").
- Note: These requirements will alter the steps for determining the location of the second row of mounts in the array layout (see page 4).
  - After marking the locations of the first row of mounts in your layout, measure up the rafter from the penetration point the width/length of the module plus 2.5". This is the center point of the penetration zone of the second row of mounts.
  - The snow country penetration zone is 1" downslope from center and 1.5" upslope from center, for a range of 2.5".
  - For the remainder of the rows the penetration zone center point will be module width/length plus 1" upslope from previous row, follow penetration zone range above.

# B. Span Tables, Wind Exposure Category Table, and Attachment Figures

Use the tables and Figures on the following pages to determine mount spacing for your array layout design.

**Table 1A. Quick Rack Base Mount Maximum Spacing, Modules in Landscape Orientation**

Wind Speed ASCE 7-05 (Service Level)		ASCE 7-10 (Strength Level)	Roof Pitch	Ground Snow Load																			
				0 - 20 psf				21 - 30 psf				31 - 40 psf				41 - 50 psf				51 - 60 psf			
				B	C	D	B	C	D	B	C	D	B	C	D	B	C	D	B	C	D		
85 mph	2:12 to 6:12	110 mph	72"	72"	72"	72"	72"	72"	72"	72"	72"	72"	72"	72"	72"	72"	72"	72"	72"				
			48"	48"	48"	48"	48"	48"	48"	48"	48"	48"	48"	48"	48"	48"	48"	48"	48"	48"			
90 mph	2:12 to 6:12	115 mph	72"	72"	72"	72"	72"	72"	72"	72"	72"	72"	72"	72"	72"	72"	72"	72"	72"				
			48"	48"	48"	48"	48"	48"	48"	48"	48"	48"	48"	48"	48"	48"	48"	48"	48"	48"			
95 mph	2:12 to 6:12	120 mph	72"	72"	72"	72"	72"	72"	72"	72"	72"	72"	72"	72"	72"	72"	72"	72"	72"				
			48"	48"	48"	48"	48"	48"	48"	48"	48"	48"	48"	48"	48"	48"	48"	48"	48"	48"			
100 mph	2:12 to 6:12	130 mph	72"	72"	72"	72"	72"	72"	72"	72"	72"	72"	72"	72"	72"	72"	72"	72"	72"				
			48"	48"	48"	48"	48"	48"	48"	48"	48"	48"	48"	48"	48"	48"	48"	48"	48"	48"			
110 mph	2:12 to 6:12	140 mph	72"	72"	72"	72"	72"	72"	72"	72"	72"	72"	72"	72"	72"	72"	72"	72"	72"				
			48"	48"	48"	48"	48"	48"	48"	48"	48"	48"	48"	48"	48"	48"	48"	48"	48"	48"			
120 mph	2:12 to 6:12	150 mph	72"	72"	72"	72"	72"	72"	72"	72"	72"	72"	72"	72"	72"	72"	72"	72"	72"				
			48"	48"	48"	48"	48"	48"	48"	48"	48"	48"	48"	48"	48"	48"	48"	48"	48"	48"			

Table Notes:

1. The Quick Rack base mount maximum allowable spacing listed in this table is the spacing between base mount attachment points in the roof cross-slope direction for modules in landscape orientation.
2. This table is based on an assumed PV module size no larger than 40" x 66".
3. See Figure 4 and Tables 1B and 1C for the maximum mount cantilever (clamp bolt to end-of-module) at the nominal east or west edge of array (cross-slope edge of roof).
4. This table is subject to the conditions stated in the attached Code Compliance Letter, and shown in the attached sketches.
5. This table is based on ASCE 7-10. ASCE 7-05 wind speeds are back-calculated from ASCE 7-10 wind speeds to produce the same wind pressures, rounded to nearest 5 mph.
6. Wind load calculations are based on a Risk Category II building with a mean roof height of 35 feet and  $I_w = 1.0$ .
7. Snow load calculations are based on  $C_e = 1.0$ ,  $I_s = 1.0$ ,  $C_t = 1.2$  and ASCE 7-10 Fig. 7-2a for unobstructed slippery surface (ref. ASCE 7-10 Commentary C7.8)
8. See Table 3 for regions of high wind or snow load where a staggered base mount layout is recommended.
9. The roof pitch range "2:12 to 6:12" corresponds to 9 to 27 degree roof slopes; the roof pitch range "7:12 to 12:12" corresponds to 27.1 to 45 degree roof slopes.
10. Mount capacities are based on ICC AC-13, and are not increased for load duration factor per the restrictions of AC-13. See Appendix 1 for additional information.
11. For locations with an unusual combination of both high seismic and snow loads, see Appendix 2, Table A2.1.

Table 1B. Quick Rack Base Mount Maximum East and West Cantilevers, Modules in **andscape** Orientation with Typical Backspan from Table 1A

Wind Speed (Service Level)	Wind Speed ASCE 7-10 (Strength Level)	Maximum Mount Cantilever with Backspan = Typical Span															
		Typical Span (see Table 1A)			Roof Edge Distance = 36'+			Roof Edge Distance = 24"			Roof Edge Distance = 18"			Roof Edge Distance = 12"			
		Wind Exposure Category	B	C	D	Wind Exposure Category	B	C	D	Wind Exposure Category	B	C	D	Wind Exposure Category	B	C	D
85 mph	110 mph	7-12 to 6:12	72"	72"	72"	24"	24"	24"	24"	24"	24"	21"	21"	21"	18"	18"	18"
90 mph	115 mph	7-12 to 6:12	72"	72"	72"	24"	24"	24"	24"	24"	21"	21"	21"	18"	18"	18"	
95 mph	120 mph	7-12 to 6:12	72"	72"	72"	24"	24"	24"	24"	24"	21"	21"	21"	18"	18"	18"	
100 mph	130 mph	7-12 to 6:12	72"	72"	72"	24"	24"	24"	24"	24"	21"	21"	21"	18"	18"	18"	
110 mph	140 mph	7-12 to 6:12	72"	72"	72"	24"	24"	24"	24"	24"	21"	21"	21"	18"	18"	18"	
120 mph	150 mph	7-12 to 6:12	72"	72"	72"	24"	24"	24"	24"	24"	21"	21"	21"	18"	18"	18"	

- Table Notes:
1. The Quick Rack base mount maximum cantilever listed in this table is the distance from center of clamp bolt (in top slider) to end of module (see Figure 4).
  2. The "backspan" is the first span (i.e. mount spacing) inward from the cantilever (see Figure 4). In this table (Table 1B), backspan matches typical span from Table 1A.
  3. See Table 1C, notes 3 through 9, which also apply to this table.

Table 1C. Quick Rack Base Mount Maximum East and West Cantilevers, Modules in **andscape** Orientation with Atypical 16" or 24" Backspan

Wind Speed (Service Level)	Wind Speed ASCE 7-10 (Strength Level)	Roof Pitch	Maximum Mount Cantilever with Atypical Backspan = 16" or 24"														
			Typical Span (see Table 1A)			Roof Edge Distance = 36'+			Roof Edge Distance = 24"			Roof Edge Distance = 18"			Roof Edge Distance = 12"		
			Wind Exposure Category	B	C	D	Wind Exposure Category	B	C	D	Wind Exposure Category	B	C	D	Wind Exposure Category	B	C
85 mph	110 mph	2:12 to 6:12	72"	72"	72"	24"	24"	24"	24"	24"	24"	24"	24"	24"	24"	24"	24"
90 mph	115 mph	2:12 to 6:12	72"	72"	72"	24"	24"	24"	24"	24"	24"	24"	24"	24"	24"	24"	24"
95 mph	120 mph	2:12 to 6:12	72"	72"	72"	24"	24"	24"	24"	24"	24"	24"	24"	24"	24"	24"	24"
100 mph	130 mph	2:12 to 6:12	72"	72"	72"	24"	24"	24"	24"	24"	24"	24"	24"	24"	24"	24"	24"
110 mph	140 mph	2:12 to 6:12	72"	72"	72"	24"	24"	24"	24"	24"	24"	24"	24"	24"	24"	24"	24"
120 mph	150 mph	2:12 to 6:12	72"	72"	72"	24"	24"	24"	24"	24"	24"	24"	24"	24"	24"	24"	24"

- Table Notes:
1. The Quick Rack base mount maximum cantilever listed in this table is the distance from center of clamp bolt (in top slider) to end of module (see Figure 4).
  2. The "backspan" is the first span (i.e. mount spacing) inward from the cantilever (see Figure 4). In this table (Table 1C), backspan is one rafter spacing (16" or 24").
  3. The "module cantilever" is measured from end of module to closest edge of clamp (see Figure 4). Installer shall verify that module cantilever does not exceed manufacturer recommendations.
  4. The "roof edge distance" is the lateral cross-slope distance from gable end, rake, hip or other roof edge, to end of perimeter module (see Figure 4).
  5. + For buildings with the narrow side wider than 30 feet, increase 36" to 10% of building least plan (footprint) dimension.
  6. This table is based on an assumed PV module size no larger than 40" x 66".
  7. High snow load regions: above 20 psf ground snow load, the maximum mount cantilever shall be the lesser of:  
(i) the maximum cantilever shown in Tables 1B or 1C above, or (ii) half the maximum mount spacing shown in Table 1A (see previous page).
  8. The maximum allowable cantilever shown in these tables ensure that the end mounts & rafters under the array are loaded no more heavily than the interior ones.

Table 2A. Quick Rack Base Mount Maximum Spacing, Modules in **Portrait** Orientation

Wind Speed		Ground Snow Load														
		0 - 15 psf						16 - 30 psf						31 - 45 psf		
		Wind Exposure Category														
ASCE 7-05 (Service Level)	ASCE 7-10 (Strength Level)	Roof Pitch		B	C	D	B	C	D	B	C	D	B	C	D	
85 mph	110 mph	2:12 to 6:12		48"	48"	32"	48"	48"	32"	32"	48"	48"	32"	32"	32"	32"
		7:12 to 12:12		48"	32"	32"	32"	32"	32"	32"	32"	24"	24"	24"	24"	24"
90 mph	115 mph	2:12 to 6:12		48"	48"	32"	48"	48"	32"	32"	48"	48"	32"	32"	32"	32"
		7:12 to 12:12		48"	32"	32"	32"	32"	32"	32"	32"	24"	24"	24"	24"	24"
95 mph	120 mph	2:12 to 6:12		48"	48"	32"	48"	48"	32"	32"	48"	48"	32"	32"	32"	32"
		7:12 to 12:12		32"	32"	24"	32"	32"	32"	32"	32"	24"	24"	24"	24"	24"
100 mph	130 mph	2:12 to 6:12		48"	48"	32"	48"	48"	32"	32"	48"	48"	32"	32"	32"	32"
		7:12 to 12:12		32"	24"	24"	32"	32"	32"	32"	32"	24"	24"	24"	24"	24"
110 mph	140 mph	2:12 to 6:12		32"	32"	24"	32"	32"	32"	32"	32"	32"	32"	32"	32"	24"
		7:12 to 12:12		32"	24"	24"	32"	32"	32"	32"	32"	24"	24"	24"	24"	24"
120 mph	150 mph	2:12 to 6:12		32"	32"	24"	32"	32"	32"	32"	32"	32"	32"	32"	24"	24"
		7:12 to 12:12		32"	24"	16"	32"	32"	32"	32"	32"	16"	16"	24"	24"	24"

Table Notes:

1. The Quick Rack base mount maximum allowable spacing listed in this table is the spacing between base mount attachment points in the roof cross-slope direction for modules in portrait orientation.
2. This table is based on an assumed PV module size no larger than 40" x 66".
3. See Figure 4 and Tables 2B and 2C for the maximum mount cantilever (clamp bolt to end-of-module) at the nominal east or west edge of array (cross-slope edge of roof).
4. This table is subject to the conditions stated in the attached Code Compliance Letter, and shown in the attached sketches.
5. This table is based on ASCE 7-10. ASCE 7-05 wind speeds are back-calculated from ASCE 7-10 wind speeds to produce the same wind pressures, rounded to nearest 5 mph.
6. Wind load calculations are based on a Risk Category II building with a mean roof height of 35 feet and  $I_w = 1.0$ .
7. Snow load calculations are based on  $C_e = 1.0$ ,  $I_s = 1.0$ ,  $C_t = 1.2$  and ASCE 7-10 Fig.7-2a for unobstructed slippery surface (ref. ASCE 7-10 Commentary C7.8)
8. See Table 3 for regions of high wind or snow load where a staggered base mount layout is recommended.
9. The roof pitch range "2:12 to 6:12" corresponds to 9 to 27 degree roof slopes; the roof pitch range "7:12 to 12:12" corresponds to 27.1 to 45 degree roof slopes.
10. Mount capacities are based on ICC AC-13, and are not increased for load duration factor per the restrictions of AC-13. See Appendix 1 for additional information.
11. For locations with an unusual combination of both high seismic and snow loads, see Appendix 2, Table A2.2.

Table 2B. Quick Rack Base Mount Maximum East and West Cantilevers, Modules in **Portrait** Orientation with Typical Backspan from Table 2A

Wind Speed ASCE 7-10 (Service) (Strength)	Typical Span (see Table 2A)				Maximum Mount Cantilever with Backspan = Typical Span												
	Wind Exposure Category				Roof Edge Distance = 36"+				Roof Edge Distance = 24"				Roof Edge Distance = 18"				
	B	C	D	Roof Pitch	Wind Exposure Category	B	C	D	Wind Exposure Category	B	C	D	Wind Exposure Category	B	C	D	
85 mph	48"	48"	32"	2:12 to 6:12	48"	22"	22"	15"	14"	14"	14"	12"	12"	12"	6"	6"	9"
90 mph	48"	48"	32"	2:12 to 6:12	48"	22"	22"	15"	14"	14"	14"	12"	12"	12"	6"	6"	9"
95 mph	48"	48"	32"	2:12 to 6:12	48"	22"	22"	15"	14"	14"	14"	12"	12"	12"	6"	6"	9"
100 mph	48"	48"	32"	2:12 to 6:12	48"	22"	22"	15"	14"	14"	14"	12"	12"	12"	6"	6"	9"
110 mph	48"	48"	32"	2:12 to 6:12	48"	22"	22"	15"	14"	14"	14"	12"	12"	12"	6"	6"	9"
120 mph	48"	48"	32"	2:12 to 6:12	48"	22"	22"	15"	14"	14"	14"	12"	12"	12"	6"	6"	9"

Table Notes:

1. The Quick Rack base mount maximum cantilever listed in this table is the distance from center of clamp bolt (in top slider) to end of module (see Figure 4).
2. The "backspan" is the first span (i.e. mount spacing) inward from the cantilever (see Figure 4). In this table (Table 2B), backspan matches typical span from Table 2A.
3. See Table 2C, notes 3 through 9, which also apply to this table.

Table 2C. Quick Rack Base Mount Maximum East and West Cantilevers, Modules in **Portrait** Orientation with Atypical Backspan = 16" or 24"

Wind Speed ASCE 7-10 (Service) (Strength)	Typical Span (see Table 2A)				Maximum Mount Cantilever with Atypical Backspan = 16" or 24"												
	Wind Exposure Category				Roof Edge Distance = 36"+				Roof Edge Distance = 24"				Roof Edge Distance = 12"				
	B	C	D	Roof Pitch	Wind Exposure Category	B	C	D	Wind Exposure Category	B	C	D	Wind Exposure Category	B	C	D	
85 mph	48"	48"	32"	2:12 to 6:12	48"	24"	24"	17"	16"	16"	16"	11"	11"	15"	15"	13"	9"
90 mph	48"	48"	32"	2:12 to 6:12	48"	24"	24"	17"	16"	16"	16"	11"	11"	15"	15"	13"	9"
95 mph	48"	48"	32"	2:12 to 6:12	48"	24"	24"	17"	16"	16"	16"	11"	11"	15"	15"	13"	9"
100 mph	48"	48"	32"	2:12 to 6:12	48"	24"	24"	17"	16"	16"	16"	11"	11"	15"	15"	13"	9"
110 mph	48"	48"	32"	2:12 to 6:12	48"	24"	24"	17"	16"	16"	16"	11"	11"	15"	15"	13"	9"
120 mph	48"	48"	32"	2:12 to 6:12	48"	24"	24"	17"	16"	16"	16"	11"	11"	15"	15"	13"	9"

Table Notes:

1. The Quick Rack base mount maximum cantilever listed in this table is the distance from center of clamp bolt (in top slider) to end of module (see Figure 4).
2. The "backspan" is the first span (i.e. mount spacing) inward from the cantilever (see Figure 4). In this table (Table 2C), backspan is one rafter spacing (16" or 24").
3. The "module cantilever" is measured from end of module to closest edge of clamp (see Figure 4). Installer shall verify that module cantilever does not exceed manufacturer recommendations.
4. The "roof edge distance" is the lateral cross-slope distance from gable end, rake, hip or other roof edge, to end of perimeter module (see Figure 4).
5. + For buildings with the narrow side wider than 30 feet, increase 36" to 10% of building least plan (footprint) dimension
6. This table is based on an assumed PV module size no larger than 40"x66".
7. High snow load regions: above 15 psf ground snow load, the maximum mount cantilever shall be the lesser of:  
(i) the maximum cantilever shown in Tables 2B or 2C above, or (ii) half the maximum mount spacing shown in Table 2A (see previous page).
8. The maximum allowable cantilever shown in these tables ensure that the end mounts & rafters under the array are loaded no more heavily than the interior ones.

Table 3. Rectangular versus Staggered Anchor Patterns (Mount Layouts)

Ground Snow Load	ASCE 7-10 Wind Speed	Roof Pitch	Wind Exposure Category																				
			B				C				D												
			n = 1	n = 2	n = 3	n = 4	n = 1	n = 2	n = 3	n = 4	n = 1	n = 2	n = 3	n = 4									
0 psf	110 mph	Flat to 6:12	RAP	RAP	RAP	RAP	RAP	RAP	RAP	RAP	RAP	RAP	RAP	RAP	RAP	RAP	RAP	RAP	RAP	RAP	RAP	RAP	
		7:12 to 12:12	RAP	SA	SA*	SA**	RAP	SA	SA*	SA**	RAP	SA	SA*	SA**	RAP	SA	SA*	SA**	RAP	SA	SA*	SA**	
		Flat to 6:12	RAP	RAP	RAP	RAP	RAP	RAP	RAP	RAP	RAP	RAP	RAP	RAP	RAP	RAP	RAP	RAP	RAP	RAP	RAP	RAP	RAP
		7:12 to 12:12	RAP	SA	SA*	SA**	RAP	SA	SA*	SA**	RAP	SA	SA*	SA**	RAP	SA	SA*	SA**	RAP	SA	SA*	SA**	
	130 mph	Flat to 6:12	RAP	RAP	RAP	RAP	RAP	RAP	RAP	RAP	RAP	RAP	RAP	RAP	RAP	RAP	RAP	RAP	RAP	RAP	RAP	RAP	RAP
		7:12 to 12:12	RAP	SA	SA*	SA**	RAP	SA	SA*	SA**	RAP	SA	SA*	SA**	RAP	SA	SA*	SA**	RAP	SA	SA*	SA**	
		Flat to 6:12	RAP	RAP	RAP	RAP	RAP	RAP	RAP	RAP	RAP	RAP	RAP	RAP	RAP	RAP	RAP	RAP	RAP	RAP	RAP	RAP	RAP
		7:12 to 12:12	RAP	SA	SA*	SA**	RAP	SA	SA*	SA**	RAP	SA	SA*	SA**	RAP	SA	SA*	SA**	RAP	SA	SA*	SA**	
	140 mph	Flat to 6:12	RAP	RAP	RAP	RAP	RAP	RAP	RAP	RAP	RAP	RAP	RAP	RAP	RAP	RAP	RAP	RAP	RAP	RAP	RAP	RAP	RAP
		7:12 to 12:12	RAP	SA	SA*	SA**	RAP	SA	SA*	SA**	RAP	SA	SA*	SA**	RAP	SA	SA*	SA**	RAP	SA	SA*	SA**	
		Flat to 6:12	RAP	RAP	RAP	RAP	RAP	RAP	RAP	RAP	RAP	RAP	RAP	RAP	RAP	RAP	RAP	RAP	RAP	RAP	RAP	RAP	RAP
		7:12 to 12:12	RAP	SA	SA*	SA**	RAP	SA	SA*	SA**	RAP	SA	SA*	SA**	RAP	SA	SA*	SA**	RAP	SA	SA*	SA**	
150 mph	Flat to 6:12	RAP	RAP	RAP	RAP	RAP	RAP	RAP	RAP	RAP	RAP	RAP	RAP	RAP	RAP	RAP	RAP	RAP	RAP	RAP	RAP	RAP	
	7:12 to 12:12	RAP	SA	SA*	SA**	RAP	SA	SA*	SA**	RAP	SA	SA*	SA**	RAP	SA	SA*	SA**	RAP	SA	SA*	SA**		
	Flat to 6:12	RAP	RAP	RAP	RAP	RAP	RAP	RAP	RAP	RAP	RAP	RAP	RAP	RAP	RAP	RAP	RAP	RAP	RAP	RAP	RAP	RAP	
	7:12 to 12:12	RAP	SA	SA*	SA**	RAP	SA	SA*	SA**	RAP	SA	SA*	SA**	RAP	SA	SA*	SA**	RAP	SA	SA*	SA**		
110 mph	Flat to 6:12	RAP	RAP	RAP	RAP	RAP	RAP	RAP	RAP	RAP	RAP	RAP	RAP	RAP	RAP	RAP	RAP	RAP	RAP	RAP	RAP	RAP	
	7:12 to 12:12	RAP	SA	SA*	SA**	RAP	SA	SA*	SA**	RAP	SA	SA*	SA**	RAP	SA	SA*	SA**	RAP	SA	SA*	SA**		
	Flat to 6:12	RAP	RAP	RAP	RAP	RAP	RAP	RAP	RAP	RAP	RAP	RAP	RAP	RAP	RAP	RAP	RAP	RAP	RAP	RAP	RAP	RAP	
	7:12 to 12:12	RAP	SA	SA*	SA**	RAP	SA	SA*	SA**	RAP	SA	SA*	SA**	RAP	SA	SA*	SA**	RAP	SA	SA*	SA**		
115 mph	Flat to 6:12	RAP	RAP	RAP	RAP	RAP	RAP	RAP	RAP	RAP	RAP	RAP	RAP	RAP	RAP	RAP	RAP	RAP	RAP	RAP	RAP	RAP	
	7:12 to 12:12	RAP	SA	SA*	SA**	RAP	SA	SA*	SA**	RAP	SA	SA*	SA**	RAP	SA	SA*	SA**	RAP	SA	SA*	SA**		
	Flat to 6:12	RAP	RAP	RAP	RAP	RAP	RAP	RAP	RAP	RAP	RAP	RAP	RAP	RAP	RAP	RAP	RAP	RAP	RAP	RAP	RAP	RAP	
	7:12 to 12:12	RAP	SA	SA*	SA**	RAP	SA	SA*	SA**	RAP	SA	SA*	SA**	RAP	SA	SA*	SA**	RAP	SA	SA*	SA**		
130 mph	Flat to 6:12	RAP	RAP	RAP	RAP	RAP	RAP	RAP	RAP	RAP	RAP	RAP	RAP	RAP	RAP	RAP	RAP	RAP	RAP	RAP	RAP	RAP	
	7:12 to 12:12	RAP	SA	SA*	SA**	RAP	SA	SA*	SA**	RAP	SA	SA*	SA**	RAP	SA	SA*	SA**	RAP	SA	SA*	SA**		
	Flat to 6:12	RAP	RAP	RAP	RAP	RAP	RAP	RAP	RAP	RAP	RAP	RAP	RAP	RAP	RAP	RAP	RAP	RAP	RAP	RAP	RAP	RAP	
	7:12 to 12:12	RAP	SA	SA*	SA**	RAP	SA	SA*	SA**	RAP	SA	SA*	SA**	RAP	SA	SA*	SA**	RAP	SA	SA*	SA**		
140 mph	Flat to 6:12	RAP	RAP	RAP	RAP	RAP	RAP	RAP	RAP	RAP	RAP	RAP	RAP	RAP	RAP	RAP	RAP	RAP	RAP	RAP	RAP	RAP	
	7:12 to 12:12	RAP	SA	SA*	SA**	RAP	SA	SA*	SA**	RAP	SA	SA*	SA**	RAP	SA	SA*	SA**	RAP	SA	SA*	SA**		
	Flat to 6:12	RAP	RAP	RAP	RAP	RAP	RAP	RAP	RAP	RAP	RAP	RAP	RAP	RAP	RAP	RAP	RAP	RAP	RAP	RAP	RAP	RAP	
	7:12 to 12:12	RAP	SA	SA*	SA**	RAP	SA	SA*	SA**	RAP	SA	SA*	SA**	RAP	SA	SA*	SA**	RAP	SA	SA*	SA**		
150 mph	Flat to 6:12	RAP	RAP	RAP	RAP	RAP	RAP	RAP	RAP	RAP	RAP	RAP	RAP	RAP	RAP	RAP	RAP	RAP	RAP	RAP	RAP	RAP	
	7:12 to 12:12	RAP	SA	SA*	SA**	RAP	SA	SA*	SA**	RAP	SA	SA*	SA**	RAP	SA	SA*	SA**	RAP	SA	SA*	SA**		
	Flat to 6:12	RAP	RAP	RAP	RAP	RAP	RAP	RAP	RAP	RAP	RAP	RAP	RAP	RAP	RAP	RAP	RAP	RAP	RAP	RAP	RAP	RAP	
	7:12 to 12:12	RAP	SA	SA*	SA**	RAP	SA	SA*	SA**	RAP	SA	SA*	SA**	RAP	SA	SA*	SA**	RAP	SA	SA*	SA**		
> 10 psf	Flat to 6:12	RAP	RAP	RAP	RAP	RAP	RAP	RAP	RAP	RAP	RAP	RAP	RAP	RAP	RAP	RAP	RAP	RAP	RAP	RAP	RAP	RAP	
	7:12 to 12:12	RAP	SA	SA*	SA**	RAP	SA	SA*	SA**	RAP	SA	SA*	SA**	RAP	SA	SA*	SA**	RAP	SA	SA*	SA**		
	Flat to 6:12	RAP	RAP	RAP	RAP	RAP	RAP	RAP	RAP	RAP	RAP	RAP	RAP	RAP	RAP	RAP	RAP	RAP	RAP	RAP	RAP	RAP	
	7:12 to 12:12	RAP	SA	SA*	SA**	RAP	SA	SA*	SA**	RAP	SA	SA*	SA**	RAP	SA	SA*	SA**	RAP	SA	SA*	SA**		

Table Notes:

RAP = Rectangular Anchor Pattern. If the installer verifies the existing roof is code compliant without the array, it is likely to have sufficient strength to support a PV array without staggering base mounts.

SA = Stagger Anchors. Alternatively, Structurally Assess and Strengthen as Appropriate. See Figures 7 - 10 for acceptable staggered base mount layouts.

\* The staggered pattern shown in Figure 8 is **NOT** acceptable. Instead, reduce the base mount spacing and use the staggered pattern shown in Figure 9.

\*\* The staggered pattern shown in Figure 7 is **NOT** acceptable. Instead, reduce the base mount spacing and use the staggered pattern shown in Figure 9.

1. This table provides general guidelines for when a base mount layout that is anchored to every second, third or fourth rafter is likely to be acceptable when installed in a **rectangular** pattern, and when a **staggered** base mount layout (or alternatively, a structural engineering assessment) is required instead.

2. The installer is responsible for verifying that the existing roof can support typical code-required roof loads by:

(a) checking existing roof rafter spans against the roof rafter span tables of the 2015 International Building Code (Table 2308.10.3.0), the 2015 International Residential Code (Table R805.2.1(l)), or similar superseding state code (available at: <https://law.resource.org/pub/us/code/ibc/ibc.html>); if lumber grade stamps are not visible, some engineers consider it reasonable to assume Douglas Fir No. 2 in states west of the Rocky Mountains (CA, OR, WA, NV, ID) and Spruce-Pine-Fir No. 2 in the remainder of the continental United States, and

(b) verifying the existing roof structure is free of damage, decay or unusual sagging. Refer to Figure 1 of Toolkit Document #5 (Structural Criteria for Residential Rooftop Solar Energy Installations) on page 53 of the *2015 California Solar Permitting Guidebook*.

3. Concentrated loads on a rafter from Quick Rack base mounts are assumed to be partially shared with adjacent rafters as described in Section 2.F of the *Structural Technical Appendix for Residential Rooftop Solar Installations* (available at: [http://www.opr.ca.gov/docs/Solar\\_Structural\\_Technical\\_Appendix.pdf](http://www.opr.ca.gov/docs/Solar_Structural_Technical_Appendix.pdf)).

4. The roof pitch range "2:12 to 6:12" corresponds to 9 to 27 degree roof slopes; the roof pitch range "7:12 to 12:12" corresponds to 27.1 to 45 degree roof slopes.

5. This table does not apply to wood trusses. Consult with a structural engineer or the original truss manufacturer to verify that existing trusses can carry the specific loading pattern of a new solar array.



# Clamp and Top Slider Allowable Positions Figure 2B

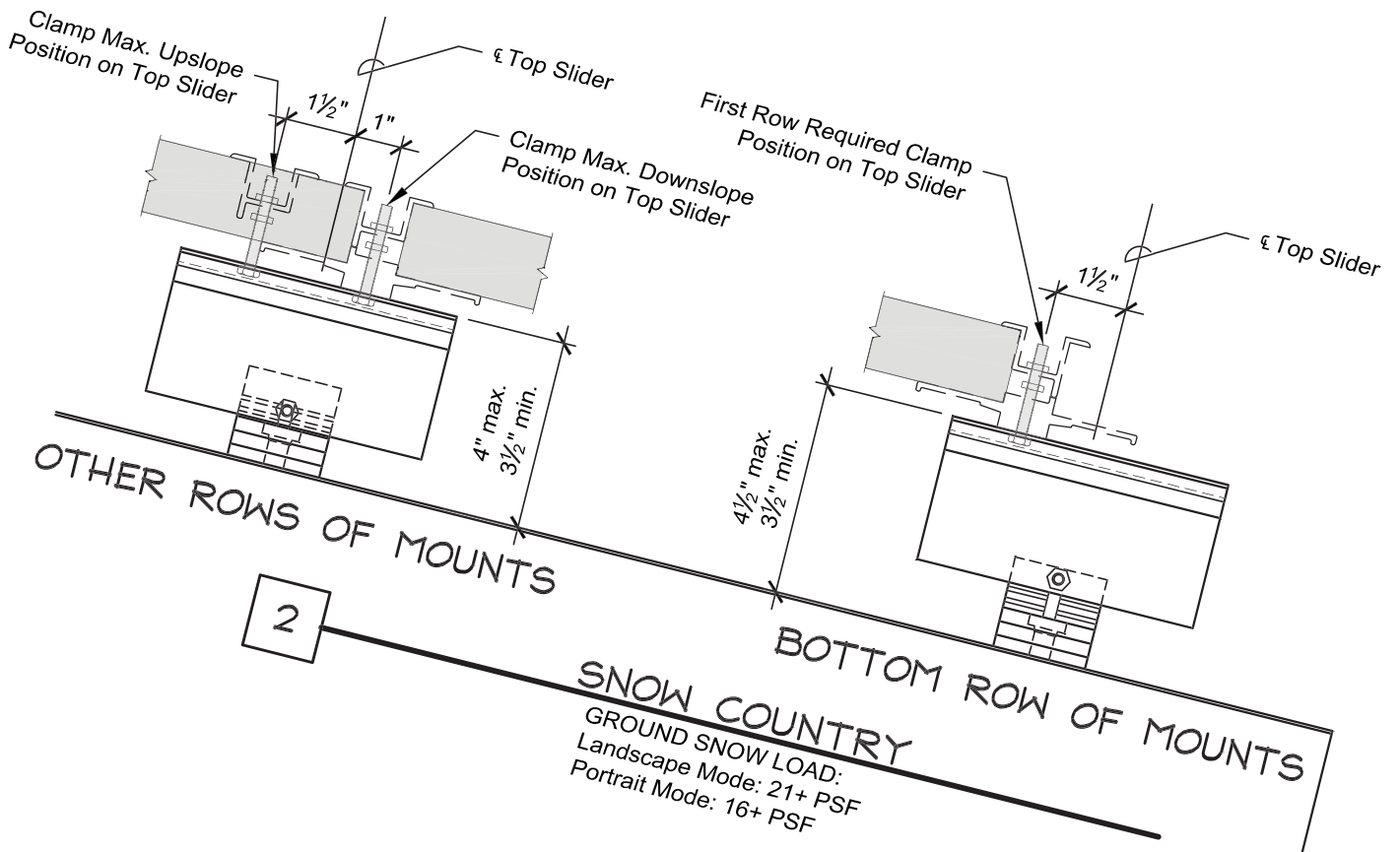
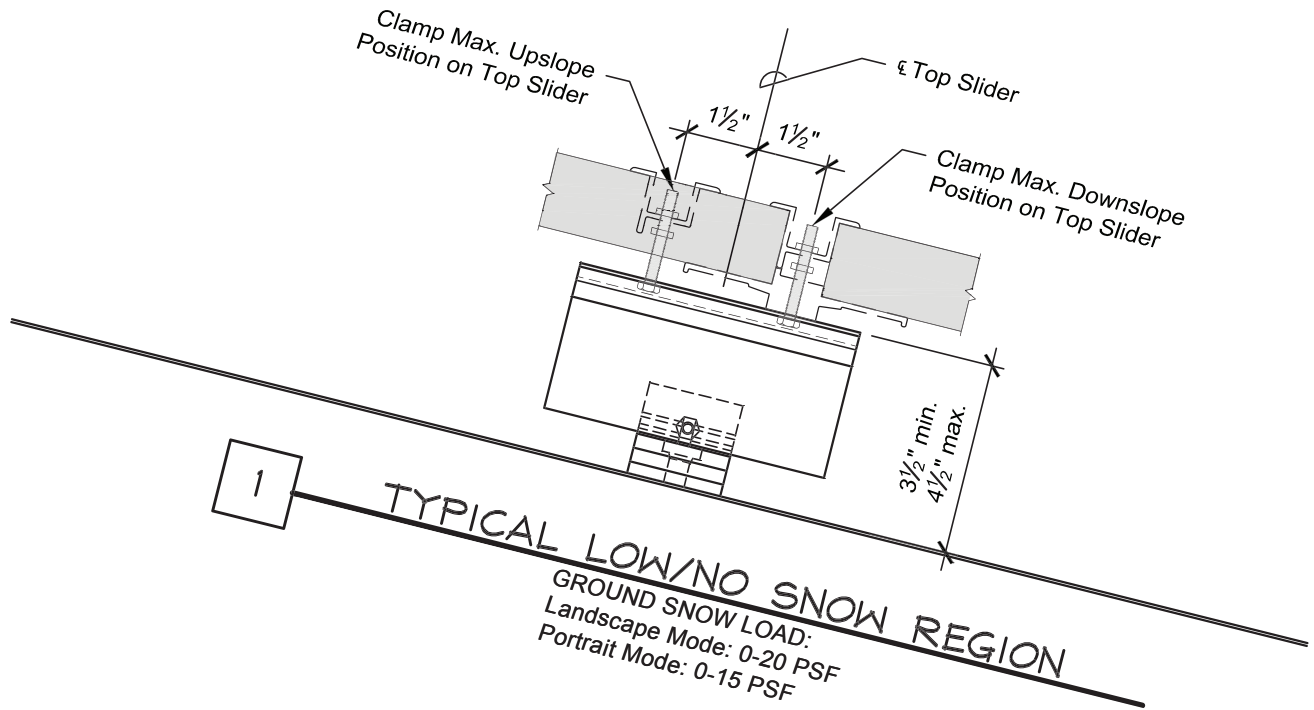

# Cantilever Reference Figure 4

This figure references tables on pages **Ref-3 - Ref-7**.

Reference

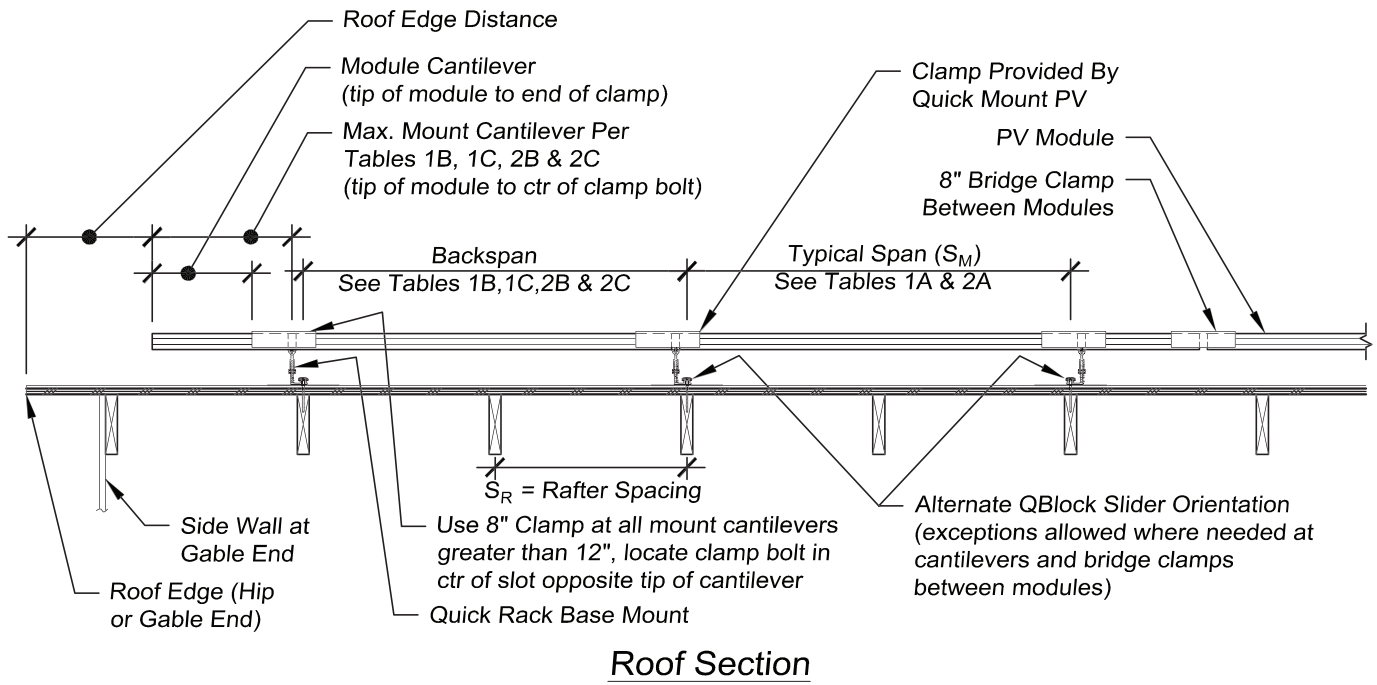

# Rafter Attachment Pattern Figure 7

$S_M$  = Base Mount Spacing  
 $S_R$  = Rafter Spacing  
 $n$  = Number Of Rafter Spaces  
 $= S_M / S_R$

## $n = 4$ Rafter Attachment Pattern

For  $S_R = 16''$  o.c.

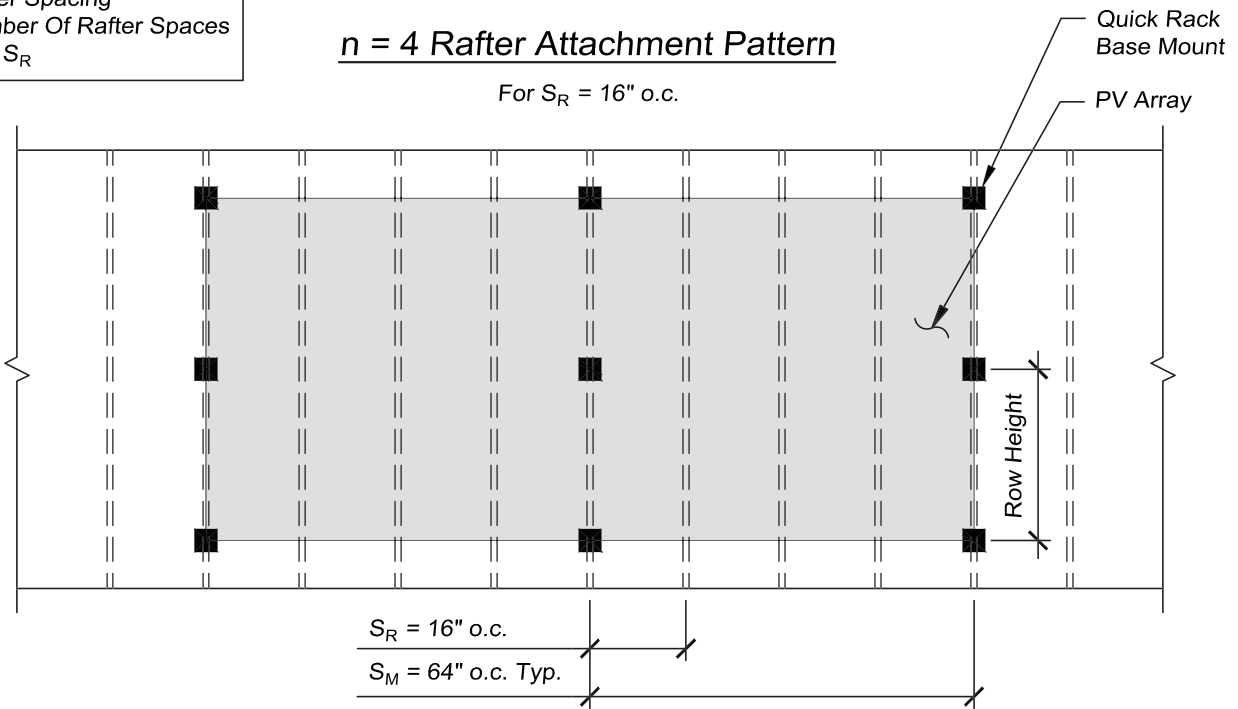

## Staggered Rafter Attachment Pattern To Attain $n = 2$ Equivalence

For  $S_R = 16''$  o.c.

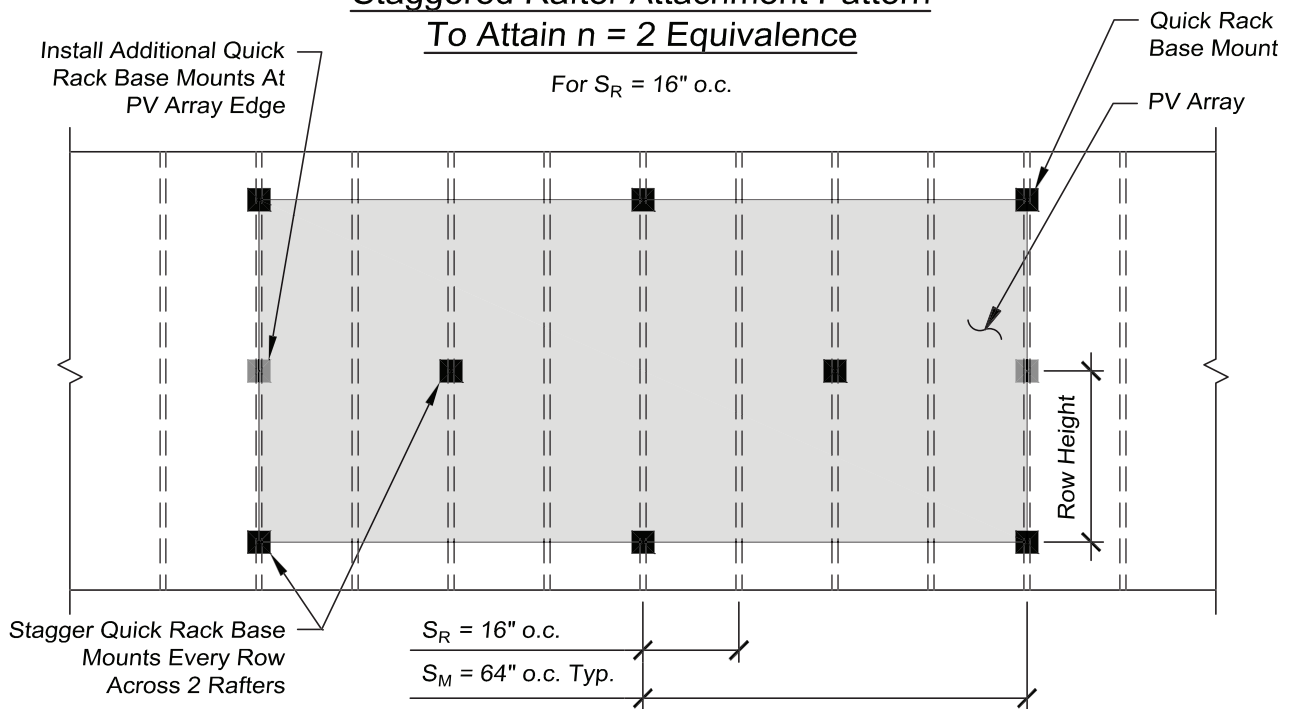

**Note:** This staggered pattern is NOT acceptable where SA\*\* is indicated for  $n=4$  in Table 3. Instead, reduce the base mount spacing to 32" and stagger per Figure 9.

# Rafter Attachment Pattern Figure 8

$S_M$  = Base Mount Spacing  
 $S_R$  = Rafter Spacing  
 $n$  = Number Of Rafter Spaces  
 $= S_M / S_R$

## $n = 3$ Rafter Attachment Pattern

For  $S_R = 16''$  o.c. &  $24''$  o.c.

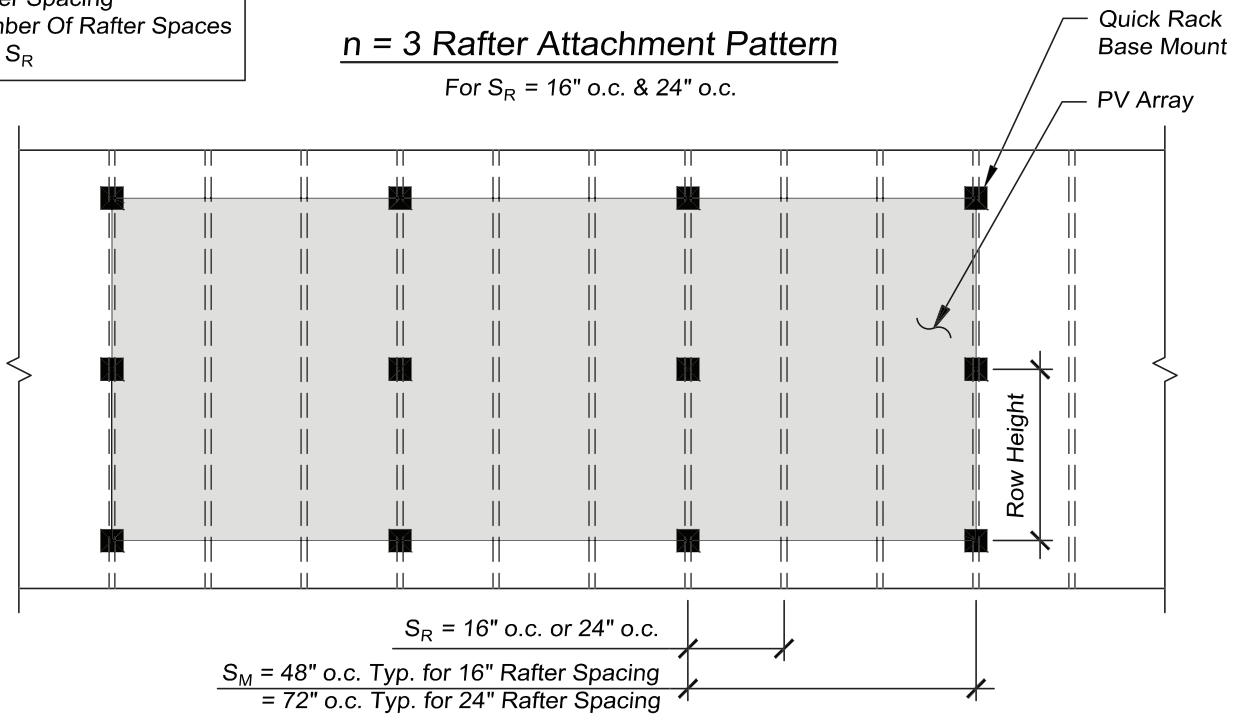

## Staggered Rafter Attachment Pattern To Attain $n = 2$ Equivalence

For  $S_R = 16''$  o.c. &  $24''$  o.c.

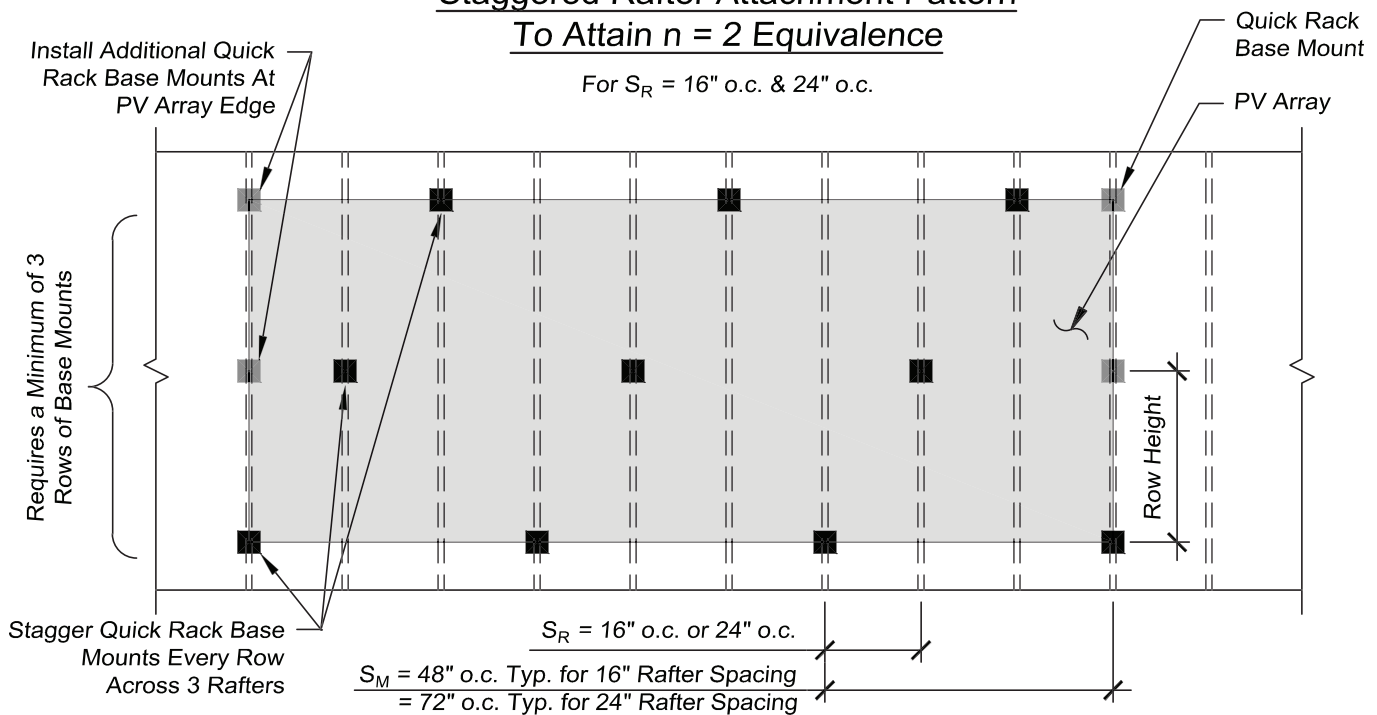

**Note:** This staggered pattern is NOT acceptable where SA\* is indicated for  $n=3$  or SA\*\* is indicated for  $n=4$  in Table 3. Instead, reduce the base mount spacing and stagger per Figure 9.

# Rafter Attachment Pattern Figure 9

$S_M$  = Base Mount Spacing  
 $S_R$  = Rafter Spacing  
 $n$  = Number Of Rafter Spaces  
 $= S_M / S_R$

## $n = 2$ Rafter Attachment Pattern

For  $S_R = 16"$  o.c. &  $24"$  o.c.

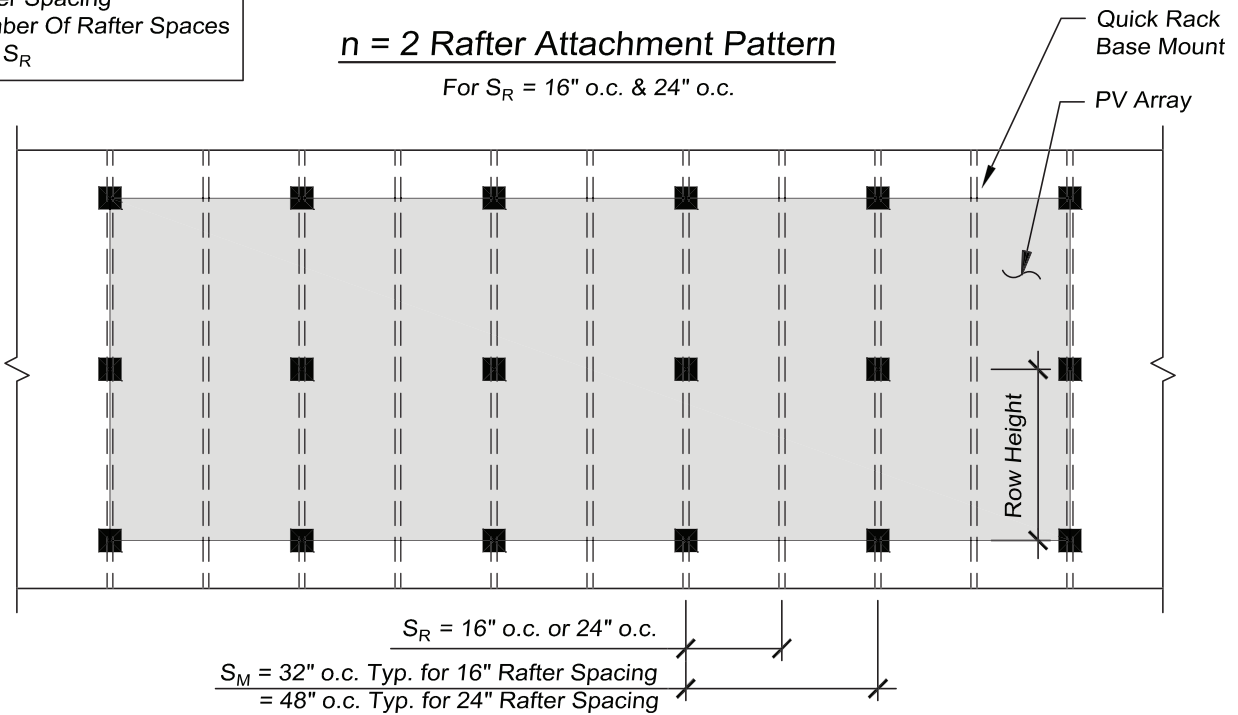

## Staggered Rafter Attachment Pattern To Attain $n = 1$ Equivalence

For  $S_R = 16"$  o.c. &  $24"$  o.c.

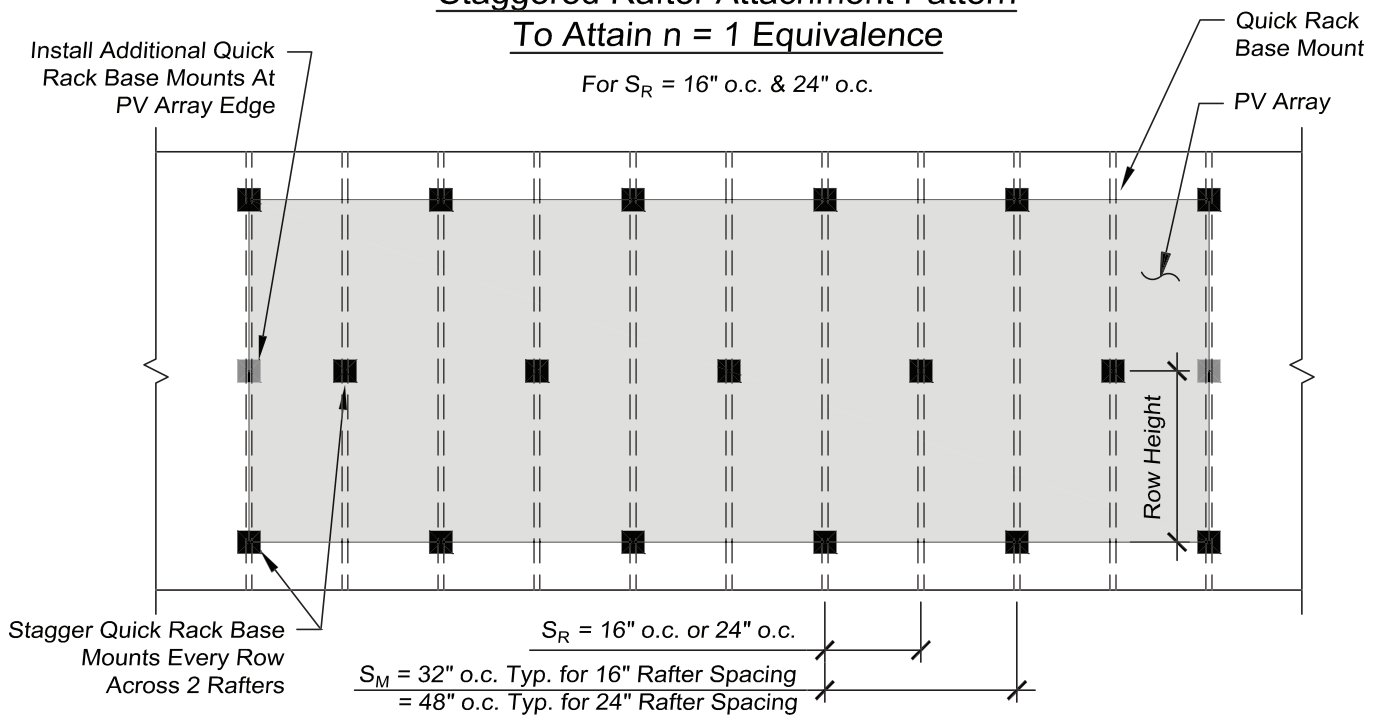

## Rafter Attachment Pattern Figure 10

$S_M$  = Base Mount Spacing  
 $S_R$  = Rafter Spacing  
 $n$  = Number Of Rafter Spaces  
=  $S_M / S_R$

### $n = 1$ Rafter Attachment Pattern

For  $S_R = 16''$  o.c. &  $24''$  o.c.

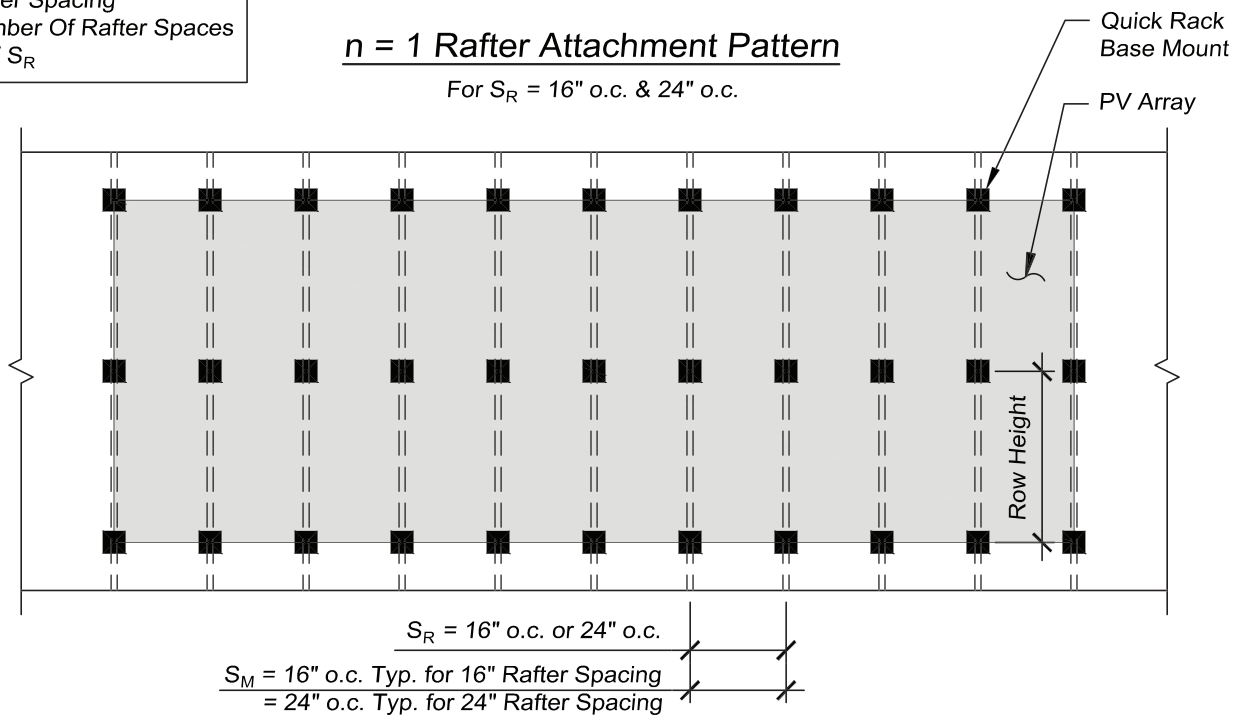

## C. Code Compliance

- 2015 International Building Code compliant
- 2016 California Building Code compliant
- ASCE 7-10 Minimum Design Loads for Buildings and Other Structures compliant
- Conforms to UL STD 2703, ETL listed by Intertek, see page **Ref-15** for compliance requirements.

## D. Approved Modules List

<b>Evaluated and Approved Modules for use with Quick Rack per ANSI/UL 2703 Edition 1</b> Modules load tested at 50 PSF downward, 35 PSF upward, 23.4 PSF down-slope and grounding/bonding tested	Model Dimensions			Maximum Allowable Module Cantilever	
	length (mm)	width (mm)	thickness (mm)	landscape (in)	portrait (in)
<b>LG Solar Mono X, Mono X Ace &amp; Mono X NeON 35mm</b> LGXXS1C-G3, LGXXS1C-A3, LGXXS1C-B3, LGXXS1K-G3, LGXXS1K-A3, LGXXS1K-B3, LGXXN1C-G3, LGXXN1C-A3, LGXXN1C-B3, LGXXA1C-B3	1640	1000	35	17.7	2.7
<b>LG Solar Mono X, Mono X Ace &amp; Mono X NeON 40mm</b> LGXXS1C-G4, LGXXN1K-G4, LGXXN1C-G4, LGXXA1C-G4	1640	1000	40	13.7	2.7
<b>Trina Solar</b> TSM-XXX-PA05.05, TSM-XXX-PA05.08, TSM-XXX-PD05.05, TSM-XXX-PD05.08	1650	992	35	14.2	7.8
<b>Yingli Solar YGE 60 Cell</b> YLXXP-29b 35mm	1650	990	35	7.8	7.8
<b>Suniva Optimus Series 40mm</b> Black OPT XXX-60-4-1B0, Silver OPT XXX-60-4-100	1652	982	40	7.8	n/a
<b>Suniva Optimus Series 35mm</b> Black OPT XXX-60-4-1B0, Black OPT XXX-60-4-1B1, Silver OPT XXX-60-4-100, Silver OPT XXX-60-4-101	1660	990	35	14	n/a
<b>Renesola 156 Series, Clarus, Virtus, &amp; Virtus II</b> JCXXS-24/Bb, JCXXF-24/Bb-b, JCXXS-24/Bb-b, JCXXM-24/Bb, JXXM-24/Bbv, JCXXM-24/Bb, JCXXM-24/Bbh	1640	992	40	15.1	8.8
<b>Hyundai Solar RG-Series</b> HiS-MXXXRG, HiS-SXXXRG	1640	998	35	14.1	7.8
<b>Hyundai Solar MF-Series</b> HiS-SXXXMF	1476	983	35	12.5	7.7
<b>Hyundai Solar MG Series</b> HiS-MXXXMG, HiS-SXXXMG	1645	983	35	14.2	7.7
<b>SolarWorld Sun Module Pro Poly &amp; Plus Mono</b> SWXXX POLY, SWXXX-MONO, SWXXX-MONO BLACK	1675	960	33	14.5	7.8

Note: Module wattage is represented by XXX in product codes.

<b>Evaluated and Approved Modules for use with Quick Rack per ANSI/UL 2703 Edition 1</b> Modules load tested at 50 PSF downward, 35 PSF upward, 23.4 PSF down-slope and grounding/bonding tested	<b>Model Dimensions</b>			<b>Maximum Allowable Module Cantilever</b>	
	<b>length</b> (mm)	<b>width</b> (mm)	<b>thickness</b> (mm)	<b>landscape</b> (in)	<b>portrait</b> (in)
<b>Axitec AXI Power, Premium, &amp; Plus SE</b>					
AC-XXXXP/156-60S, AC-XXXXM/156-60S, AC-XXXXM/156-60S, AC-XXXXP/156-60S, AC-XXXXM/156-60S	1640	992	40	13.7	9.8
<b>Winaico WST-P6 Series</b>					
WST-XXXXP6	1665	999	35	14.4	n/a
<b>Phono Solar Diamond &amp; Onyx Series</b>					
PSXXXXP-20/U, PSXXXXM-20/U, PSXXXXP-20/U, PSXXXXM-20/U	1641	993	40	13.7	7.8
<b>Canadian Solar</b>					
CS6P-XXXXP, CSP-XXXXP-SD	1638	982	40	11-19.7*	n/a
<b>Canadian Solar</b>					
CS6K-XXXXM, CS6K-XXXXM All Black	1650	992	40	11-19.7*	n/a

Note: Module wattage is represented by XXX in product codes.

\*See manufacturer's instructions for location/load specific cantilever values.

<b>Evaluated and Approved Modules for use with Quick Rack per UL SUB 2703 Issue 1</b> Modules load tested at 30 PSF downward, 30 PSF upward and grounding/bonding tested	<b>Model Dimensions</b>			<b>Maximum Allowable Module Cantilever</b>	
	<b>length</b> (mm)	<b>width</b> (mm)	<b>thickness</b> (mm)	<b>landscape</b> (in)	<b>portrait</b> (in)
<b>BenQ Green Triplex</b>					
PM060M02-XXX, PM060P00-XXX, PM245P00-XXX, PM250M01-XXX, PM245P03-XXX	1639	983	40	14.9	9.7
<b>ET Solar</b>					
ET-PXXXXBB, ET-PXXXXWW/WB, ET-MXXXXWW, ET-PXXXXWWG	1640	992	40	14.1	n/a
<b>Yingli Solar YGE 60 Cell</b>					
YLXXXXP-29b 40mm	1650	990	40	7.8 - 17.7*	7.8
<b>Hanwha Solar HSL 60 &amp; HSL 72</b>					
HSL60P6-PB-0-XXXXT, HSL60P6-PB-0-XXXXTW, HSL60P6-PB-0-XXXXTB, HSL60P6-PB-4-XXXXT, HSL60P6-PB-4-XXXXTW, HSL60P6-PB-4-XXXXTB, HSL60P6-PB-1-XXX, HSL60P6-PB-1-XXXB	1636	988	40	15.5	9.8
<b>Canadian Solar</b>					
CS6P-XXXXM, CS6P-XXXXM All Black	1638	983	40	11-19.7*	6.7-7.8*

Note: Module wattage is represented by XXX in product codes.

\*See manufacturer's instructions for location/load specific cantilever values.



## E. Grounding Information

The Quick Rack rail-free mounting system may be used to ground and mount the PV module complying with UL 1703 only when the specific module has been evaluated for grounding and mounting in compliance with the included instructions.

Grounding lug must be visible to inspectors from the perimeter of the array.

To avoid breaking the bonding path during routine maintenance please use one of the following 2 options:

- By replacing base mount cap screw with a second IlSCO GBL-4DBT grounding lug in an undisturbed portion of the array and running the properly sized bare copper wire for over current protection back to the ground fault circuit. Install grounding lug per **page 11** requirements. Make sure all portions of the array are properly grounded in this fashion.
- Replace 2 base mount cap screws with IlSCO GBL-4DBT and use a bare copper wire sized properly for over current protection as a jumper between the 2 grounding lugs. NOTE: This only works when a single column of modules are removed.

**Multiple Use Grounding Pins:** Grounding pins within the Panel Clamp assemblies are multiple use bonding/grounding devices. Module must be adjusted if panel clamps are loosened so there is new metal for the grounding pin to pierce when retightened.

**Grounding Method:** The Quick Rack™ Rail-Free Mounting System by Quick Mount PV® has integrated grounding by use of grounding pins located on each panel clamp, whether it be a 2 inch or 8 inch panel clamp. The grounding pin on the clamp pierces the module frame by torquing a serrated flange nut on the clamp to 13 ft-lbs once the module frame has been inserted into the clamp (see graphic below). The panel clamps electrically bond all module frames together in a single array. Only one IlSCO GBL-4DBT grounding lug is required for an array, limited to 300 modules or 100ft x 100ft. The grounding lug must be installed per Quick Mount PV instructions and use the supplied stainless steel hardware. Enphase micro-inverters and Engage Cable may be used to ground Quick Rack Rail-Free Mounting System in place of grounding lug, if there are a minimum of 3 PV modules connected to the same Engage Cable while all bonded together into a singular array. Micro-inverters or optimizers must be mounted with Quick Mount PV Accessory Frame Bracket or Enphase Frame Mount. See page **Ref-19-20** for Enphase Micro-inverter Grounding Specifics. The grounding of the entire system is intended to be in accordance with the latest edition of the National Electrical Code, including NEC 250: Grounding and Bonding, and NEC 690: Solar Photovoltaic Systems. See pages **Ref-18** for standard grounding path diagram, and page **Ref-21** for systems specifications and ratings.

### Panel Clamps with Integrated Grounding Pins

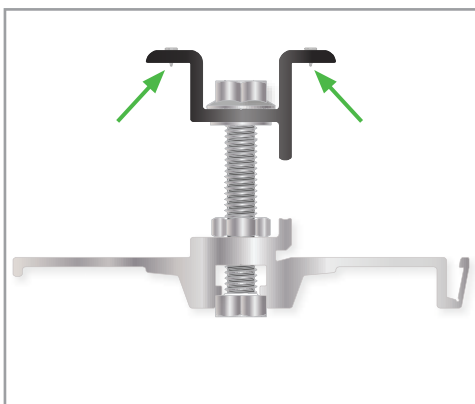

Each panel clamp has integrated grounding pins.

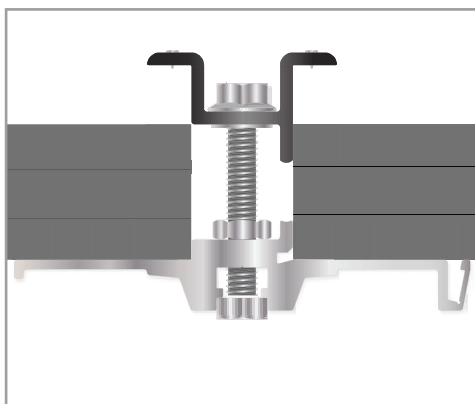

Once both modules have been inserted, tighten clamp down. The clamps can be loosened and re-tightened up to 10 times without compromising the grounding function of the pins.

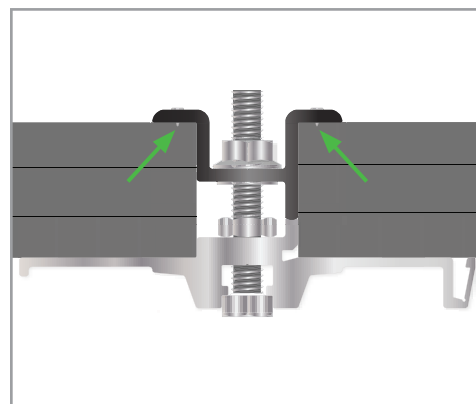

The module is grounded when pins bite into module frame.

# F. Grounding Path Diagrams

## Standard Grounding Path

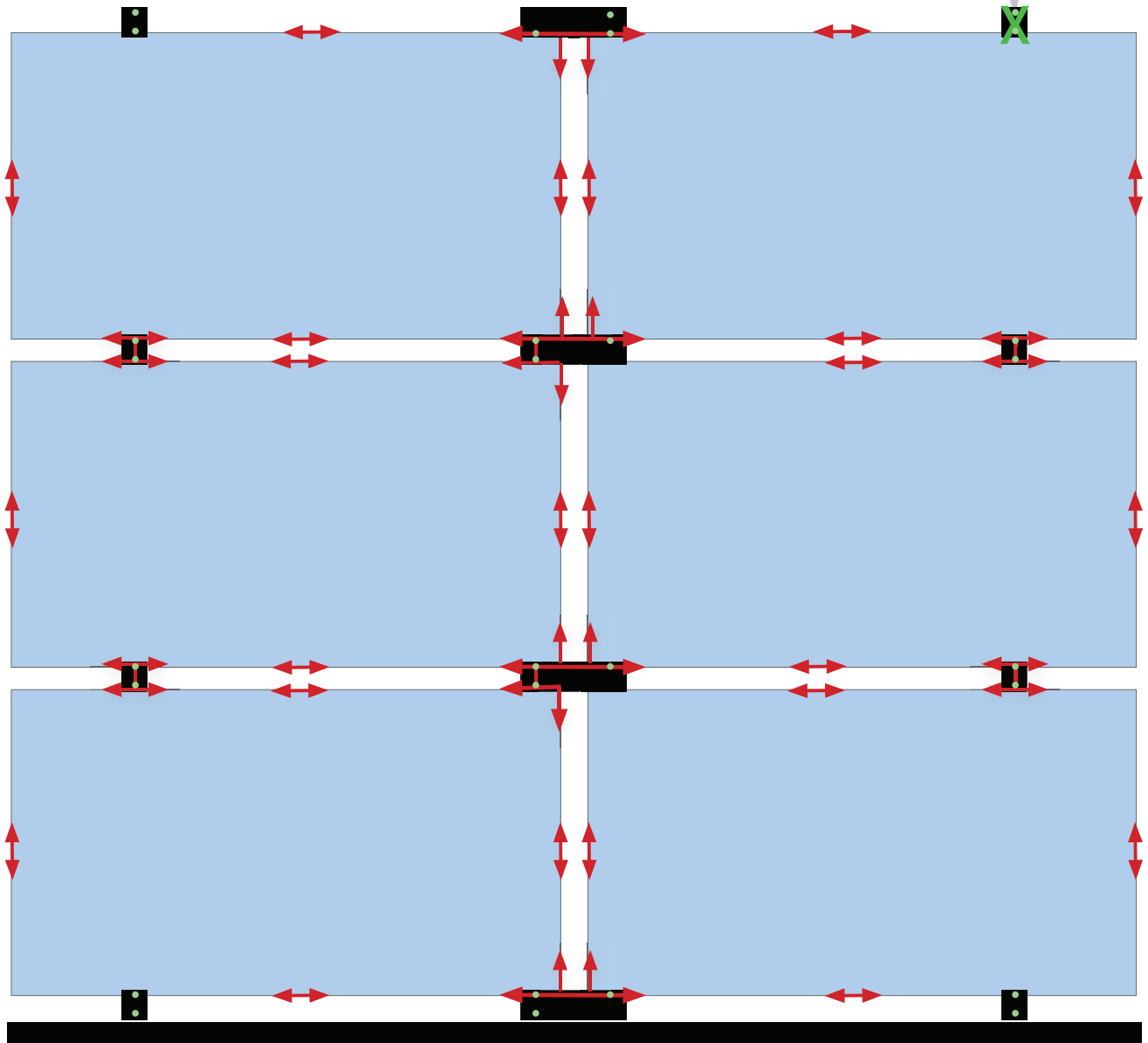
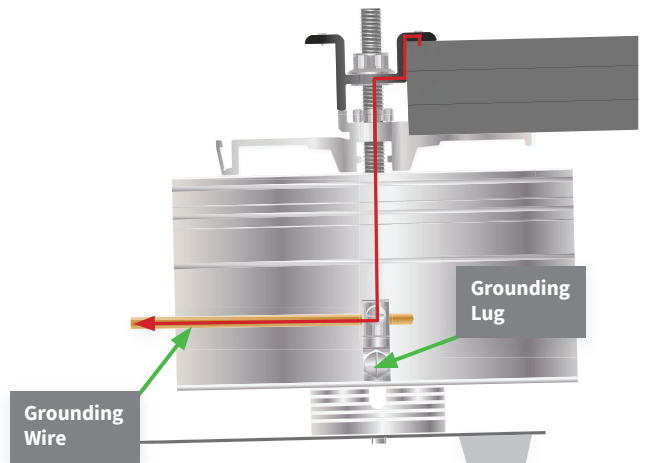
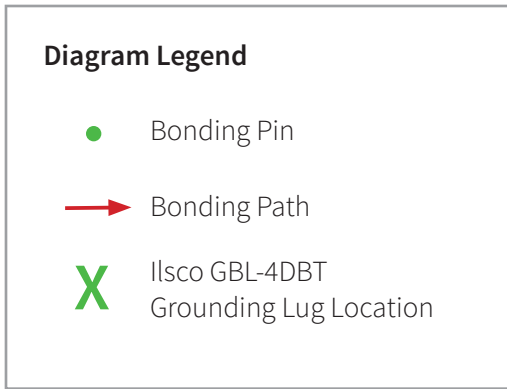

# Micro Inverter Grounding Path

**Diagram Legend**

- Bonding Path
- Trunk Cable Bracket
- Trunk Cable Clip
- 90° Trunk Cable Clip
- Micro Inverter
- Trunk Cable
- PV Wire Clips
- Ground

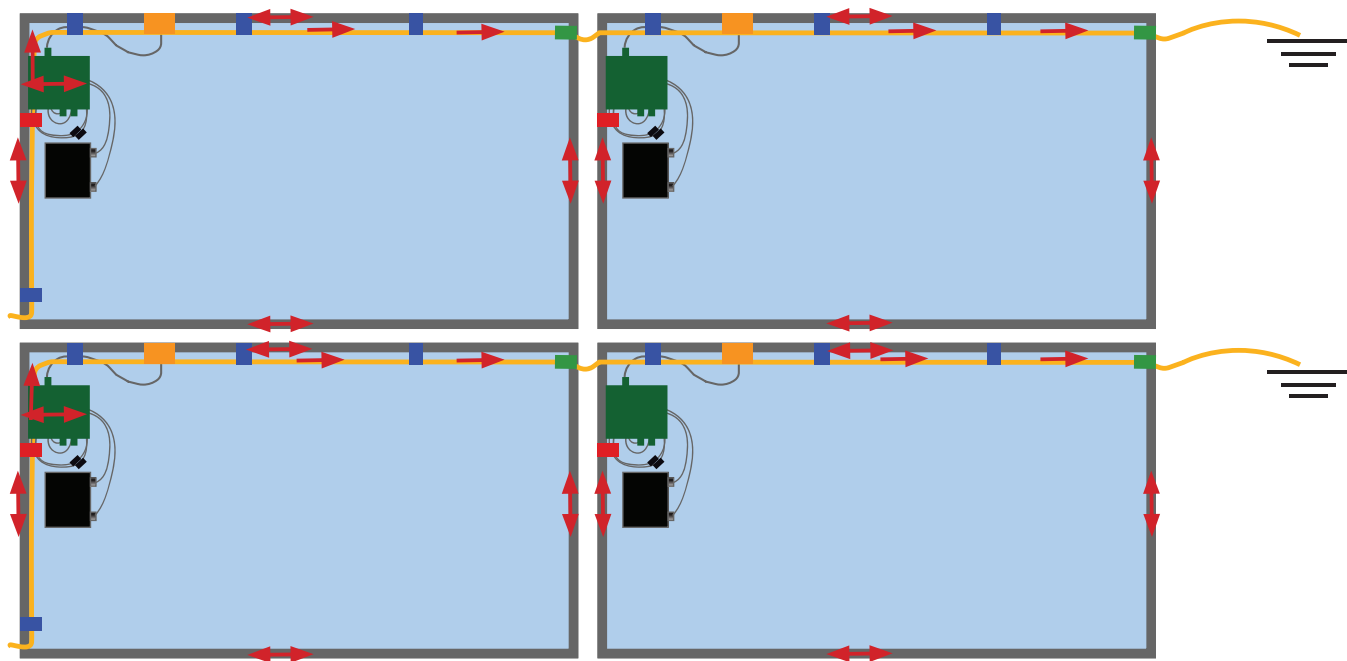

# Enphase® Micro-inverter Grounding Specifics

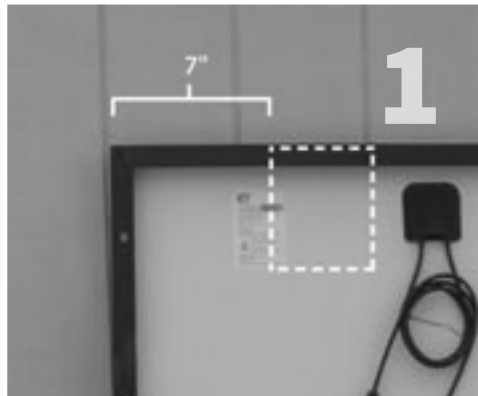

1 In a standard landscape array, the Enphase inverter bracket will be installed approximately 7" in from the edge of the module.



2 Place the bracket clamp over the edge of the module frame.

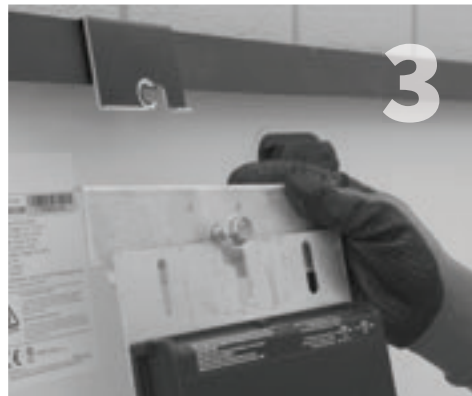

3 With the cap screw threaded into the channel on the bracket, slide the Enphase inverter on top of the bracket with the cap screw in the middle channel on the inverter.



4 Slide the entire unit up under the bracket clamp, and then slightly to the left so that the cap screw holds everything together.



5 Tighten the cap screw with a half-inch socket and torque wrench. Torque to 15 foot-pounds.

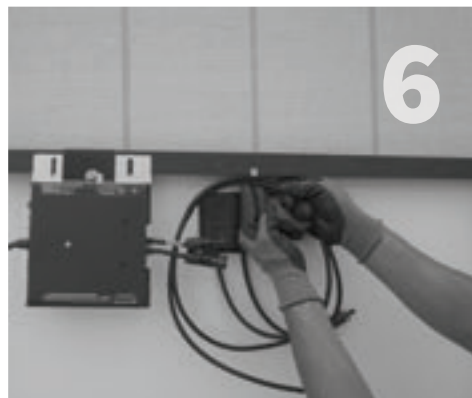

6 Neatly coil the wires and clip to module frame.

## Conditions of Acceptability

1. This description covers the use of a minimum of two Enphase M250 Micro-inverters - attached electrically in parallel to an acceptable PV module frame/racking structure.
2. The micro-inverter models M250-60, M215-60, C250-72 with suffixes may be used with Enphase Engage Cable ETXX-240, ETXX-208, or ETXX-277.
3. Connected inverters must always be mounted to the same mounting structure and connected to the same ground wire.
4. The maximum size output branch circuit protection acceptable for this unit is 20 A.
5. The M250 micro-inverters should not be serviced or removed from their mounting frames until the AC and DC have both been disconnected.
6. When AC and DC are connected, two modules should always be connected and mounted to ensure an acceptable ground path.

## G. System Specifications & Ratings

- Maximum system size: 100ft x 100ft
- Landscape or portrait orientation
- Maximum number of modules: 300
- Torque Specs:
  - Panel Clamps (5/16"-18 bolted connection) = 13 ft-lbs
  - Top Slider Bolt (1/4"-20 bolted connection) = 6 ft-lbs
  - Grounding Lug Connection Bolt (10-32 bolted connection) = 35 in-lbs
  - Grounding Lug Wire Set Screw:
    - » 4-6 AWG: 35 in-lbs
    - » 8 AWG: 25 in-lbs
    - » 10-14 AWG: 20 in-lbs
- IISCO GBL-4DBT Grounding Lug Rated Maximum System Overcurrent Protection (Copper [Cu] Conductor):
  - 14 AWG 15A
  - 12AWG 20A
  - 10AWG 40A
  - 8AWG 90A
  - 6AWG 150A
  - 4AWG 200A
- Maximum Fuse Rating: 20 Amps
- UL SUB 2703 Load Rating at 72" OC mount spacing:
  - Downward pressure - 30psf
  - Upward pressure - 30psf
  - Lateral/Down-slope Load - NA
- UL STD 2703 Max Load Rating at 32" OC mount spacing:
  - Downward pressure - 50psf
  - Upward pressure - 35psf
  - Lateral/Down-slope Load - 23.4psf
- Fire Rating: For a non-integral module or panel, the assembly is to be mounted over a fire resistant roof covering rated for the application. Quick Rack and Type I & 2 listed panels comply with a Class A fire rating when mounted at all possible Quick Rack Base Mount position both with and without the skirt on the front face of the array.

- System Marking:

Quick Rack by Quick Mount PV®  
 Max upward pressure: 35 psf  
 Max downward pressure: 50 psf  
 Max down-slope pressure: 23.4 psf  
 Conforms to UL STD 2703  
 Patents 7,762,027; 8,938,932



- Periodic Re-inspections: If re-inspections yields loose components, loose fasteners, or any corrosion between components, components that are found to be affected are to be replaced immediately.

# H. Engineering Drawings

ITEM NO.	DESCRIPTION	QTY.
1	FLASHING, 9" X 12" X .050", 5052, MILL	1
2	QBLOCK SLIDER, QUICK RACK, 2", 6061-T6, MILL	1
3	TOP SLIDER, QUICK RACK, 6", 6061-T6/6005A-T61, MILL	1
4	CAP SCREW, CUSTOM HEX HEAD, 1/4"-20 X 7/8" UNC-2A, 1/2" HEAD, 18-8 SS	1
5	NUT, SERRATED FLANGE, HEX, 1/4"-20, UNC-2B, 18-8 SS	1
6	STRUCTURAL SCREW, QMPV, T-30 HEX WASHER HEAD, 5/16" X 4-1/2", 18-8SS	1
7	WASHER, SEALING, 5/16" ID X 3/4" OD, EPDM BONDED SS	1
8	SCREW COVER, QBLOCK SLIDER, QUICK RACK, EPDM	1

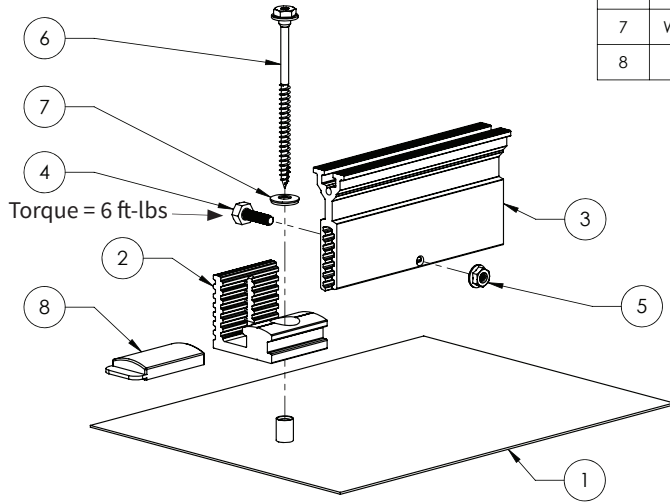

**Quick Mount PV®**

TITLE:  
**QMQR-BM: QUICK RACK, V1.1,  
BASE MOUNT ASSEMBLY**

UNLESS OTHERWISE SPECIFIED: DIMENSIONS ARE IN INCHES TOLERANCES: FRACTIONAL ± 1/8 TWO PLACE DECIMAL ±.19 THREE PLACE DECIMAL ±.094	SIZE <b>A</b>	DRAWN BY: RAD DATE: 7/21/2016	REV <b>3</b>
SCALE: 1:3		WEIGHT: 1.49	SHEET 1 OF 2

**"Controlled Document  
Do Not Copy"**

PROPRIETARY AND CONFIDENTIAL  
THE INFORMATION CONTAINED IN THIS DRAWING IS THE SOLE PROPERTY OF QUICK MOUNT PV. ANY REPRODUCTION IN PART OR AS A WHOLE WITHOUT THE  
WRITTEN PERMISSION OF QUICK MOUNT PV IS PROHIBITED. COPYRIGHT © 2016 QUICK MOUNT PV

DO NOT SCALE DRAWING

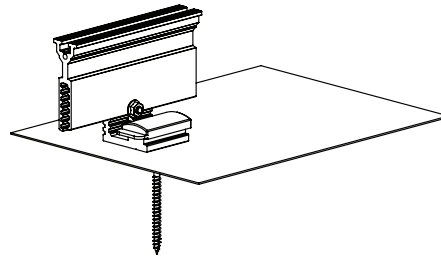
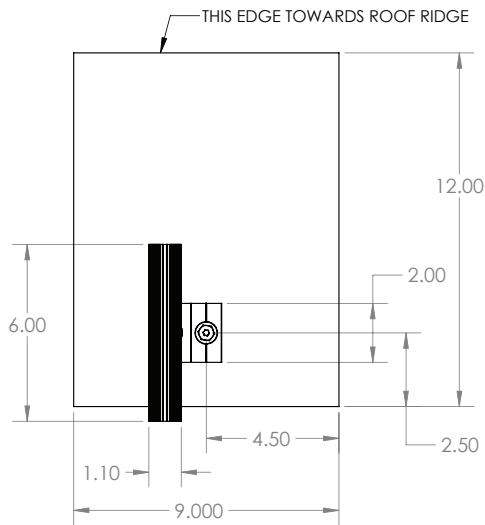

**Quick Mount PV®**

TITLE:  
**QMQR-BM: QUICK RACK, V1.1,  
BASE MOUNT ASSEMBLY**

UNLESS OTHERWISE SPECIFIED: DIMENSIONS ARE IN INCHES TOLERANCES: FRACTIONAL ± 1/8 TWO PLACE DECIMAL ±.19 THREE PLACE DECIMAL ±.094	SIZE <b>A</b>	DRAWN BY: RAD DATE: 7/21/2016	REV <b>3</b>
SCALE: 1:4		WEIGHT: 1.49	SHEET 2 OF 2

**"Controlled Document  
Do Not Copy"**

PROPRIETARY AND CONFIDENTIAL  
THE INFORMATION CONTAINED IN THIS DRAWING IS THE SOLE PROPERTY OF QUICK MOUNT PV. ANY REPRODUCTION IN PART OR AS A WHOLE WITHOUT THE  
WRITTEN PERMISSION OF QUICK MOUNT PV IS PROHIBITED. COPYRIGHT © 2016 QUICK MOUNT PV

DO NOT SCALE DRAWING

ITEM NO.	DESCRIPTION	QTY.
1	CLAMP BASE, QUICK RACK V1.1, 2", 6005A-T5/6061-T6, MILL	1
2	PANEL CLAMP, 33MM, QUICK RACK, V1.1, 2", 6005A-T5/6005A-T61/6061-T6, BRONZE	1
3	CAP SCREW, HEX HEAD, 5/16"-18 X 2" UNC-2A, 18-8 SS	1
4	NUT, JAM, HEX, 5/16-18, UNC-2B, 18-8 SS	1
5	RETAINER RING, EXTERNAL PUSH-ON, 5/16", CIRCULAR, PLASTIC	1
6	NUT, SERRATED FLANGE, HEX, 5/16"-18, UNC-2B, 18-8 SS	1

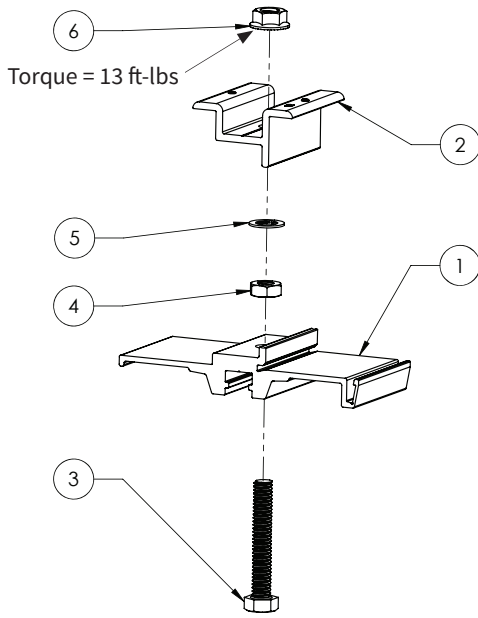

**Quick Mount PV<sup>®</sup>**

TITLE:  
QMQR-CP33.2: QUICK RACK V1.1,  
33MM CLAMP ASSEMBLY, 2 INCH

UNLESS OTHERWISE SPECIFIED: DIMENSIONS ARE IN INCHES TOLERANCES: FRACTIONAL ± 1/8 TWO PLACE DECIMAL ± .19 THREE PLACE DECIMAL ± .094	SIZE <b>A</b>	DRAWN BY: RAD DATE: 7/21/2016	REV <b>3</b>
SCALE: 1:2		WEIGHT: 0.34	SHEET 1 OF 2

**"Controlled Document  
Do Not Copy"**

PROPRIETARY AND CONFIDENTIAL  
THE INFORMATION CONTAINED IN THIS DRAWING IS THE SOLE PROPERTY OF QUICK MOUNT PV. ANY REPRODUCTION IN PART OR AS A WHOLE WITHOUT THE WRITTEN PERMISSION OF QUICK MOUNT PV IS PROHIBITED. COPYRIGHT © 2016 QUICK MOUNT PV

DO NOT SCALE DRAWING

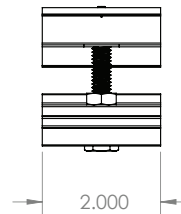
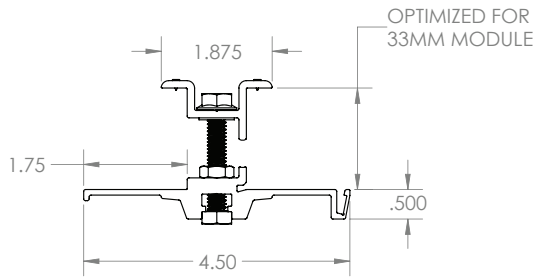
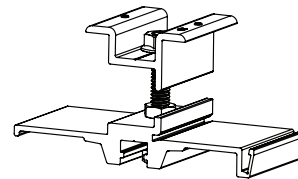

**Quick Mount PV<sup>®</sup>**

TITLE:  
QMQR-CP33.2: QUICK RACK V1.1,  
33MM CLAMP ASSEMBLY, 2 INCH

UNLESS OTHERWISE SPECIFIED: DIMENSIONS ARE IN INCHES TOLERANCES: FRACTIONAL ± 1/8 TWO PLACE DECIMAL ± .19 THREE PLACE DECIMAL ± .094	SIZE <b>A</b>	DRAWN BY: RAD DATE: 7/21/2016	REV <b>3</b>
SCALE: 1:2		WEIGHT: 0.34	SHEET 2 OF 2

**"Controlled Document  
Do Not Copy"**

PROPRIETARY AND CONFIDENTIAL  
THE INFORMATION CONTAINED IN THIS DRAWING IS THE SOLE PROPERTY OF QUICK MOUNT PV. ANY REPRODUCTION IN PART OR AS A WHOLE WITHOUT THE WRITTEN PERMISSION OF QUICK MOUNT PV IS PROHIBITED. COPYRIGHT © 2016 QUICK MOUNT PV

DO NOT SCALE DRAWING

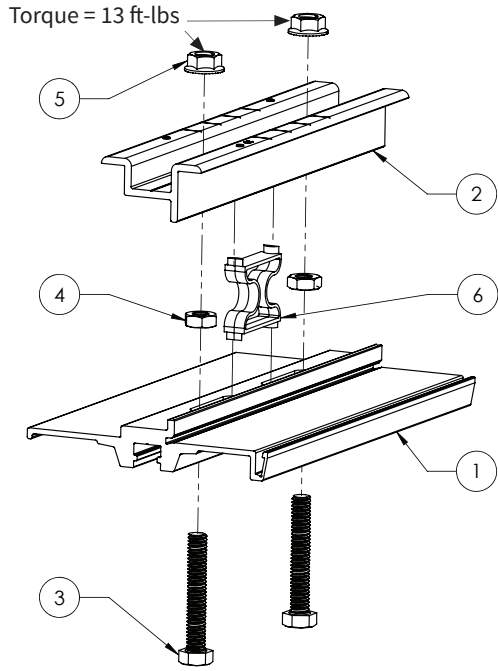

ITEM NO.	DESCRIPTION	QTY.
1	CLAMP BASE, QUICK RACK V1.1, 8", 6005A-T5/6061-T6, MILL	1
2	PANEL CLAMP, 33MM, QUICK RACK, V1.1, 8", 6005A-T5/6005A-T61/6061-T6, BRONZE	1
3	CAP SCREW, HEX HEAD, 5/16"-18 X 2" UNC-2A, 18-8 SS	2
4	NUT, JAM, HEX, 5/16-18, UNC-2B, 18-8 SS	2
5	NUT, SERRATED FLANGE, HEX, 5/16"-18, UNC-2B, 18-8 SS	2
6	CLAMP SPRING, 8", QUICK RACK, V1.1, NYLON 66, BLACK	1

**Quick Mount PV®**

TITLE:  
QMQR-CP33.8: QUICK RACK V1.1,  
33MM CLAMP ASSEMBLY, 8 INCH

UNLESS OTHERWISE SPECIFIED: DIMENSIONS ARE IN INCHES TOLERANCES: FRACTIONAL ± 1/8 TWO PLACE DECIMAL ± .19 THREE PLACE DECIMAL ± .094	SIZE <b>A</b>	DRAWN BY: RAD DATE: 7/21/2016	REV <b>4</b>
DO NOT SCALE DRAWING		SCALE: 1:2 WEIGHT: 1.20	SHEET 1 OF 2

**PROPRIETARY AND CONFIDENTIAL**  
THE INFORMATION CONTAINED IN THIS DRAWING IS THE SOLE PROPERTY OF QUICK MOUNT PV. ANY REPRODUCTION IN PART OR AS A WHOLE WITHOUT THE WRITTEN PERMISSION OF QUICK MOUNT PV IS PROHIBITED. COPYRIGHT © 2016 QUICK MOUNT PV

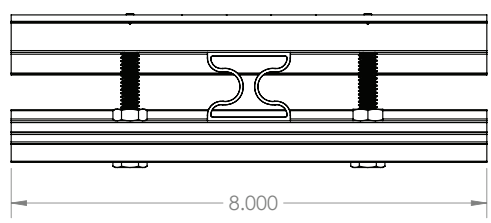
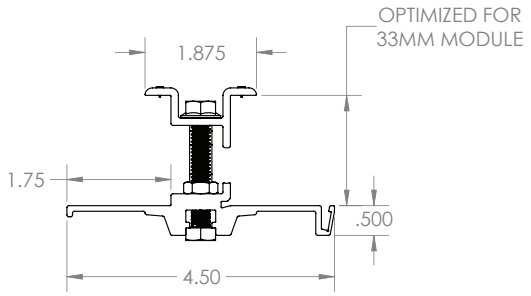
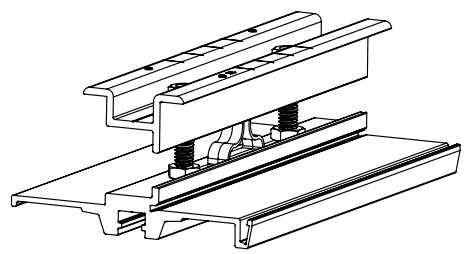

**Quick Mount PV®**

TITLE:  
QMQR-CP33.8: QUICK RACK V1.1,  
33MM CLAMP ASSEMBLY, 8 INCH

UNLESS OTHERWISE SPECIFIED: DIMENSIONS ARE IN INCHES TOLERANCES: FRACTIONAL ± 1/8 TWO PLACE DECIMAL ± .19 THREE PLACE DECIMAL ± .094	SIZE <b>A</b>	DRAWN BY: RAD DATE: 7/21/2016	REV <b>4</b>
DO NOT SCALE DRAWING		SCALE: 1:2 WEIGHT: 1.20	SHEET 2 OF 2

**PROPRIETARY AND CONFIDENTIAL**  
THE INFORMATION CONTAINED IN THIS DRAWING IS THE SOLE PROPERTY OF QUICK MOUNT PV. ANY REPRODUCTION IN PART OR AS A WHOLE WITHOUT THE WRITTEN PERMISSION OF QUICK MOUNT PV IS PROHIBITED. COPYRIGHT © 2016 QUICK MOUNT PV



ITEM NO.	DESCRIPTION	QTY.
1	CLAMP BASE, QUICK RACK V1.1, 2", 6005A-T5/6061-T6, MILL	1
2	PANEL CLAMP, 35MM, QUICK RACK, V1.1, 2", 6005A-T5/6005A-T61/6061-T6, BRONZE	1
3	CAP SCREW, HEX HEAD, 5/16"-18 X 2" UNC-2A, 18-8 SS	1
4	NUT, JAM, HEX, 5/16-18, UNC-2B, 18-8 SS	1
5	RETAINER RING, EXTERNAL PUSH-ON, 5/16", CIRCULAR, PLASTIC	1
6	NUT, SERRATED FLANGE, HEX, 5/16"-18, UNC-2B, 18-8 SS	1

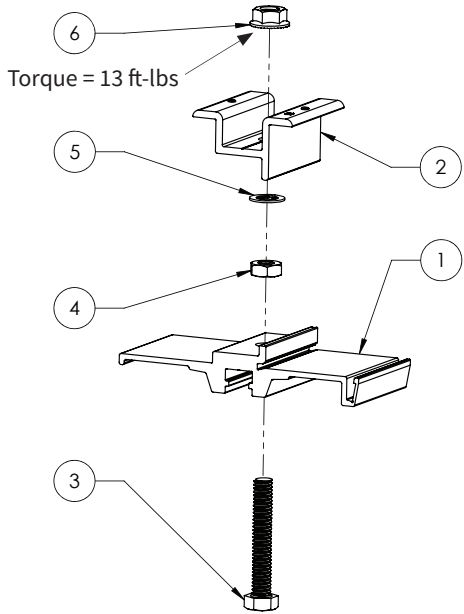

**Quick Mount PV<sup>®</sup>**

TITLE:  
QMQR-CP35.2: QUICK RACK V1.1,  
35MM CLAMP ASSEMBLY, 2 INCH

UNLESS OTHERWISE SPECIFIED: DIMENSIONS ARE IN INCHES TOLERANCES: FRACTIONAL ± 1/8 TWO PLACE DECIMAL ±.19 THREE PLACE DECIMAL ±.094	SIZE <b>A</b>	DRAWN BY: RAD DATE: 7/21/2016	REV <b>7</b>
SCALE: 1:2		WEIGHT: 0.34	SHEET 1 OF 2

**PROPRIETARY AND CONFIDENTIAL**  
THE INFORMATION CONTAINED IN THIS DRAWING IS THE SOLE PROPERTY OF QUICK MOUNT PV. ANY REPRODUCTION IN PART OR AS A WHOLE WITHOUT THE WRITTEN PERMISSION OF QUICK MOUNT PV IS PROHIBITED. **COPYRIGHT © 2016 QUICK MOUNT PV**

**Controlled Document**  
**Do Not Copy**

DO NOT SCALE DRAWING

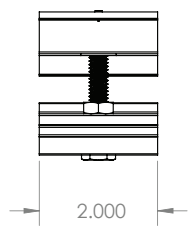
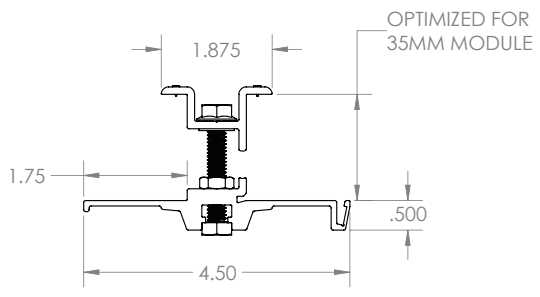
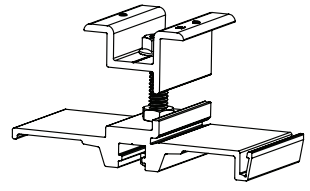

**Quick Mount PV<sup>®</sup>**

TITLE:  
QMQR-CP35.2: QUICK RACK V1.1,  
35MM CLAMP ASSEMBLY, 2 INCH

UNLESS OTHERWISE SPECIFIED: DIMENSIONS ARE IN INCHES TOLERANCES: FRACTIONAL ± 1/8 TWO PLACE DECIMAL ±.19 THREE PLACE DECIMAL ±.094	SIZE <b>A</b>	DRAWN BY: RAD DATE: 7/21/2016	REV <b>7</b>
SCALE: 1:2		WEIGHT: 0.34	SHEET 2 OF 2

**PROPRIETARY AND CONFIDENTIAL**  
THE INFORMATION CONTAINED IN THIS DRAWING IS THE SOLE PROPERTY OF QUICK MOUNT PV. ANY REPRODUCTION IN PART OR AS A WHOLE WITHOUT THE WRITTEN PERMISSION OF QUICK MOUNT PV IS PROHIBITED. **COPYRIGHT © 2016 QUICK MOUNT PV**

**Controlled Document**  
**Do Not Copy**

DO NOT SCALE DRAWING

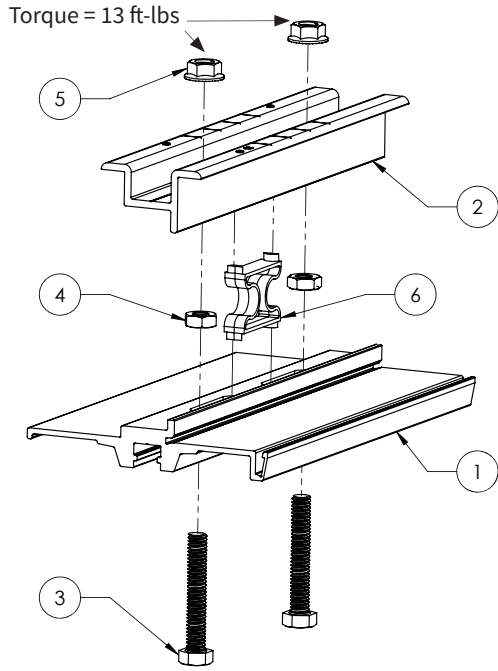

ITEM NO.	DESCRIPTION	QTY.
1	CLAMP BASE, QUICK RACK V1.1, 8", 6005A-T5/6061-T6, MILL	1
2	PANEL CLAMP, 35MM, QUICK RACK, V1.1, 8", 6005A-T5/6005A-T61/6061-T6, BRONZE	1
3	CAP SCREW, HEX HEAD, 5/16"-18 X 2" UNC-2A, 18-8 SS	2
4	NUT, JAM, HEX, 5/16-18, UNC-2B, 18-8 SS	2
5	NUT, SERRATED FLANGE, HEX, 5/16"-18, UNC-2B, 18-8 SS	2
6	CLAMP SPRING, 8 INCH, QUICK RACK, V1.1, NYLON 66, BLACK	1

**Quick Mount PV®**

TITLE:  
QMQR-CP35.8: QUICK RACK V1.1,  
35MM CLAMP ASSEMBLY, 8 INCH

UNLESS OTHERWISE SPECIFIED: DIMENSIONS ARE IN INCHES TOLERANCES: FRACTIONAL ± 1/8 TWO PLACE DECIMAL ± .19 THREE PLACE DECIMAL ± .094	SIZE <b>A</b>	DRAWN BY: RAD DATE: 7/21/2016	REV <b>8</b>
SCALE: 1:2		WEIGHT: 1.21	SHEET 1 OF 2

**"Controlled Document  
Do Not Copy"**

PROPRIETARY AND CONFIDENTIAL  
THE INFORMATION CONTAINED IN THIS DRAWING IS THE SOLE PROPERTY OF QUICK MOUNT PV. ANY REPRODUCTION IN PART OR AS A WHOLE WITHOUT THE WRITTEN PERMISSION OF QUICK MOUNT PV IS PROHIBITED. COPYRIGHT © 2016 QUICK MOUNT PV

DO NOT SCALE DRAWING

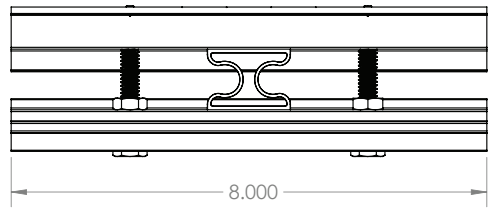
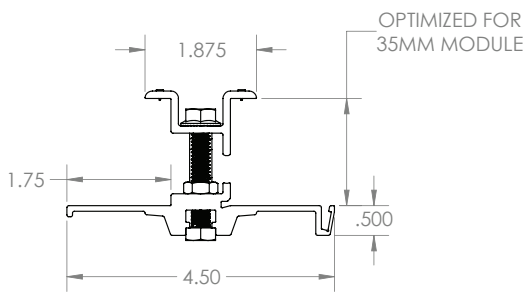
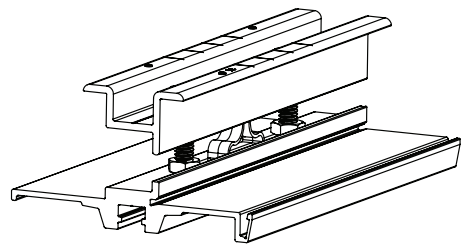

**Quick Mount PV®**

TITLE:  
QMQR-CP35.8: QUICK RACK V1.1,  
35MM CLAMP ASSEMBLY, 8 INCH

UNLESS OTHERWISE SPECIFIED: DIMENSIONS ARE IN INCHES TOLERANCES: FRACTIONAL ± 1/8 TWO PLACE DECIMAL ± .19 THREE PLACE DECIMAL ± .094	SIZE <b>A</b>	DRAWN BY: RAD DATE: 7/21/2016	REV <b>8</b>
SCALE: 1:2		WEIGHT: 1.21	SHEET 2 OF 2

**"Controlled Document  
Do Not Copy"**

PROPRIETARY AND CONFIDENTIAL  
THE INFORMATION CONTAINED IN THIS DRAWING IS THE SOLE PROPERTY OF QUICK MOUNT PV. ANY REPRODUCTION IN PART OR AS A WHOLE WITHOUT THE WRITTEN PERMISSION OF QUICK MOUNT PV IS PROHIBITED. COPYRIGHT © 2016 QUICK MOUNT PV

DO NOT SCALE DRAWING

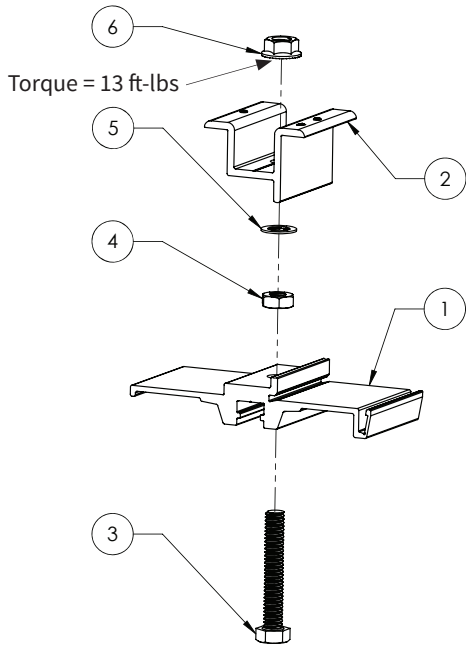

ITEM NO.	DESCRIPTION	QTY.
1	CLAMP BASE, QUICK RACK V1.1, 2", 6005A-T5/6061-T6, MILL	1
2	PANEL CLAMP, 40MM, QUICK RACK, V1.1, 2", 6005A-T5/6005A-T61/6061-T6, BRONZE	1
3	CAP SCREW, HEX HEAD, 5/16"-18 X 2" UNC-2A, 18-8 SS	1
4	NUT, JAM, HEX, 5/16-18, UNC-2B, 18-8 SS	1
5	RETAINER RING, EXTERNAL PUSH-ON, 5/16", CIRCULAR, PLASTIC	1
6	NUT, SERRATED FLANGE, HEX, 5/16"-18, UNC-2B, 18-8 SS	1

**Quick Mount PV<sup>®</sup>**

TITLE:  
QMQR-CP40.2: QUICK RACK V1.1,  
40MM CLAMP ASSEMBLY, 2 INCH

UNLESS OTHERWISE SPECIFIED: DIMENSIONS ARE IN INCHES TOLERANCES: FRACTIONAL ± 1/8 TWO PLACE DECIMAL ±.19 THREE PLACE DECIMAL ±.094	SIZE	DRAWN BY: RAD	REV
	<b>A</b>	DATE: 7/21/2016	<b>6</b>
	SCALE: 1:2	WEIGHT: 0.65	SHEET 1 OF 2

**"Controlled Document  
Do Not Copy"**

PROPRIETARY AND CONFIDENTIAL  
THE INFORMATION CONTAINED IN THIS DRAWING IS THE SOLE PROPERTY OF QUICK MOUNT PV. ANY REPRODUCTION IN PART OR AS A WHOLE WITHOUT THE WRITTEN PERMISSION OF QUICK MOUNT PV IS PROHIBITED. COPYRIGHT © 2016 QUICK MOUNT PV

DO NOT SCALE DRAWING

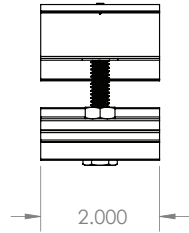
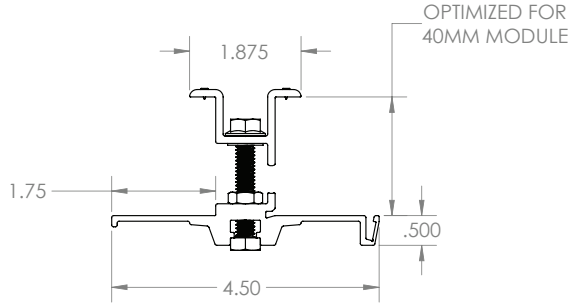
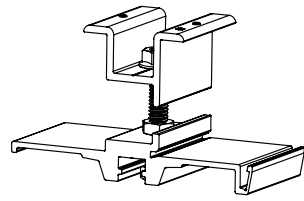

**Quick Mount PV<sup>®</sup>**

TITLE:  
QMQR-CP40.2: QUICK RACK V1.1,  
40MM CLAMP ASSEMBLY, 2 INCH

UNLESS OTHERWISE SPECIFIED: DIMENSIONS ARE IN INCHES TOLERANCES: FRACTIONAL ± 1/8 TWO PLACE DECIMAL ±.19 THREE PLACE DECIMAL ±.094	SIZE	DRAWN BY: RAD	REV
	<b>A</b>	DATE: 7/21/2016	<b>6</b>
	SCALE: 1:2	WEIGHT: 0.65	SHEET 2 OF 2

**"Controlled Document  
Do Not Copy"**

PROPRIETARY AND CONFIDENTIAL  
THE INFORMATION CONTAINED IN THIS DRAWING IS THE SOLE PROPERTY OF QUICK MOUNT PV. ANY REPRODUCTION IN PART OR AS A WHOLE WITHOUT THE WRITTEN PERMISSION OF QUICK MOUNT PV IS PROHIBITED. COPYRIGHT © 2016 QUICK MOUNT PV

DO NOT SCALE DRAWING

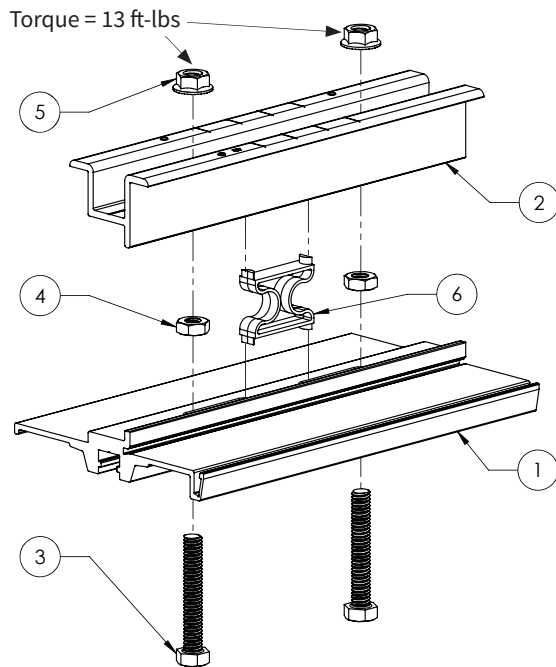

ITEM NO.	DESCRIPTION	QTY.
1	CLAMP BASE, QUICK RACK V1.1, 8", 6005A-T5/6061-T6, MILL	1
2	PANEL CLAMP, 40MM, QUICK RACK, V1.1, 8", 6005A-T5/6005A-T61/6061-T6, BRONZE	1
3	CAP SCREW, HEX HEAD, 5/16"-18 X 2" UNC-2A, 18-8 SS	2
4	NUT, JAM, HEX, 5/16-18, UNC-2B, 18-8 SS	2
5	NUT, SERRATED FLANGE, HEX, 5/16"-18, UNC-2B, 18-8 SS	2
6	CLAMP SPRING, 8 INCH, QUICK RACK, V1.1, NYLON 66, BLACK	1

Quick Mount PV®

TITLE:  
QMQR-CP40.8: QUICK RACK V1.1,  
40MM CLAMP ASSEMBLY, 8 INCH

"Controlled Document  
Do Not Copy"

UNLESS OTHERWISE SPECIFIED: DIMENSIONS ARE IN INCHES TOLERANCES: FRACTIONAL ± 1/8 TWO PLACE DECIMAL ±.19 THREE PLACE DECIMAL ±.094	SIZE <b>A</b>	DRAWN BY: RAD DATE: 7/21/2016	REV 7
SCALE: 1:2	WEIGHT: 1.25	SHEET 1 OF 2	

PROPRIETARY AND CONFIDENTIAL  
THE INFORMATION CONTAINED IN THIS DRAWING IS THE SOLE PROPERTY OF QUICK MOUNT PV. ANY REPRODUCTION IN PART OR AS A WHOLE WITHOUT THE WRITTEN PERMISSION OF QUICK MOUNT PV IS PROHIBITED. COPYRIGHT © 2016 QUICK MOUNT PV

DO NOT SCALE DRAWING

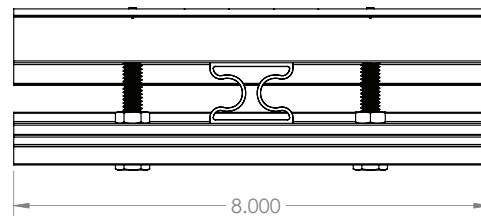
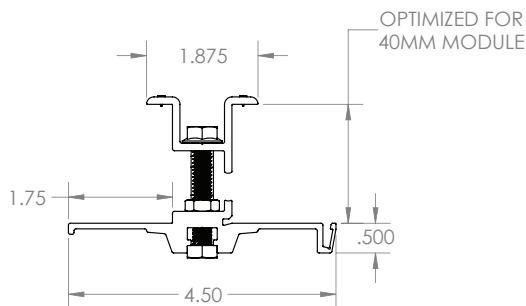
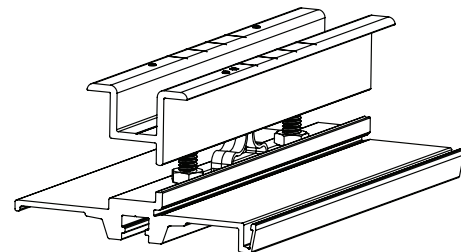

Quick Mount PV®

TITLE:  
QMQR-CP40.8: QUICK RACK V1.1,  
40MM CLAMP ASSEMBLY, 8 INCH

"Controlled Document  
Do Not Copy"

UNLESS OTHERWISE SPECIFIED: DIMENSIONS ARE IN INCHES TOLERANCES: FRACTIONAL ± 1/8 TWO PLACE DECIMAL ±.19 THREE PLACE DECIMAL ±.094	SIZE <b>A</b>	DRAWN BY: RAD DATE: 7/21/2016	REV 7
SCALE: 1:2	WEIGHT: 1.25	SHEET 2 OF 2	

PROPRIETARY AND CONFIDENTIAL  
THE INFORMATION CONTAINED IN THIS DRAWING IS THE SOLE PROPERTY OF QUICK MOUNT PV. ANY REPRODUCTION IN PART OR AS A WHOLE WITHOUT THE WRITTEN PERMISSION OF QUICK MOUNT PV IS PROHIBITED. COPYRIGHT © 2016 QUICK MOUNT PV

DO NOT SCALE DRAWING

ITEM NO.	DESCRIPTION	QTY.
1	SKIRT, QUICK RACK, V1.1, 65.80", 6063-T6, BRONZE	1
2	SKIRT CLIP, QUICK RACK, V1.1, 2", 6063-T6, MILL	2

ITEM 1 : AVAILABLE IN 65.80" AND 66.70" LENGTHS

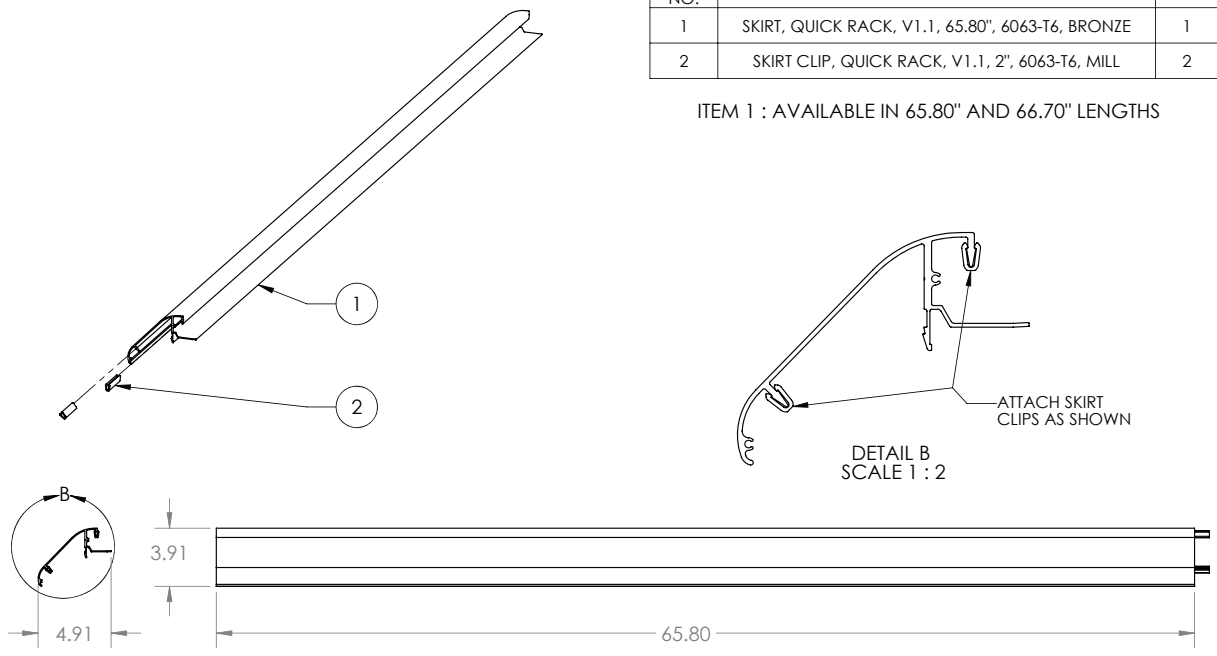

**Quick Mount PV<sup>®</sup>**

TITLE:  
QMQR-SL: SKIRT ASSEMBLY, QUICK RACK, V1.1, LANDSCAPE

UNLESS OTHERWISE SPECIFIED: DIMENSIONS ARE IN INCHES TOLERANCES: FRACTIONAL ± 1/8 TWO PLACE DECIMAL ±.18 THREE PLACE DECIMAL ±.125	SIZE <b>A</b>	DRAWN BY: RAD DATE: 9/24/2015	REV <b>2</b>
---	------------------	----------------------------------	-----------------

SCALE: 1:8 WEIGHT: 5.94 SHEET 1 OF 1

**PROPRIETARY AND CONFIDENTIAL**  
THE INFORMATION CONTAINED IN THIS DRAWING IS THE SOLE PROPERTY OF QUICK MOUNT PV. ANY REPRODUCTION IN PART OR AS A WHOLE WITHOUT THE WRITTEN PERMISSION OF QUICK MOUNT PV IS PROHIBITED.

ITEM NO.	DESCRIPTION	QTY.
1	SKIRT, QUICK RACK, V1.1, 40.125", 6063-T6, BRONZE	1
2	SKIRT CLIP, QUICK RACK, V1.1, 2", 6063-T6, MILL	2

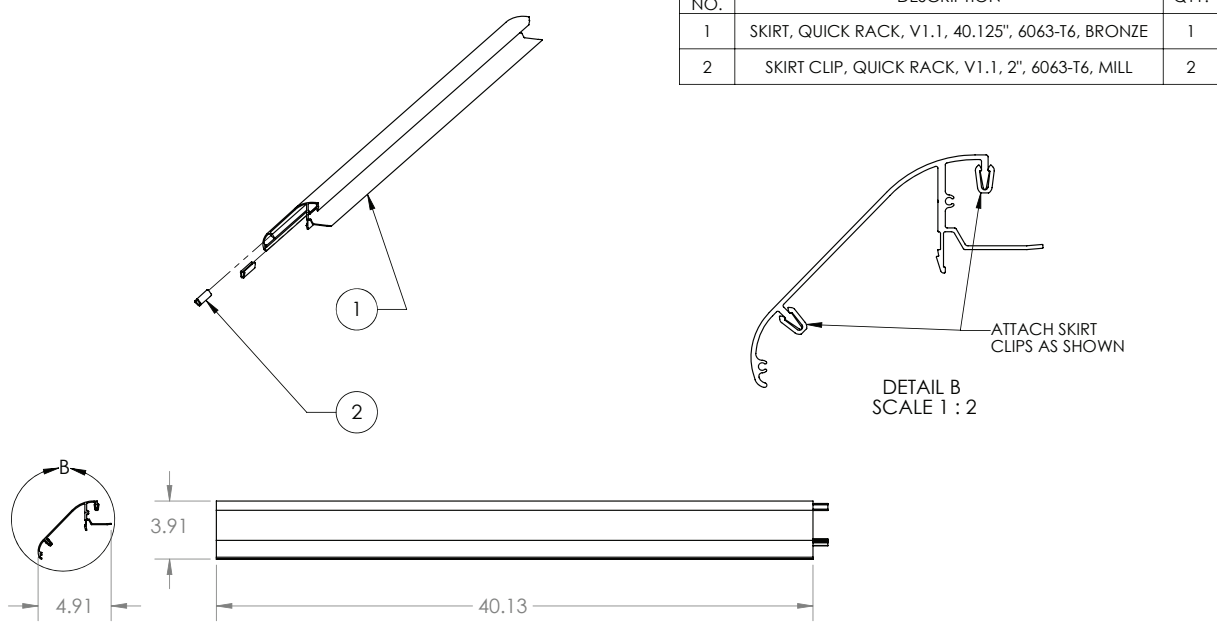

**Quick Mount PV<sup>®</sup>**

TITLE:  
QMQR-SM: SKIRT ASSEMBLY, QUICK RACK, V1.1, 40.125"

UNLESS OTHERWISE SPECIFIED: DIMENSIONS ARE IN INCHES TOLERANCES: FRACTIONAL ± 1/8 TWO PLACE DECIMAL ±.18 THREE PLACE DECIMAL ±.125	SIZE <b>A</b>	DRAWN BY: RAD DATE: 2/28/2014	REV <b>1</b>
---	------------------	----------------------------------	-----------------

SCALE: 1:8 WEIGHT: 3.64 SHEET 1 OF 1

**PROPRIETARY AND CONFIDENTIAL**  
THE INFORMATION CONTAINED IN THIS DRAWING IS THE SOLE PROPERTY OF QUICK MOUNT PV. ANY REPRODUCTION IN PART OR AS A WHOLE WITHOUT THE WRITTEN PERMISSION OF QUICK MOUNT PV IS PROHIBITED.

DO NOT SCALE DRAWING

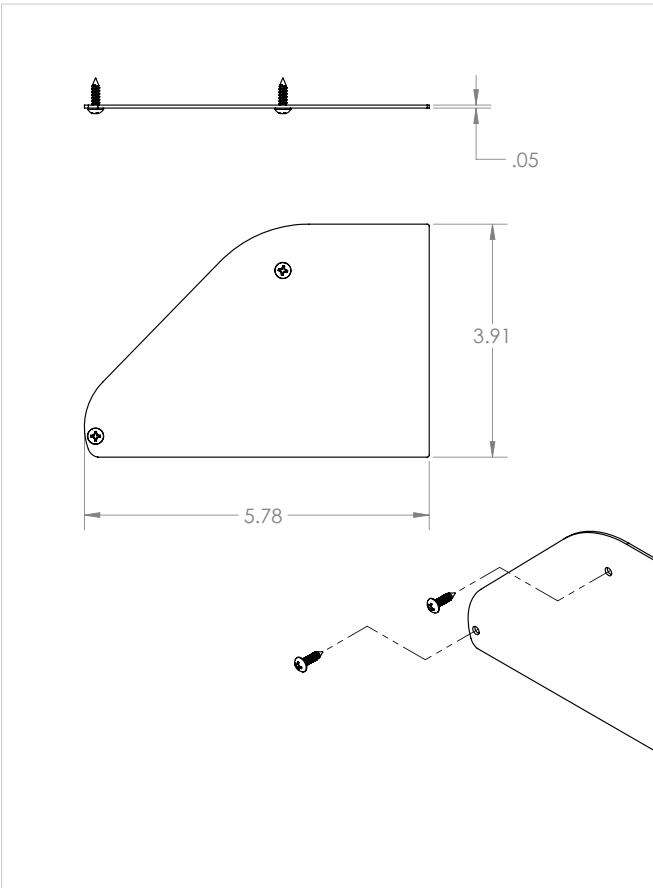

ITEM NO.	DESCRIPTION	QTY.
1	END CAP, SKIRT, RIGHT, QUICK RACK V1.1, 5005-H34 - BRONZE	1
2	END CAP, SKIRT, LEFT, QUICK RACK V1.1, 5005-H34 - BRONZE	1
3	SCREW, SHEET METAL, #6 X 1/2", 18-8SS - BLACK MARKOTE	4

**PROPRIETARY AND CONFIDENTIAL**  
 THE INFORMATION CONTAINED IN THIS DRAWING IS THE SOLE PROPERTY OF QUICK MOUNT PV. ANY REPRODUCTION IN PART OR AS A WHOLE WITHOUT THE WRITTEN PERMISSION OF QUICK MOUNT PV IS PROHIBITED.

DO NOT SCALE DRAWING

**Quick Mount PV®**

TITLE:  
**QMQR-SC: END CAP, SKIRT, QUICK RACK V1.1**

UNLESS OTHERWISE SPECIFIED:  
 DIMENSIONS ARE IN INCHES  
 TOLERANCES:  
 FRACTIONAL ± 1/8  
 TWO PLACE DECIMAL ± .18  
 THREE PLACE DECIMAL ± .125

SIZE	DRAWN BY: RAD	REV
<b>A</b>	DATE: 2/28/2014	1

SCALE: 1:2 WEIGHT: 0.19 SHEET 1 OF 1

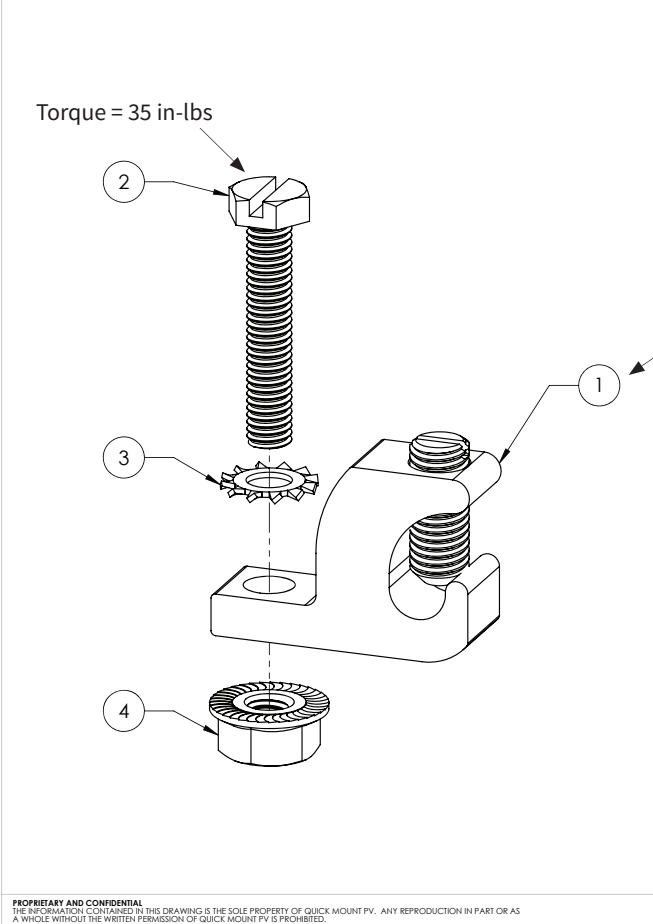

ITEM NO.	DESCRIPTION	QTY.
1	GROUND LUG, 4-14 AWG, COPPER-TIN PLATED, WITH SET SCREW	1
2	CAP SCREW, SLOTTED HEX HEAD, 10-32 X 1" UNF-2A, 18-8 SS	1
3	WASHER, STAR, #10, 18-8SS	1
4	NUT, SERRATED FLANGE, HEX, 10-32, UNF-2B, 18-8 SS	1

ITEM 1: ILSCO CORP. PART NUMBER GBL-4DBT

- Set Screw Torque Specs:**
- 4-6 AWG: 35 in-lbs
  - 8 AWG: 25 in-lbs
  - 10-14 AWG: 20 in-lbs
- \* Recommend use of conductor compound, Deox, between all mounting surfaces.
  - \* A minimum of 1/4" clearance required between bare copper wire and aluminum.

**PROPRIETARY AND CONFIDENTIAL**  
 THE INFORMATION CONTAINED IN THIS DRAWING IS THE SOLE PROPERTY OF QUICK MOUNT PV. ANY REPRODUCTION IN PART OR AS A WHOLE WITHOUT THE WRITTEN PERMISSION OF QUICK MOUNT PV IS PROHIBITED.

DO NOT SCALE DRAWING

**Quick Mount PV®**

TITLE:  
**QMQR-GL: GROUNDING LUG ASSEMBLY, QUICK RACK V1.1**

UNLESS OTHERWISE SPECIFIED:  
 DIMENSIONS ARE IN INCHES  
 TOLERANCES:  
 FRACTIONAL ± 1/8  
 TWO PLACE DECIMAL ± .18  
 THREE PLACE DECIMAL ± .125

SIZE	DRAWN BY: RAD	REV
<b>A</b>	DATE: 9/22/2015	2

SCALE: 2:1 WEIGHT: 0.08 SHEET 1 OF 1

# Notes

---

# Quick Mount PV<sup>®</sup>

RESPECT THE ROOF



Intertek  
4008516

UL STD 2703



Made in USA