

APPLICATION:

The patented SolarWedge® product line provides an easy-to-install and economical low-slope roof solution for a 1, 5, 10 or 15 degree tilted roof mounted system. SolarWedge® integrates with Professional Solar's (ProSolar®) patented RoofTrac® "top-down" clamps and support rails. It is Class A low-slope roof fire rated for Type 1 and 2 solar modules with no height restrictions.



WARNING:

All ProSolar® products are engineered and tested to withstand stated specifications (as stated on published engineering documents) when installed properly. Failure to install properly may decrease the performance of installation.



SAFETY:

All regional safety requirements should be followed when installing ProSolar® products. All tools and equipment located on the roof should be secured to avoid falling object hazards. All equipment/tools should be properly maintained and inspected prior to use. Any exposed studs should be protectively capped to avoid injury. This racking system may be used to ground and/or mount a PV module complying with UL 1703 only when the specific module frame has been evaluated for grounding and/or mounting compliance with the included instructions. This installation manual is intended for use by professional installers with a working knowledge of construction principles.

Symbol Legend



Explanation or Install Tip



Important Product Performance Information



Critical for Safety

Tool List

- Cordless impact wrench
- Cordless drill with 1/4" diameter, long drill bit
- 3/4" (18mm) titanium plated self-starting #3 Unibit®
- 1/2" self-starting #10 Unibit®
- 9/16" open-end wrench
- Adjustable pliers
- 9/16" Deep Socket
- 1/2" box-end wrench
- Tape measure
- String line (chalk line)
- Lumber Crayon
- Sharpie® Pen
- Stiff Paint Brush
- Dead-blow Hammer (approx. 21 oz)
- Precision stud sensor

System Layout & Chalk Line Marking

Prior to beginning attachment work, the system roof layout should be defined.

A drawing or sketch, prior to roof work, is recommended.

Upon finalizing layout, use chalk lines to mark support rail locations. The chalk lines will be used to align SolarWedge® attachment points.

Note: The rail distance from the end of the module will vary based on module size.

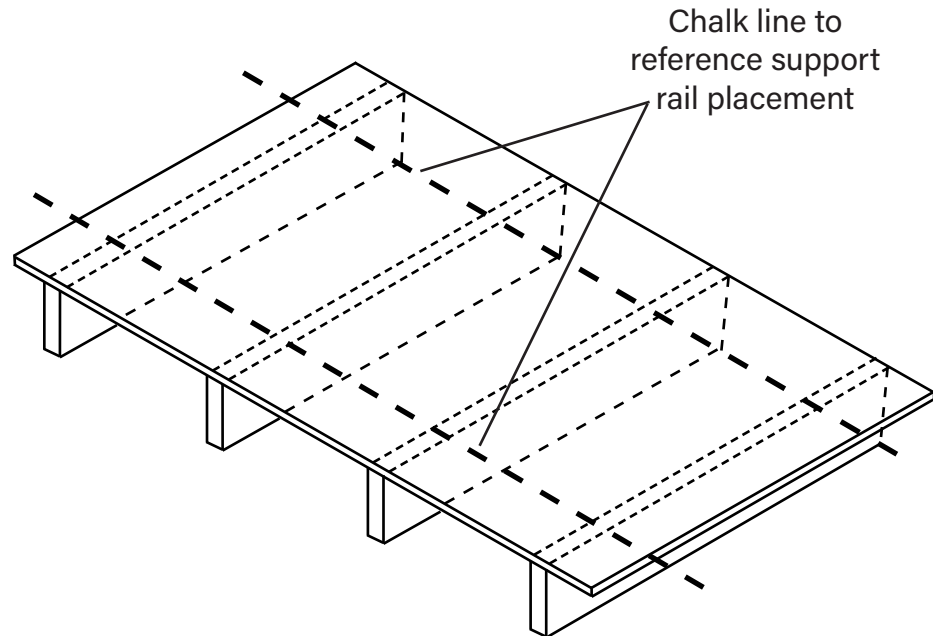

ProSolar® does not recommend 72" attachment spacing on residential structures, as residential structures are typically not designed for longer spans. It is highly recommended to obtain proper structural engineering for loading of the structure before specifying a long-span mounting system.

Proper Module/Rail Orientation- Single Array Sample

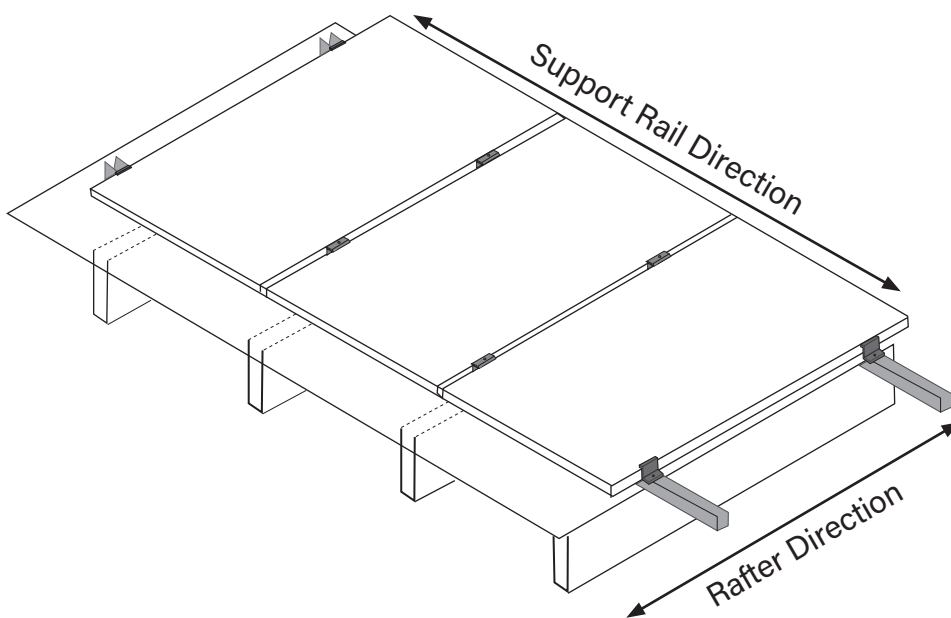

Locating Structural Members Along Chalk Lines

Finding initial reference support member for a commercial flat roof:

- 1) Locating commercial roof landmarks is usually sufficient for finding the initial reference support member. Landmarks include skylights, vents, and air conditioning units, as these are normally beside known structural members.
- 2) Upon identifying the general location of the support member, use a precision stud sensor to locate the center of the support member.
- 3) Once the initial reference support member center location is identified, measure the appropriate distance to help approximate the next support member/connection location.



Depending on the thickness of the roofing material the stud sensor can accurately indicate the location of the support member, which significantly reduces location time.



In some structures, such as open warehouses, the landmarks, and structural members are visible from below, which helps make locating structural members from the roof easier.



Alternate method of finding structural members

Using a dead blow hammer, lightly tap perpendicular to the approximate structural member location until a solid sound is heard. The dead blow hammer impact directly above the structural member will emit a deeper sound.

Attaching SolarWedge Base and Post to Wooden Structure



STEP 1: Use carbide bit to drill pilot hole (1/4" diameter pilot hole for 3/8" fastener or 3/16" diameter pilot hole for 5/16" fastener.)



STEP 2: Apply a generous amount of roof sealant into pilot hole.



STEP 3: Using a cordless impact wrench, fasten lag bolt to rafter through SolarWedge® base until seated.



STEP 4: Thread post into base. Tighten with pliers.



STEP 5: Post ready for SolarWedge® assembly.

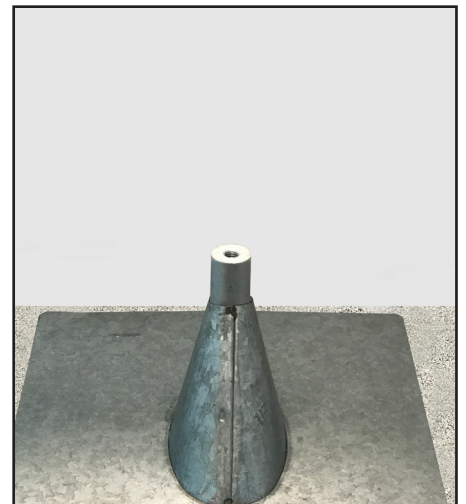

Post Compatible with Standard 3/4" (1" OD) Flashings



Lag bolts not included with SolarWedge® due to varying site-specific structural materials. Wood structure example shown above. Alternate fasteners can be used for different structural materials (ex: concrete, steel.) Consult your structural engineer for site specific fastener requirements.

Sealing with ChemLink E-Curb

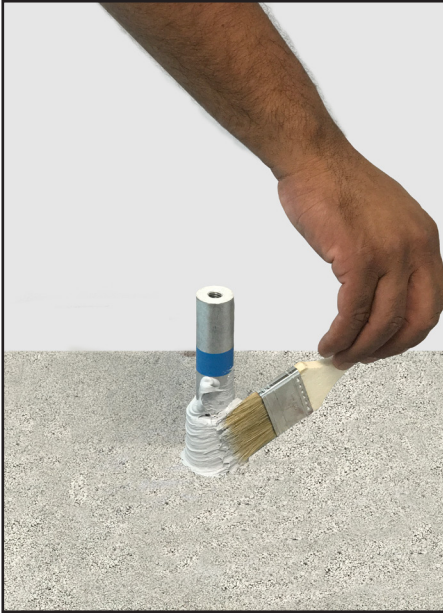

STEP 1: Apply M-1 Sealant to post. (Optional: Place painter's tape around post approximately 3" above roof.)



STEP 2: Apply M-1 Sealant to E-Curb, per ChemLink guidelines.



STEP 4: Adhere E-Curb to roof surface.



STEP 5: Fill E-Curb with 1-Part filler and remove tape.

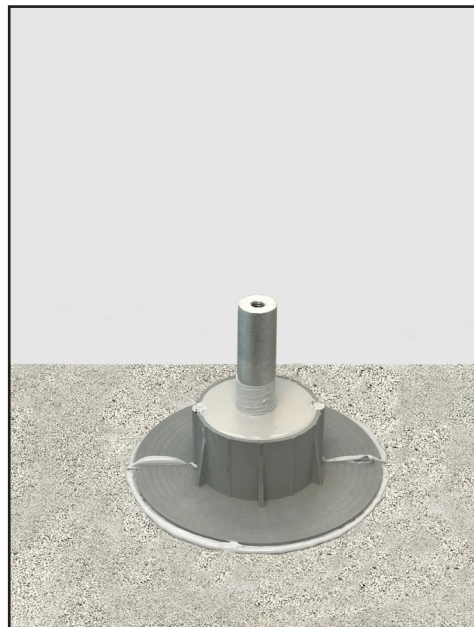

Completed E-Curb

Estimated Usage	
M-1 Sealant Tube (10.1 oz)	(1) Tube per (3) E-Curbs
1-Part Tube (10.1 oz)	(2) Tubes per (3) E-Curbs
1-Part Pouch (64 oz)	(1) Pouch per (10) E-Curbs

Attaching SolarWedge® Assembly

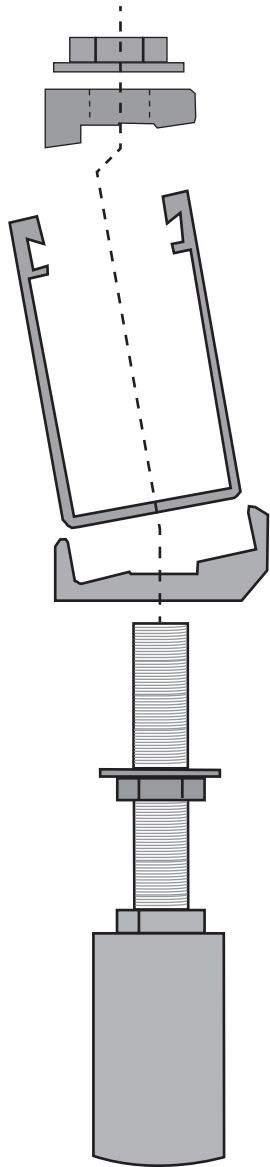

A

Level Support Rail

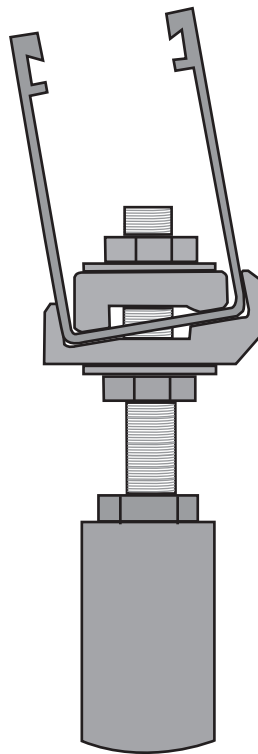

B

Hand-tighten 3/8" Jam
Nut/Washer

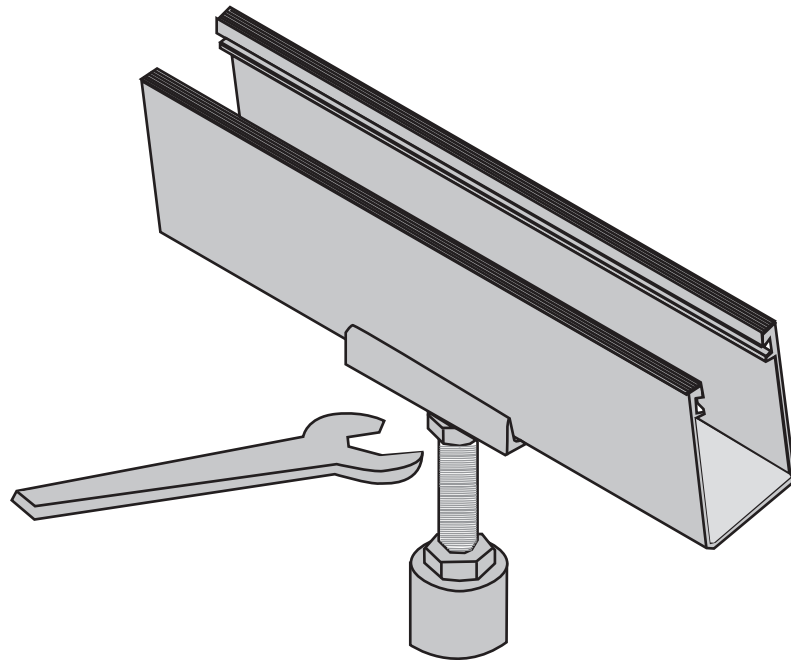

C

Using a 9/16" wrench, tighten the lower
jam nut turning counter-clockwise
(Approx. 10 ft lbs.) Repeat for all
attachment locations.

Post Dimensions

SolarWedge® Front & Rear Post Heights		
Angle	Front	Rear
1-Degree	5.25"	5.25"
5-Degree	5.25"	8.25"
10-Degree	5.25"	11.75"
15-Degree	5.25"	17"

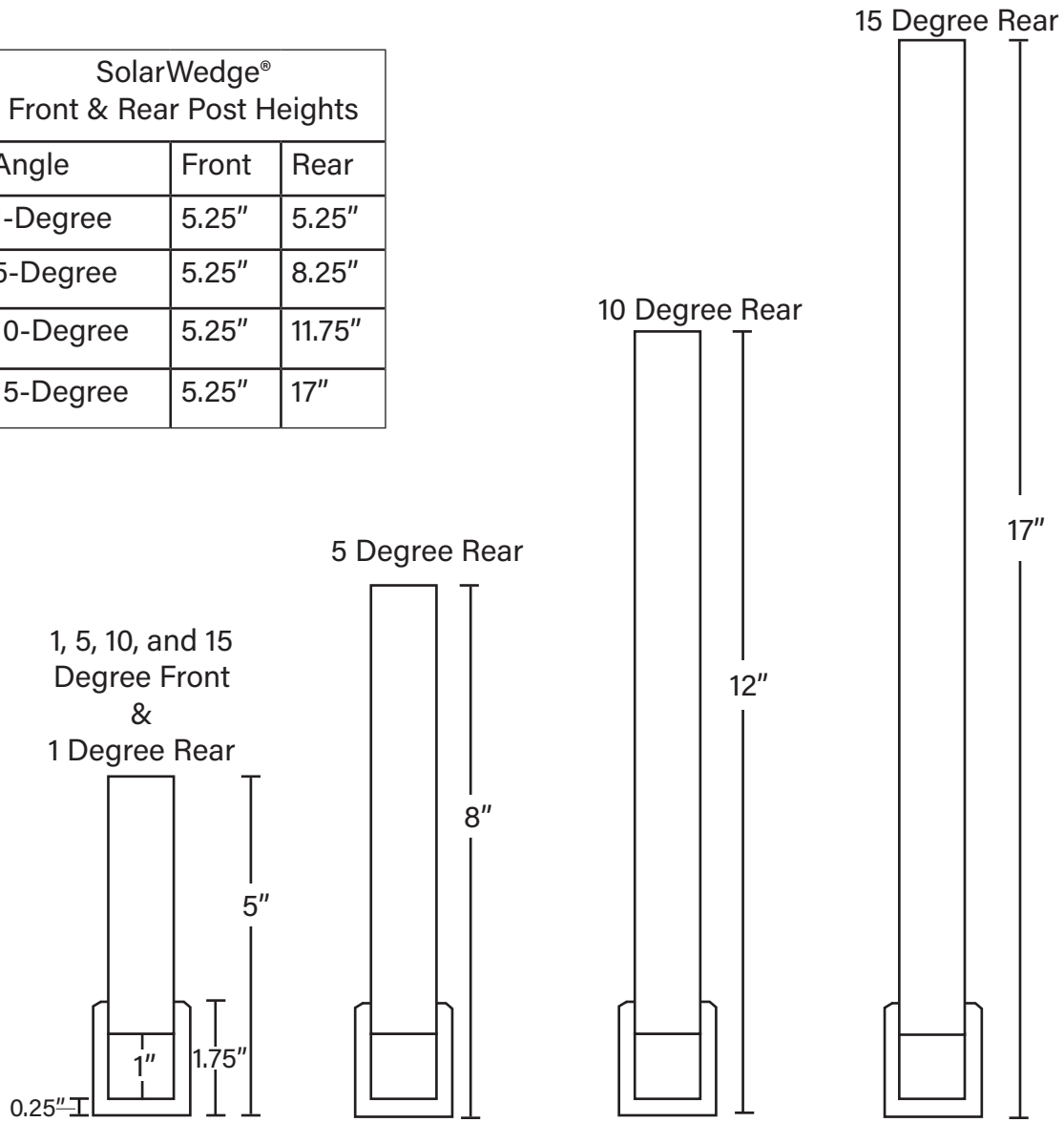

Fastening Rail to SolarWedge® Attachment

Use a Unibit®
3/4" #3 drill bit

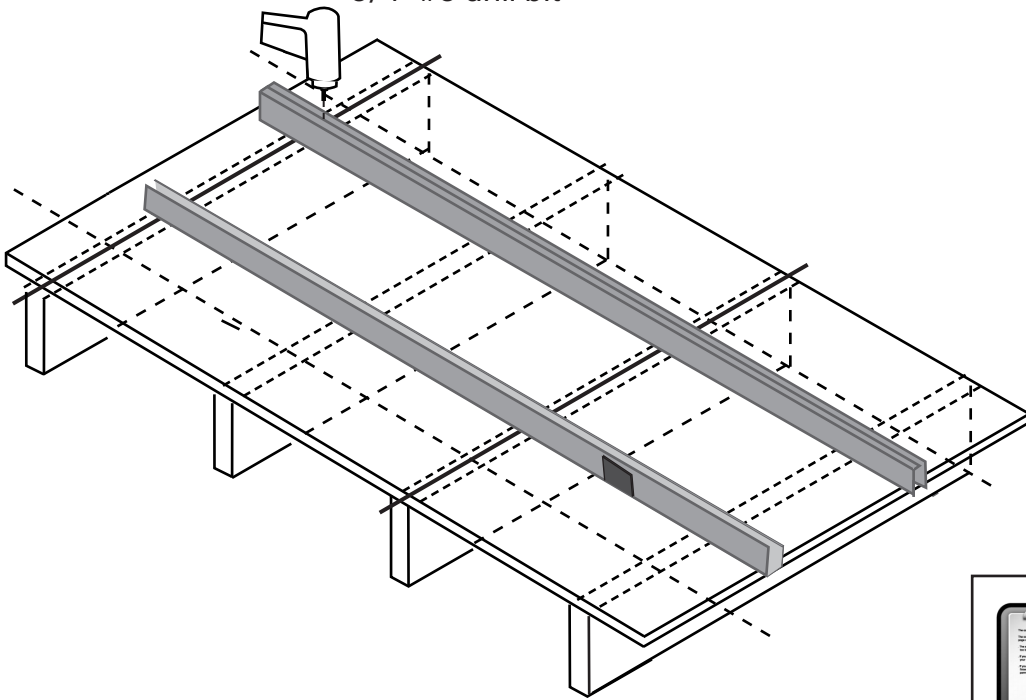

STEP 1: Using a string line from each end of the module array, level studs to desired position on roof (4" leveling stud must have at least 1" threaded into post).

STEP 2: Measure and mark hole placement on support rails—use a Sharpie® permanent marker to mark where drill holes should be placed.

STEP 3: Using the titanium plated 3/4" #3 self-starting Unibit® (sold separately) drill holes at stud centers along support rail.



Use a Unibit® 3/4" #3 titanium drill bit for drilling the support rail reduces drill time to only 3 seconds.

Use the SolarWedge® EZ Rail Lock tool to easily lock rails in place for proper hole drilling alignment .

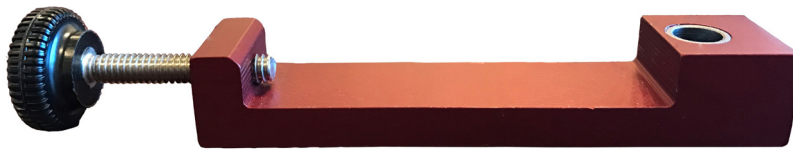

Bonding and Grounding (Patent Pending)

Assembled
Self-bonding
Mid Clamp With
SS Bus Bar

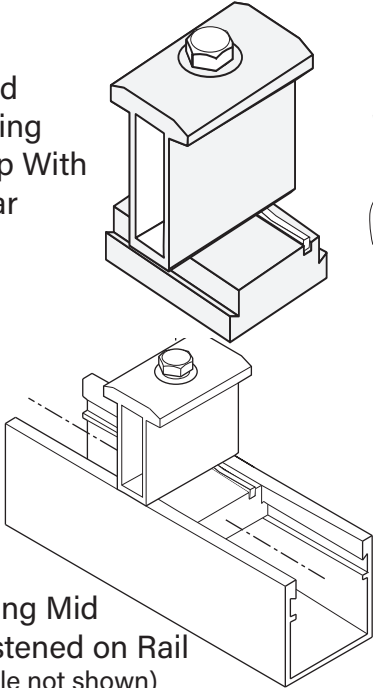

Self-bonding Mid
Clamp Fastened on Rail
(Solar Module not shown)

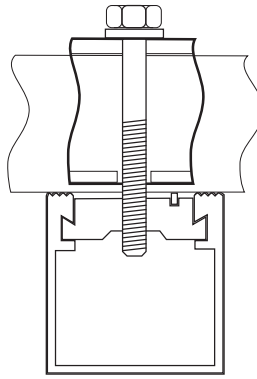

Side view of
Grounding

For bonding module frame and clamps to support rail

- Fasten pre-assembled mid-clamp assembly to module frame, to 15 ft-lbs.

Grounding of module to RoofTrac® rail via ProSolar® rail channel nut using bus bar.

Bonding of RoofTrac® rail to RoofTrac® rail via ProSolar® UL467 tested universal splice kit (splice insert and splice support).

Grounding of RoofTrac® rail or module via IlSCO SGB-4 lug.

System to be grounded per National Electrical Code (NEC), ANSI/NFPA 70. Grounding conductor shall be solid copper wire, 8 AWG minimum. See NEC and/or Authority Having Jurisdiction (AHJ) for site-specific grounding requirements prior to installation. See final run (racking to ground electrode) grounding equipment installation instructions for specific installation information.

Grounding Wire Installation

FOR GROUNDING CONNECTION

- ILSCO SGB-4 rail ground connection
- Fasten both terminals to 35 in-lbs
- Ensure that copper wire does not touch aluminum; Recommended 1/4" clearance.

Burndy Cable Clips

Outdoor rated, insulated wire, such as quick connect cables, can be nested inside the RoofTrac® support rail or held in place with approved cable clip such as Wiley ACC-R2 (for Microinverter trunk cable) and ACC-R4 (for PV wire) clips.

Uninsulated copper grounding wire must never be placed inside the aluminum rail – it should be kept at a distance of at least 1/4" away from the aluminum rail.

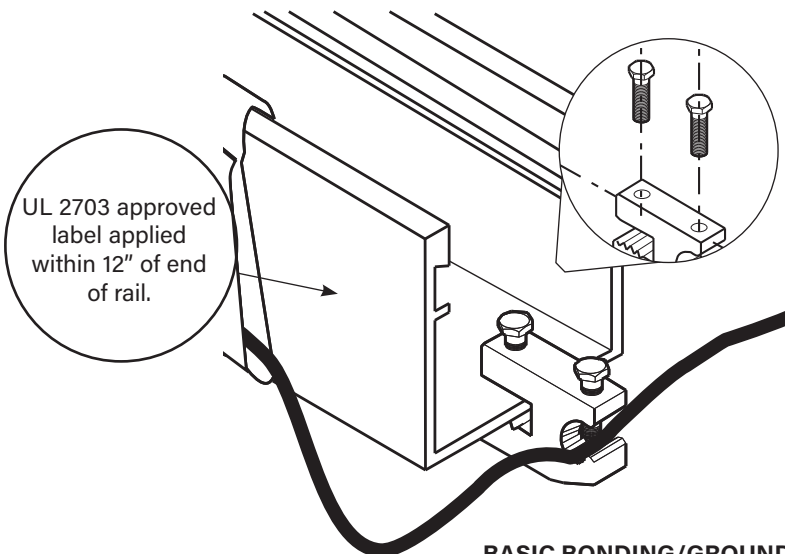

BASIC BONDING/GROUNDING CONNECTION DIAGRAM

Page 9 of 11

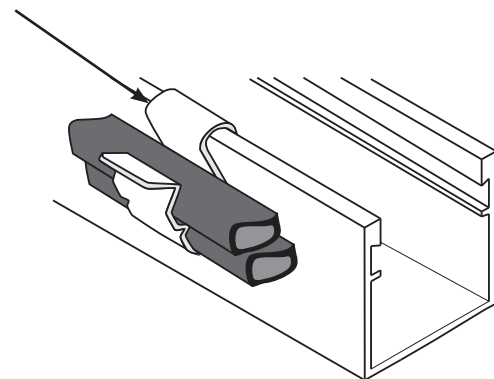

Microinverter and Optimizer (Self-Bonding Connector)

FOR GROUNDING USING ENPHASE ENGAGE CABLE

- No copper wire or lug required. Equipment grounding conductor (EGC) built into Enphase engage quick-connect cabling.
- Minimum of 2 microinverters to same Enphase engage trunk cable within continuous module row
- Modules in module row must be installed and grounded per install guide requirements and must share the same two rails.

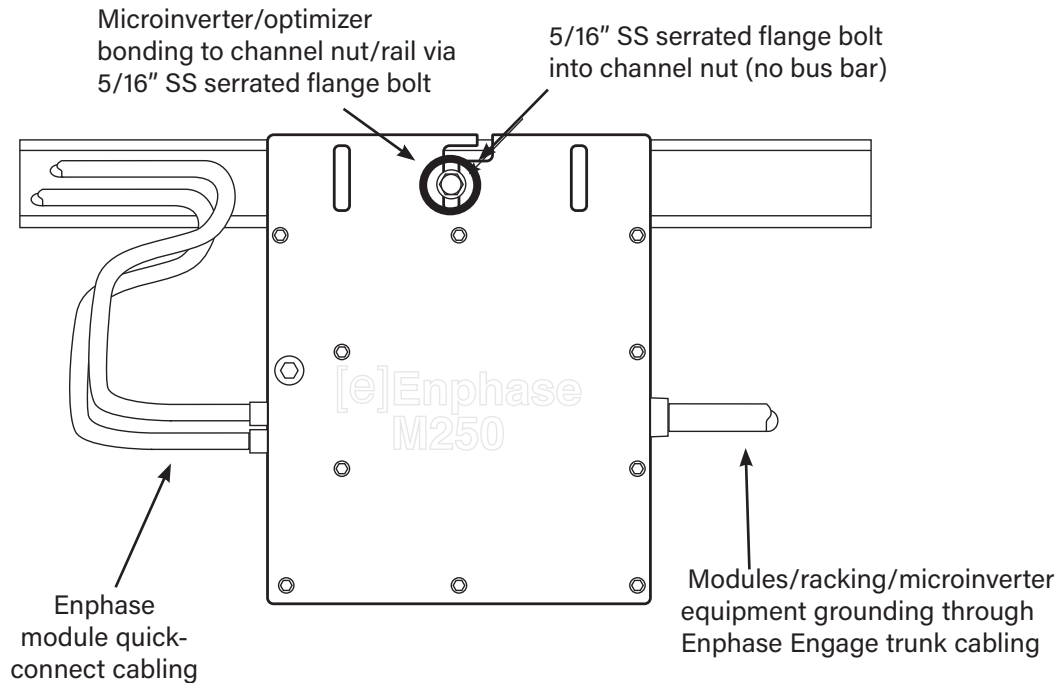

BASIC BONDING/GROUNDING CONNECTION DIAGRAM

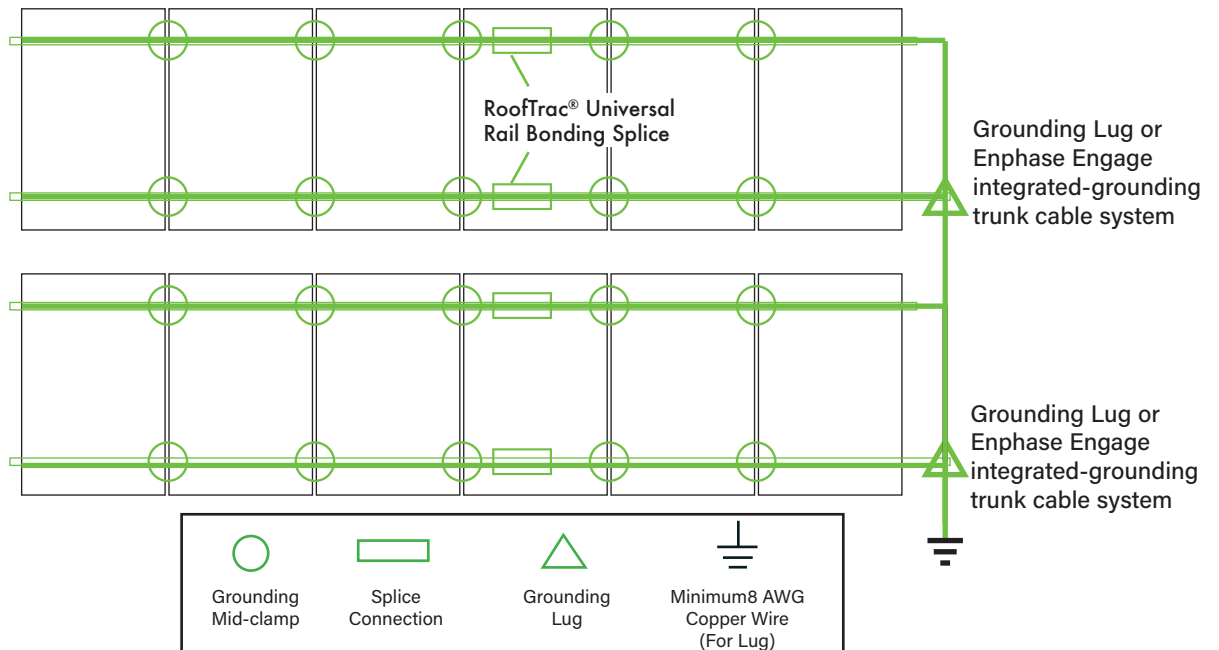

Installation of the clamping hardware/modules

There are two sets of clamps: the end clamps, which rest on the outside of the modules, and the pre-assembled mid clamps, which install between the modules.

Insert an end clamp at the end of each row of support rails. Hook the end clamps against the long end of the module and square off to the support rail. Tighten the clamps using a 1/2" box wrench or drive socket. **DO NOT OVERTIGHTEN.** ProSolar® recommends a maximum torque of 12-15 ft. lbs. to prevent damage to the module glass.

After the first module is secured, slide two mid clamp sets onto the first module or insert mid clamps using the RoofTrac® rail spreader tool. They are designed to remain captive in the rail, allowing the installer to slide and align the next module. Repeat this procedure until all modules are installed onto the support rails. Upon installation of the last module, install the module end clamps to complete the installation.

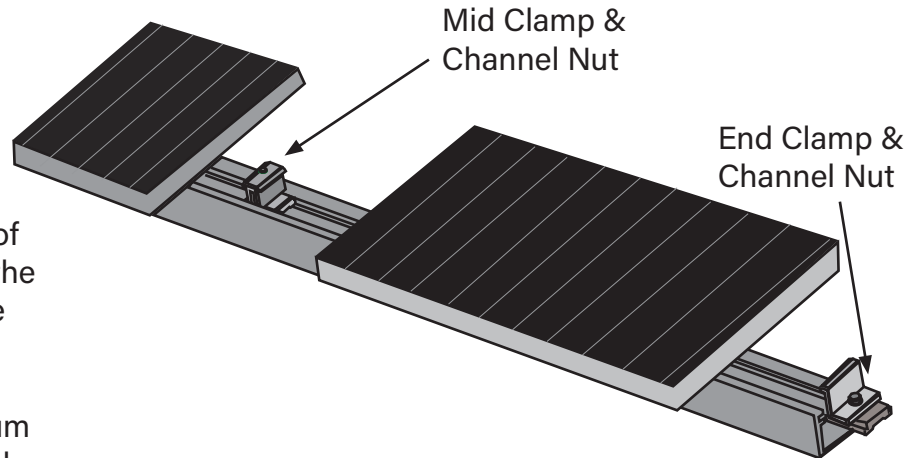

Hands-free clamp design allows both hands to be used to position modules while clamps remain captive in the support rail.

Clean up / Quality Inspection

Clean Up:

Upon completing the attachment installation, account for all tools and clean area as necessary.

Quality Inspection:

It is recommended that each contractor perform a final attachment quality inspection to ensure all attachments are properly fastened.



Make sure all installation crew members on the roof are mindful of installed roof attachments to prevent tripping. All installation crew members should utilize proper safety equipment when installing this mounting system. (Harnesses, hard-hats, gloves, proper no-slip footwear, etc.)