

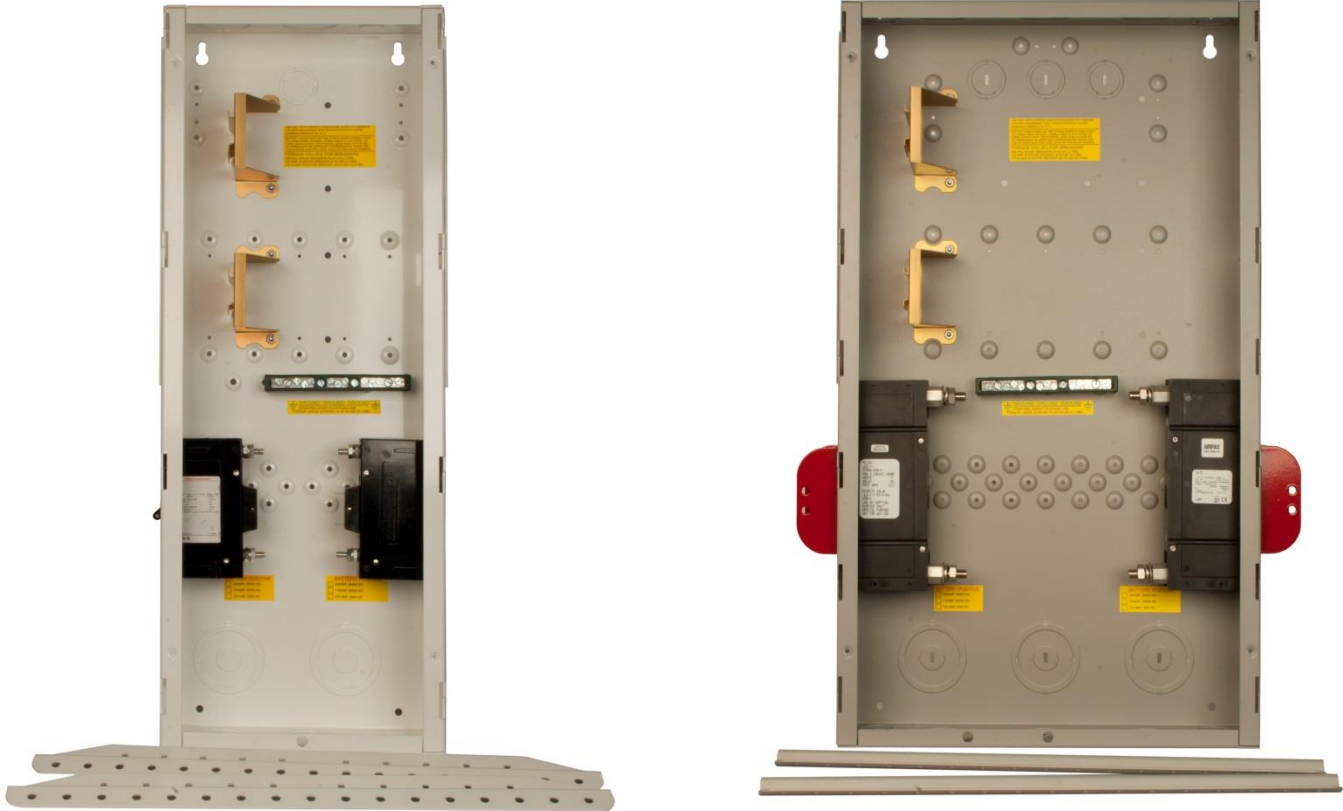

# MNDC-X2 INSTRUCTIONS

Models: MNDC125-X2, MNDC175-X2, MNDC250-X2



The MNDC125-X2 Based on our Narrow E-Panel chassis and MNDC175-X2 and MNDC250-X2 based on our wide E-Panel chassis with a blank door the MNDC-X2 comes with a pair of 125, 175 or 250 amp dc breakers( by model) and the earth ground buss bar. It has locations for 10 din rail breakers, 3 panel mount breakers, DC shunt as well as long and short terminal buss bars.

The MINI DC 125 X2 Disconnect is a white powder coated aluminum enclosure while the MINI DC 175 X2 and the 250 X2 are powder coated gray steel. They all come with two 125, 175 or 250 amp battery breakers (By model). The MNDC X2 accepts an additional 5 din rail breakers or 3 panel mount breakers. The boxes all come with grounding busbars and space to mount a 500 amp shunt.

## Features:

- Hinged door for easy access to electrical circuits
- Inverter breakers included (125, 175 or 250 amp)
- Din rails for DC circuits such as PV in, Chg Cntrl out, DC-GFP, DC loads, PV combiner
- Ground bus bar with 14 poles
- Mounting spots for 500 amp, 50mV shunt
- Mounting spot for insulated bus bars (for PV negative connection point)
- Knock outs for inverter and battery cables, charge control mounting, DC & PV in & out

# IMPORTANT SAFETY INSTRUCTIONS

**SAVE THESE INSTRUCTIONS** - These instructions contain important safety and operating instructions for the MidNite Solar DC Disconnect models MNDC125-X2, MNDC175-X2 and MNDC250-X2 for residential and commercial applications.

If you do not fully understand any of the concepts, terminology, or hazards outlined in these instructions, please refer installation to a qualified dealer, electrician or installer. These instructions are not meant to be a complete explanation of a renewable energy system.

### GENERAL PRECAUTIONS

**WORKING WITH OR IN THE VICINITY OF A LEAD ACID BATTERY, SEALED OR VENTED IS DANGEROUS. VENTED BATTERIES GENERATE EXPLOSIVE GASES DURING NORMAL OPERATION. FOR THIS REASON, IT IS VERY IMPORTANT THAT BEFORE SERVICING EQUIPMENT IN THE VICINITY OF LEAD-ACID BATTERIES, YOU REVIEW AND FOLLOW THESE INSTRUCTIONS CAREFULLY.**

If service or repair should become necessary, contact MidNite solar Inc. Improper servicing may result in a risk of shock, fire or explosion. To reduce these risks, disconnect all wiring before attempting any maintenance or cleaning. Turning off the inverter will not reduce these risks. Solar modules produce power when exposed to light. When it is not possible to disconnect the power coming from the Photovoltaics by an external means such as a combiner, cover the modules with an opaque material before servicing any connected equipment.

Never attempt to charge a frozen battery.

When it is necessary to remove a battery, make sure that the battery bank disconnect breaker is in the off position and that the PV breakers, grid breakers and any other sources of power to the inverter are in the off position. Then remove the negative terminal from the battery first.

To reduce risk of battery explosion follow these instructions and those published by the battery manufacturer as well as the manufacturer of any additional equipment used in the vicinity of the batteries. Before installing the battery enclosure, read all instructions and cautionary markings in or on any connected electrical equipment.

Avoid producing sparks in the vicinity of the batteries when using vented batteries. Provide ventilation to clear the area of explosive gases. Sealed AGM and Gel batteries do not under normal conditions create explosive gases. Be especially cautious when using metal tools. Dropping a metal tool onto batteries can short circuit them. The resulting spark can lead to personal injury or damage to the equipment. Provide ventilation to outdoors from the battery compartment when installing vented batteries such as golf cart T-105 batteries. The addition of a spill tray is also a good idea.

Clean all battery terminals. Very high currents are drawn from the batteries; even a small amount of electrical resistance can result in overheating, poor performance, premature failure or even fire.

Have plenty of fresh water and soap nearby in case battery acid contacts skin, clothing or eyes. Wear complete eye and clothing protection. Always avoid touching eyes while working near batteries. If battery acid or battery terminal corrosion contacts skin or clothing, wash immediately with soap and water. If acid enters the eyes, immediately flood with cool running water for at least 15 minutes and get medical attention immediately. Baking soda neutralizes battery acid electrolyte. Keep a supply near the batteries.

Do not work alone. Someone should be in the range of your voice or close enough to come to your aid when you work with or near electrical equipment.

Remove rings, bracelets, necklaces, watches etc. when working with batteries, photovoltaic modules or other electrical equipment. Power from an illuminated photovoltaic array makes a very effective arc welder with dire consequences if one of the welded pieces is on your person.

To reduce the risk of injury, connect only deep cycle lead acid type rechargeable batteries. Other types of batteries may leak or burst, causing personal injury or damage.

## MNDC-X2 Instructions (continued)

---

### Mounting the MNDC-X2:

The installation begins by selecting a wall. The MNDC-X2 is an indoor type 1 enclosure and should not be placed outside unless precautions are made to keep rain and moisture off of the system.

The installation must provide adequate clearance to operate the breakers. Ensure 30" clear on the wall. The MNDC-X2 may be located anywhere within this 30 inches, however make sure you have sufficient room to the side to operate the circuit breakers. Some MNDC-X2 installations may have circuit breakers on both sides.

The NEC requires 36 inches free and clear of obstructions in front of Electrical panels. The 36" clear area in front of all electrical panels is to provide a space to fall back into incase of electrical shock.

The MNDC-X2 is not extremely heavy but still requires an adequate mounting surface. The mounting brackets provided will span studs on 16 inch centers.

- 1.) Start two of the included taptite screws into one of the mounting brackets. Tighten most of the way but leave them loose enough to allow the chassis to slide onto them. Align the screws with the keyhole openings at the top of the MNDC-X2.
- 2.) Mount the top bracket as shown at about 64-68 inches off the floor. If stacking two systems vertically, make sure the breakers fall within the NEC guidelines for height, (lowest and highest allowable). Number 10 screws with back up washers will suffice, but ¼" (6mm) hardware provides for a better margin of safety.



Measuring and marking before mounting the MNDC-X2 to the wall.

- 3.) Mount the lower mounting bracket to on the rear at the bottom of the MNDC-X2 using the other two included taptite screws.
- 4.) Place the MNDC-X2 onto the top mounting bracket on the wall and tighten the screws.
- 5.) Screw the lower bracket into the wall studs or wall anchors.

Continue on to wiring.

## MNDC-X2 Instructions (continued)

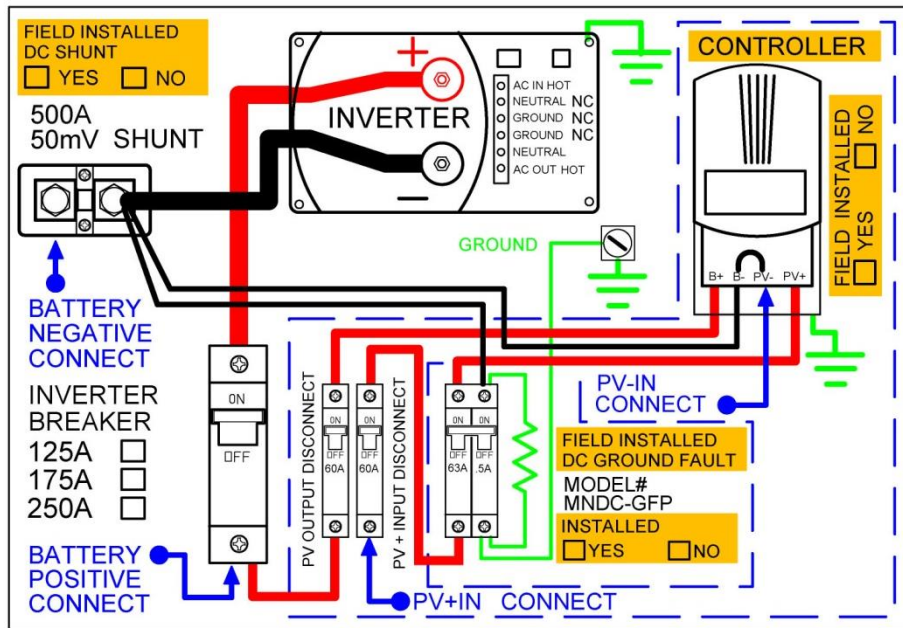

Wiring diagram

### Grounding

There are various ground circuits that need to be considered in the renewable energy system. The MNDC-X2 chassis should be grounded to your earth ground rod through a 6AWG wire connected to the ground bus bar located in the top left section of the MNDC-X2 chassis. The MNDC-X2 ground bus bar will then become your primary system DC ground. The ground bus bar is also where DC surge suppressors like the MNSPD get grounded. It is advisable to use one of the ½" conduit knockouts to mount a DC lightning arrestor to the MNDC-X2 box. It is also common to have a DC lightning arrestor out at the PV Panels that are grounded through their own ground rod. In dry climates it is advisable to also run a ground wire from the PV panels to the MNDC-X2 ground. The MNDC-X2 ground bus bar is an ideal place to ground a DC-GFP when installed as well as the inverter chassis and the charge control chassis. Do the grounds first since they normally lie in the bottom of the chassis.

### Battery Negative connection

The wiring diagram shows an optional 500 amp shunt. The voltage drop across the shunt is used to aid in calculating battery state of charge. The shunt does not ground the battery negative circuit. Grounding the battery negative is not allowed when employing a DC-GFP device.

### Battery Positive connections

DC positive from the battery bank connects to the lower section of the large DC inverter breaker. The lower inverter breaker stud is also the common point for connection of additional DC circuits such as from the output of a charge controller. Do not connect other charging sources to the top of the inverter breaker as this would apply power to the inverter even when the inverter breaker is turned off. The top section of the inverter breaker connects to the inverter positive battery terminal post. The photo on page 6 shows the inverter breaker wired with an additional charging source connected to the bottom section of the breaker.

Battery status monitor systems such as the Trimetric, E-Meter, and Trace Meter etc are available with or without the 500 amp 50mV shunt. The MNDC-X2 does not come with this shunt, so you will need to order the shunt.

# MNDC-X2 Instructions (continued)

**Optional Accessory:** Whiz Bang Jr. The Whiz Bang Jr is a current sense module that attaches to the standard 50mv / 500A Shunt (Sold separately) and wires into the Classic or KID Charge controllers to give Amperage readings from the shunt. This allows for EndAmps to function based on System amps or Classic amps and more. Refer to the documentation that came with the Whiz Bang Jr or visit us online at [www.midnitesolar.com](http://www.midnitesolar.com) for more information.

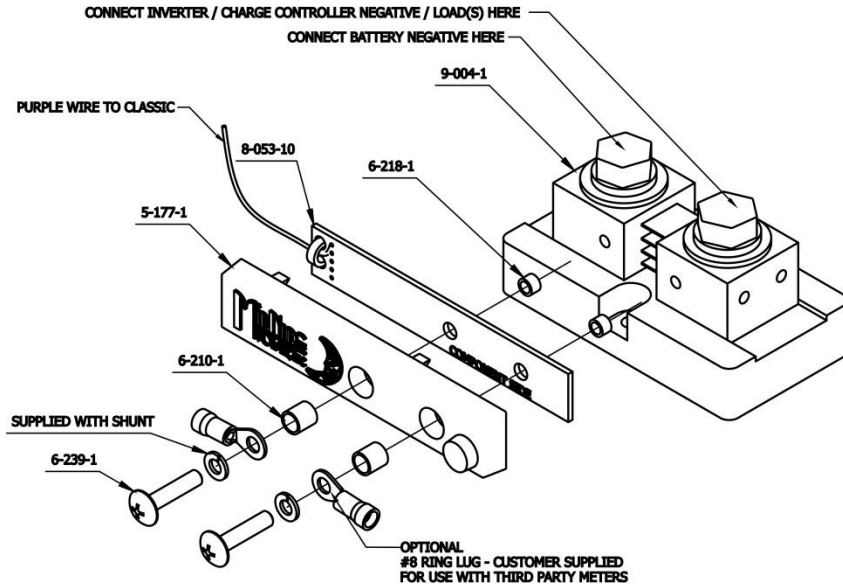

WBJR. Info

## DC Breakers and Cover

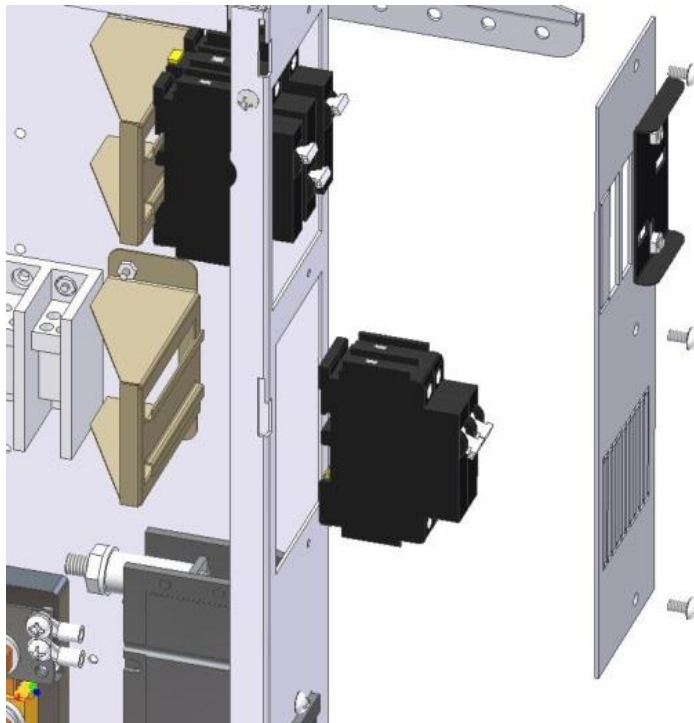

Remove the DC breaker cover to install din rail mount breakers. Insure the yellow tab snaps into place to secure the breakers. Strip wires 3/8" and bend at 3/4" from end. This section is very tight so pay close attention to wire routing. Use cable ties to secure wires in a neatly routed bundle. Lay the cover plate on a flat scrap wood surface and using a flat screw driver blade and hammer cut the tabs.

## MNDC-X2 Instructions (continued)

	MNDC125-X2	MNDC175-X2	MNDC250-X2
Enclosure rating	Indoor	Indoor	Indoor
Enclosure material	MNDC125-X2 Powder coated aluminum	MNDC175-X2 Gray steel powder coated	MNDC250-X2 Gray steel powder coated
Main breaker size in amps	Two 125 Amp Breakers	Two 175 Amp Breakers	Two 250 Amp Breakers
Additional overcurrent spaces and breaker part numbers	10 din rail MNEPV breakers and 3 panel mount	10 din rail MNEPV breakers and 3 panel mount	10 din rail MNEPV breakers and 3 panel mount
Ground busbar included	YES	YES	YES
Mounting location for 500 amp shunt	YES	YES	YES
Mounting location for long terminal busbar	YES	YES	YES
Listing	UL1741	UL1741	UL1741

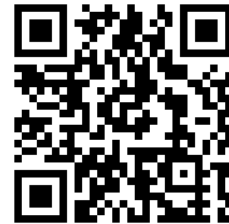

**MNSPD** Surge Protective Device

### Are you protected from surges?

The MidNite Solar Surge Protector Device (MNSPD) is a Type 2 device per UL1449 rev3. It is designed for both AC and DC systems and provides protection to service panels, load centers or where the SPD is directly connected to the electronic device requiring protection.

Sold separately. But a really good idea.

# MNDC-X2 Instructions (continued)

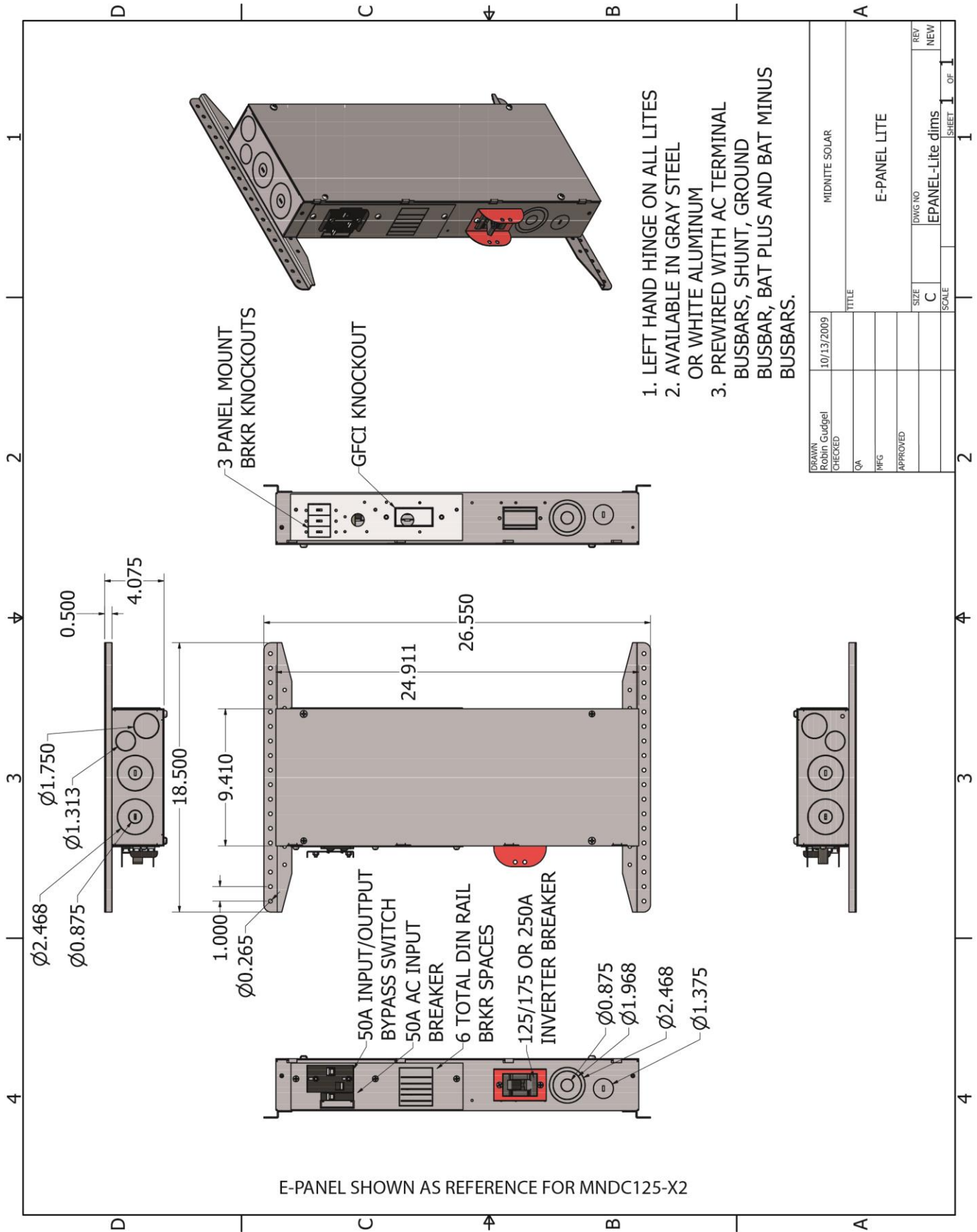

DRAWN Robbin Gudgeal CHECKED	10/13/2009	MIDNITE SOLAR	
QA		TITLE	
MFG		E-PANEL LITE	
APPROVED		SIZE	
	C	DWG NO	EPANEL-Lite dims
		SCALE	1 OF 1
		REV	NEW

# MNDC-X2 Instructions (continued)

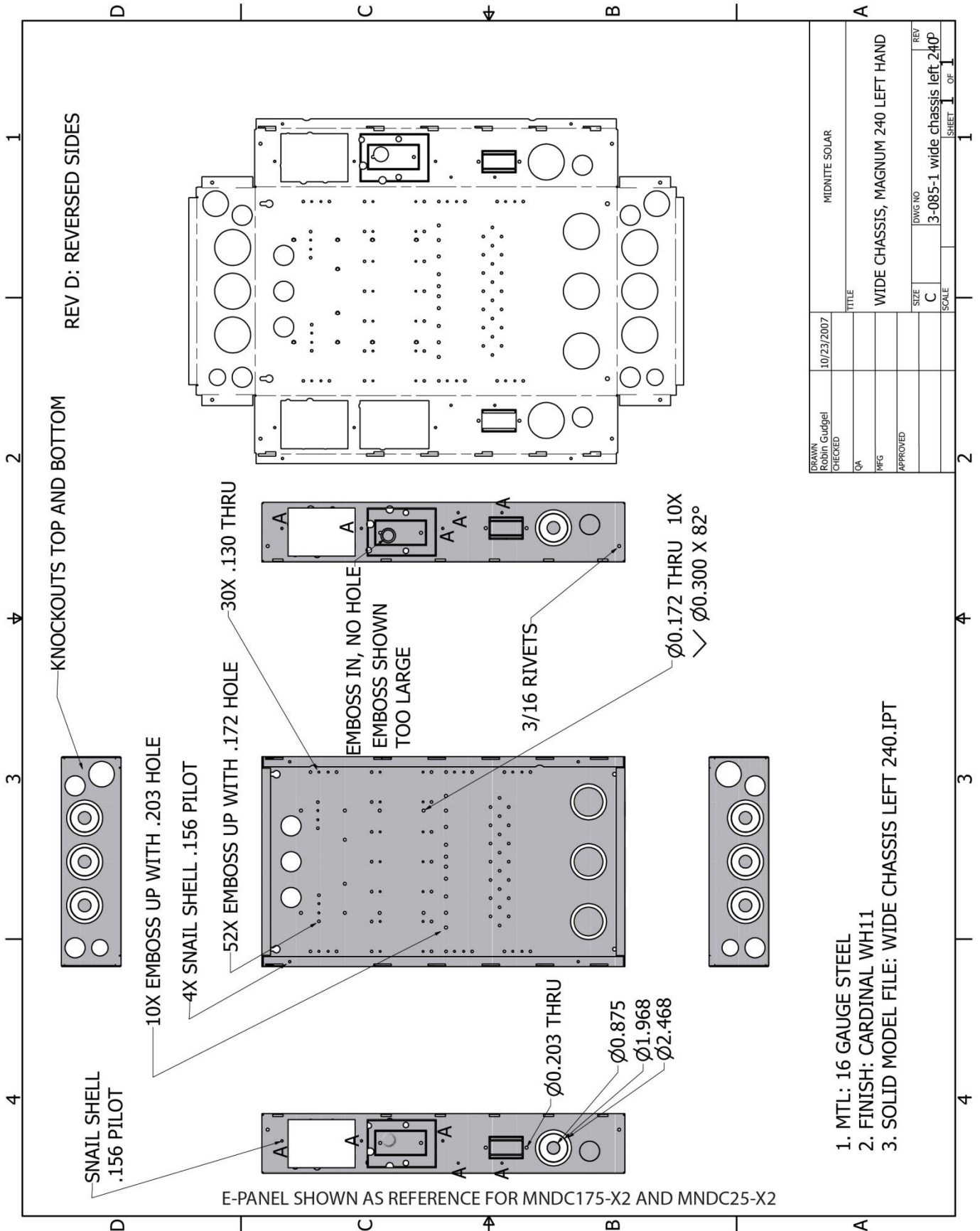



## MNDC-X2 Instructions (continued)

---

### **MIDNITE SOLAR INC. LIMITED WARRANTY** **MidNite Solar Power electronics, sheet metal enclosures and accessories**

MidNite Solar Inc. warrants to the original customer that its products shall be free from defects in materials and workmanship. This warranty will be valid for a period of five (5) years for all products except the MNKID Charge Controller which will be two (2) years.

At its option, MidNite Solar will repair or replace at no charge any MidNite product that proves to be defective within such warranty period. This warranty shall not apply if the MidNite Solar product has been damaged by unreasonable use, accident, negligence, service or modification by anyone other than MidNite Solar, or by any other causes unrelated to materials and workmanship. The original consumer purchaser must retain original purchase receipt for proof of purchase as a condition precedent to warranty coverage. To receive in-warranty service, the defective product must be received no later than two (2) weeks after the end of the warranty period. The product must be accompanied by proof of purchase and Return Authorization (RA) number issued by MidNite Solar. For an RMA number contact MidNite Solar Inc., 17722 67<sup>th</sup> Ave NE, Arlington, WA 98223 (360) 403-7207.

Purchasers must prepay all delivery costs or shipping charges to return any defective MidNite Solar product under this warranty policy. Except for the warranty that the products are made in accordance with, the specifications therefore supplied or agreed to by customer:

MIDNITE SOLAR MAKES NO WARRANTY EXPRESSED OR IMPLIED, AND ANY IMPLIED WARRANTY OF MERCHANTABILITY OR FITNESS FOR A PARTICULAR PURPOSE WHICH EXCEEDS THE FOREGOING WARRANTY IS HEREBY DISCLAIMED BY MIDNITE SOLAR AND EXCLUDED FROM ANY AGREEMENT MADE BY ACCEPTANCE OF ANY ORDER PURSUANT TO THIS QUOTATION. MIDNITE SOLAR WILL NOT BE LIABLE FOR ANY CONSEQUENTIAL DAMAGES, LOSS OR EXPENSE ARISING IN CONNECTION WITH THE USE OF OR THE INABILITY TO USE ITS GOODS FOR ANY PURPOSE WHATSOEVER. MIDNITE SOLAR'S MAXIMUM LIABILITY SHALL NOT IN ANY CASE EXCEED THE CONTRACT PRICE FOR THE GOODS CLAIMED TO BE DEFECTIVE OR UNSUITABLE.

Products will be considered accepted by customer unless written notice to the contrary is given to MidNite Solar within ten (10) days of such delivery to customer. MIDNITE SOLAR is not responsible for loss or damage to products owned by customer and located on MIDNITE SOLAR'S premises caused by fire or other casualties beyond MIDNITE SOLAR'S control. This warranty is in lieu of all other warranties expressed or implied.