

MGS 60M10

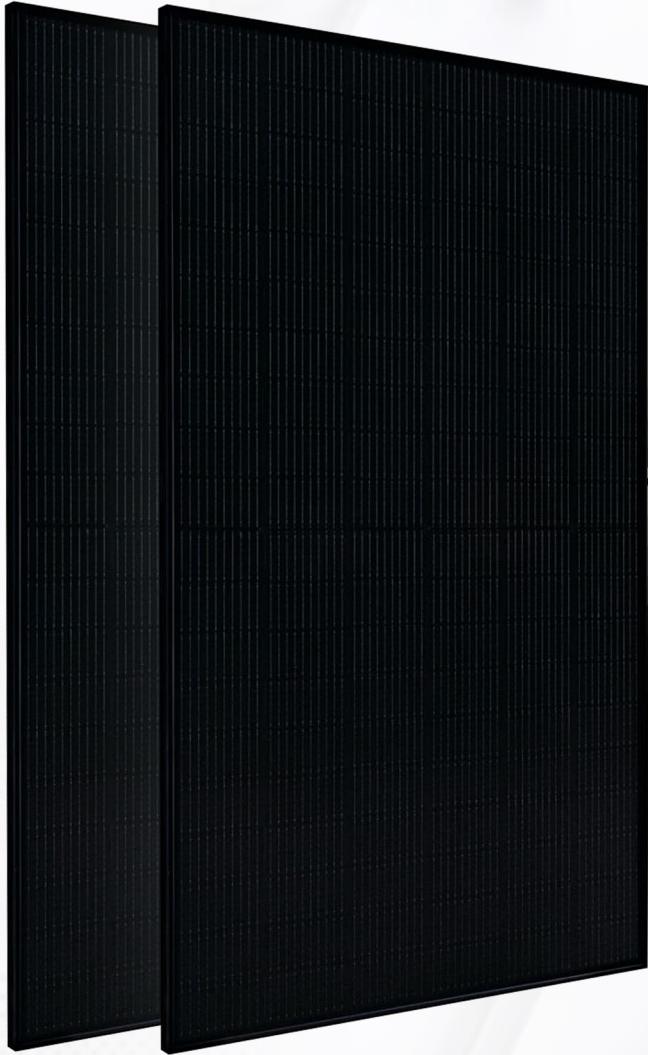

430-460W



Superior aesthetics, all-black design



Robust product design for harsh weather conditions



Improved performance in shaded areas



Designed & engineered in the U.S., Made in Dubai

Certifications:



Intertek



Headquarter address

📍 Magnus Green Solar LLC, 360 E 2nd St, STE 820
Los Angeles, CA 90012 USA

☎ +1-888-259-4196

✉ info@magnusgreensolar.com

Factory address

📍 National Industries Park, Plot TP010505,
Jebel Ali(South), Dubai, United Arab Emirates

☎ +971 50 786 3131

✉ info@magnusgreensolar.com

MECHANICAL SPECIFICATIONS

Cell Type	Mono 182x91mm
Weight	24kg
Dimension	1906x1134x35mm (LxWxT)
Cables	4.0mm ² , Portrait: 300mm(+)/400mm(-) Landscape: 1400mm(+)/1400mm(-)
No. of Cells	120 (6x20)
Glass	3.2mm High Transmission, Antireflection Coating
Junction Box	IP68, 3 Bypass Diodes
Packing	31pcs/pallet, 744pcs/40HQ
Connector Type	Staubli Electrical Connectors AG (PV-KST4-EVO2/XY_UR)

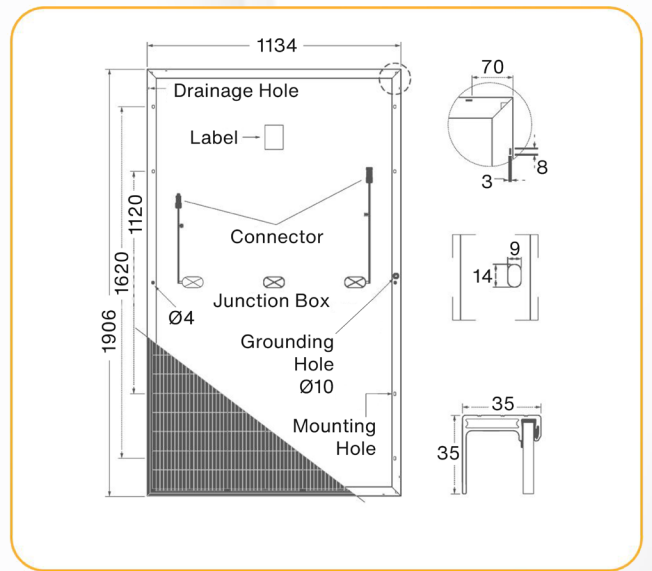

ELECTRICAL SPECIFICATIONS

Module Type	MGS 60M10-430W		MGS 60M10-435W		MGS 60M10-440W		MGS 60M10-445W		MGS 60M10-450W		MGS 60M10-455W		MGS 60M10-460W	
	STC	NOCT	STC	NOCT	STC	NOCT	STC	NOCT	STC	NOCT	STC	NOCT	STC	NOCT
Testing Condition														
Open-circuit Voltage (Voc/V)	40.8	38.3	41.00	38.5	41.02	38.6	41.10	38.8	41.18	39.0	41.8	39.2	42.0	39.4
Maximum Power Voltage (Vmp/V)	34.1	32.0	34.30	32.2	33.72	32.4	33.82	32.6	33.91	32.8	35.20	33.0	35.5	33.3
Short-circuit Current (Isc/A)	13.42	10.84	13.48	10.89	13.73	10.94	13.79	10.99	13.85	11.04	13.72	11.09	13.78	11.13
Maximum Power Current (Imp/A)	12.62	10.01	12.69	10.06	13.05	10.11	13.16	10.15	13.27	10.20	12.93	10.24	12.97	10.29
Maximum Power (Pmax/W)	430	320	435	324	440	327	445	331	450	335	455	339	460	342
Module Efficiency (%)	19.91%		20.14%		20.36%		20.59%		20.82%		21.06%		21.30%	
Power Tolerance													±3%	
Tolerance of Rating Pmax/Isc/Voc%													±3%/±4%/±3%	

NOCT: Irradiance 800w/m², Cell Temperature 20°C, Spectrum AM1.5, Wind Speed 1m/s STC: Irradiance 1000w/m², Cell Temperature 25°C, Spectrum AM1.5

Binning Tolerance: 0 to +5W

MAXIMUM RATINGS

Maximum System Voltage	1500V DC
Operating Temperature	-40°C to +85°C
Maximum Series Fuse	25A
Safety Class	II
Fire Rating	Class C
Mechanical Load	5400pa

TEMPERATURE CHARACTERISTICS

NOCT Temperature	45°C±2°C
Temperature Coefficient (Pmax)	-0.37%/°C
Temperature Coefficient (Voc)	-0.29%/°C
Temperature Coefficient (Isc)	0.05%/°C

PERFORMANCE WARRANTY

Max Power Degradation	0.5%/Year
97.5% At The End of 1 st Year	
93% At The End of 10 th Year	
85.5% At The End of 25 th Year	

CURVE & TEMPERATURE DEPENDENCE

