

GROUND MOUNT

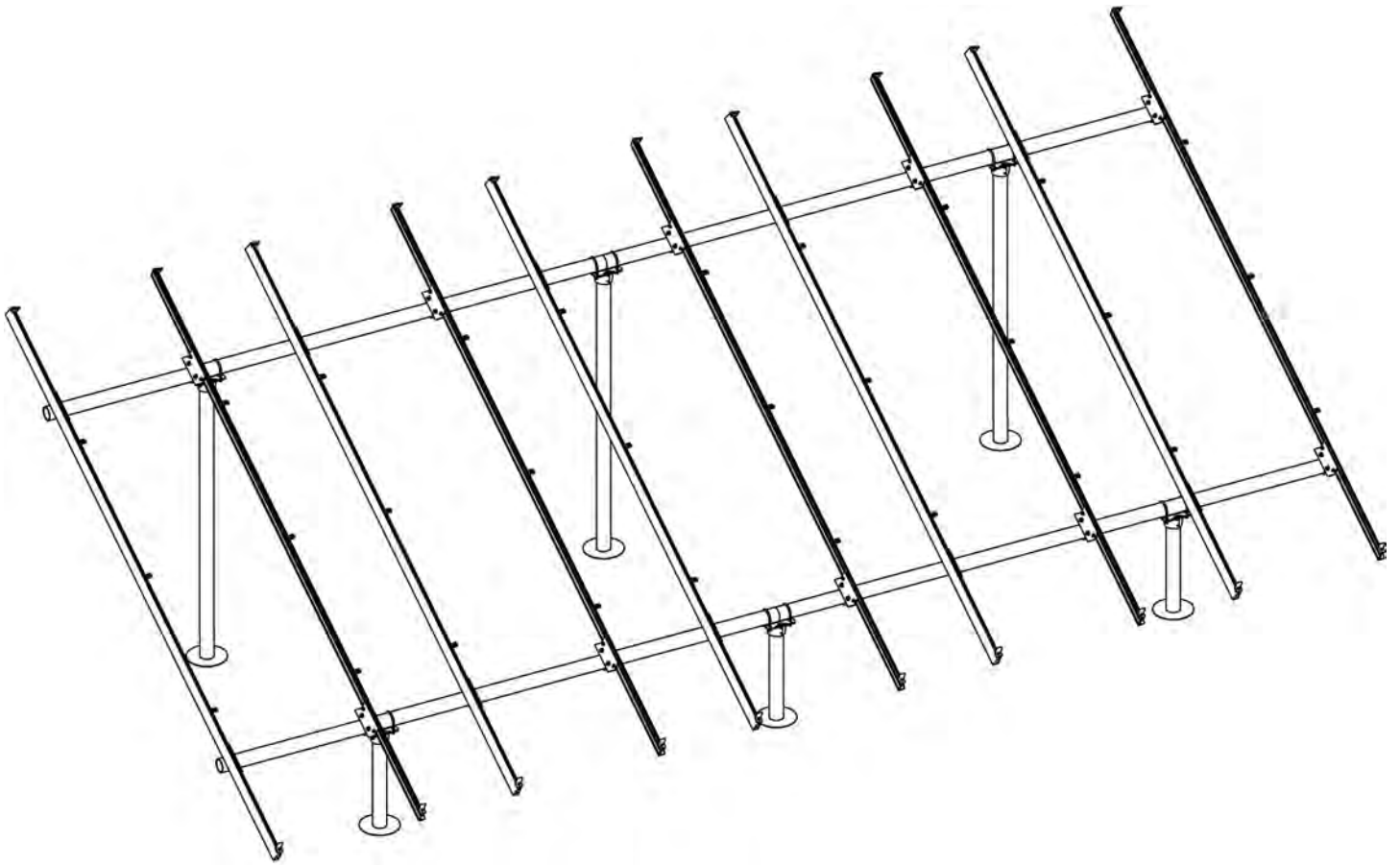

CONTENTS

DISCLAIMER	1
RATINGS	2
MARKINGS	2
CHECKLIST	3
1. BUILD BASE	4
1. BUILD BASE	5
2. CONNECT SUBSTRUCTURE	5
3. PLACE RAILS	6
4. SECURE LUGS	6
5. SECURE MODULES	7
CAMO	8
ELECTRICAL DIAGRAM	9
DIAGONAL BRACES (OPTIONAL)	10
END CAPS	10
WIRE CLIPS	10
SPLICING HORIZONTAL BEAMS	11
MICROINVERTER KITS	12
SYSTEMS USING ENPHASE MICROINVERTERS OR SUNPOWER AC MODULES	12
SYSTEMS USING MICROSTORAGE PRODUCTS	13
FRAMELESS MODULE KITS	13
MODULE COMPATIBILITY	14-18
FRAMLESS MODULE COMPATIBILITY	19

DISCLAIMER

This manual describes proper installation procedures and provides necessary standards required for product reliability. Warranty details are [available on website](#). All installers must thoroughly read this manual and have a clear understanding of the installation procedures prior to installation. Failure to follow these guidelines may result in property damage, bodily injury or even death.

IT IS THE INSTALLER'S RESPONSIBILITY TO:

- Ensure safe installation of all electrical aspects of the array. All electrical installation and procedures should be conducted by a licensed and bonded electrician or solar contractor. Routine maintenance of a module or panel shall not involve breaking or disturbing the bonding path of the system. All work must comply with national, state and local installation procedures, product and safety standards.
- Comply with all applicable local or national building and fire codes, including any that may supersede this manual.
- Ensure all products are appropriate for the installation, environment, and array under the site's loading conditions.
- Use only IronRidge parts or parts recommended by IronRidge; substituting parts may void any applicable warranty.
- Review the [Design Assistant](#) and [Certification Letters](#) to confirm design specifications.
- Ensure provided information is accurate. Issues resulting from inaccurate information are the installer's responsibility.
- Validate foundation parameters prior to installation, as a local geotechnical report may be required to assess ground conditions. We recommend consulting with a local engineer familiar with local regulations and build site requirements, including soil conditions, terrain and load criteria. All parameters may impact foundation requirements.
- Ensure bare copper grounding wire does not contact aluminum and zinc-plated steel components, to prevent risk of galvanic corrosion.
- If loose components or loose fasteners are found during periodic inspection, re-tighten immediately. If corrosion is found, replace affected components immediately.
- Provide an appropriate method of direct-to-earth grounding according to the latest edition of the National Electrical Code, including NEC 250: Grounding and Bonding, and NEC 690: Solar Photovoltaic Systems.
- Disconnect AC power before servicing or removing modules, AC modules, microinverters and power optimizers.
- Review module manufacturer's documentation for compatibility and compliance with warranty terms and conditions.

RATINGS

UL 2703 LISTED



#5003225
#5017912

Intertek

- Conforms to STD UL 2703 (2015) Standard for Safety First Edition: Mounting Systems, Mounting Devices, Clamping/Retention Devices, and Ground Lugs for Use with Flat-Plate Photovoltaic Modules and Panels.
- Certified to CSA STD LTR AE-001-2012 Photovoltaic Module Racking Systems.
- Max Overcurrent Protective Device (OCPD) Rating: 25A
- Max Module Size: 25.6 ft²
- Max Frameless Module Size for Canadian LTR-AE: 21.5 ft²
- CAMO Specific Allowable Design Load Rating: 50 PSF downward, 50 PSF upward, 15 PSF lateral
- LTR AE Canadian Load Rating: 2400 Pa
- System Level Allowable Design Load Rating: meets minimum requirements of the standard (10 PSF downward, 5 PSF upward, 5 PSF lateral). Actual system structural capacity is defined by PE stamped [certification letters](#).

CLASS A SYSTEM FIRE RATING PER UL 2703

- Not Fire Rated

STRUCTURAL CERTIFICATION

- Designed and Certified for Compliance with the International Building Code & ASCE/SEI-7

MARKINGS

Product markings are located on the system's Rail Connectors.

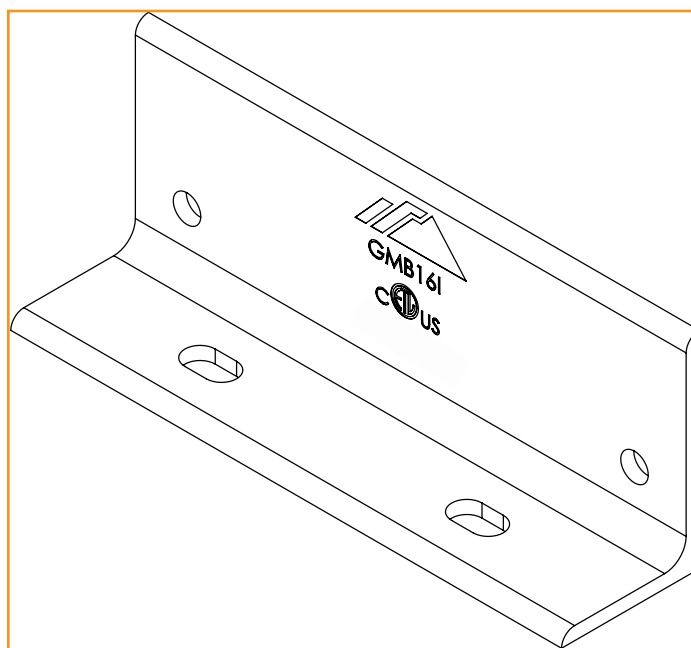

CHECKLIST

PRE-INSTALLATION

- Verify module compatibility. See [Page 14](#) for info.
- Purchase 2" or 3" Pipe or Mechanical Tubing

Pipe: 2" or 3" (NPS) ASTM A53 Grade B SCH 40 Pipe, galvanized to a min of ASTM A653 G90 or ASTM A123 G35.

Mechanical Tubing: 2.375" x 12 ga (O.D) or 3.500" x 8 ga (O.D.) Mechanical Tubing with one of the following Galvinizations (ASTM A1057).

- Allied Gatorshield
- Allied Flo-Coat Coating
- Wheatland ThunderCoat

TOOLS REQUIRED

- Post Hole Digger or Powered Auger
- Socket Drive (7/16", 9/16", and 1/2" Sockets)
- Torque Wrenches (0-240 in-lbs and 10-40 ft-lbs)
- Transit, String Line, or Laser Level
- 3/16" Allen Head

TORQUE VALUES

Top Cap Set Screws (3/16" Allen Head)

- 2" or 3" NPS Schedule 40 Grade B Pipe: 20 ft-lbs
- 2.375" x 12 ga OD Mechanical Tubing: 11 ft-lbs
- 3.500" x 8 ga OD Mechanical Tubing: 16 ft-lbs
- For Ground Screw to Pipe Connection Hardware see [Page 5](#).
- Top Cap U-Bolt Nuts (9/16" Socket): 15 ft-lbs
- Rail Connector Bracket Nuts (9/16" Socket): 21 ft-lbs
- Rail Connector U-Bolt Nuts (9/16" Socket): 60 in-lbs
- Rail Grounding Lug Nut (7/16" Socket): 80 in-lbs
 - Rail Grounding Lug Terminal Screws (7/16" Socket): 20 in-lbs
- Module Grounding Lug Nut (3/8" Socket): 60 in-lbs
 - Module Grounding Lug Terminal Screws (1/2" Socket): 20 in-lbs
- Universal Fastening Objects (7/16" Socket): 80 in-lbs
- Diagonal Brace Set Screws (1/2" Socket): 15 ft-lbs
- Diagonal Brace Bolts (1/2" Socket): 40 ft-lbs
- Microinverter Kit Nuts (7/16" Socket): 80 in-lbs
- Frameless Module Kit Nuts (7/16" Socket): 80 in-lbs
- If using previous version of: Integrated Grounding Mid Clamps, Grounding Lug and End Clamps please refer to Alternate Components Addendum (Version 1.70).
- If installing on a low slope roof please refer to Ground Mount for Flat Roof Applications Addendum (Version 2.70).

IRONRIDGE COMPONENTS

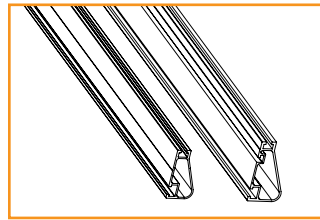

XR100 & XR1000 Rail

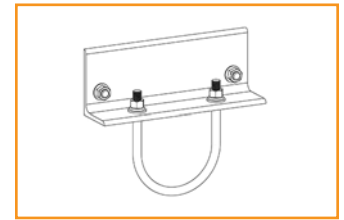

Rail Connector

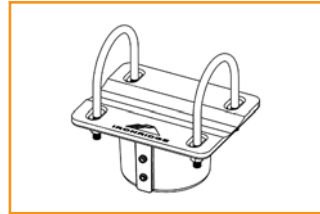

Top Cap

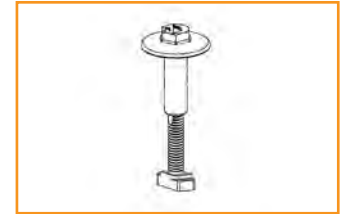

UFO

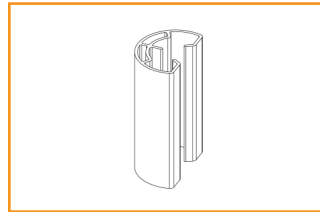

Stopper Sleeve



CAMO

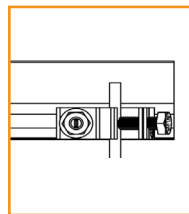

Rail Grounding Lug

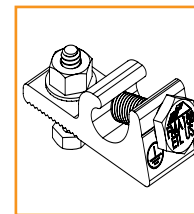

Module Grounding Lug

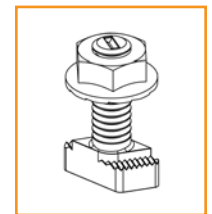

Microinverter Kit

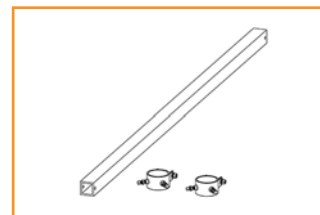

Diagonal Brace



End Cap



Wire Clip

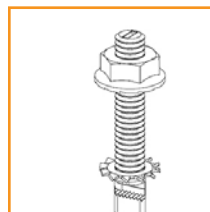

Frameless Module Kit

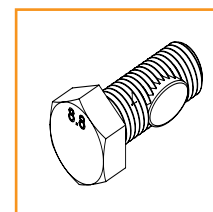

Hex Head Set Screw

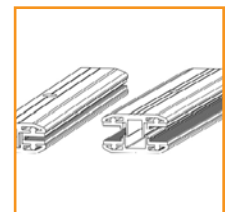

Frameless End/Mid Clamp

TESTED AND EVALUATED PIPE AND TUBE

Approved 2"	Approved 3"
MECHANICAL TUBE 12 GA <ul style="list-style-type: none"> 50 KSI YIELD STRENGTH GALVANIZED (ALLIED FLO-COAT, ALLIED GATORSHIELD OR WHEATLAND THUNDER COAT) <p>TOP CAP SET SCREW INSTALL TORQUE: 11-FTLBS</p>	MECHANICAL TUBE 8 GA <ul style="list-style-type: none"> 45 KSI YIELD STRENGTH GALVANIZED (ALLIED FLO-COAT, ALLIED GATORSHIELD OR WHEATLAND THUNDER COAT) <p>TOP CAP SET SCREW INSTALL TORQUE: 16-FTLBS</p>
SCHEDULE 40 GR B PIPE <ul style="list-style-type: none"> ASTM A53 GR B 35 KSI YIELD STRENGTH HOT DIPPED GALVANIZED <p>TOP CAP SET SCREW INSTALL TORQUE: 20-FTLBS</p>	SCHEDULE 40 GR B PIPE <ul style="list-style-type: none"> ASTM A53 GR B 35 KSI YIELD STRENGTH HOT DIPPED GALVANIZED <p>TOP CAP SET SCREW INSTALL TORQUE: 20-FTLBS</p>

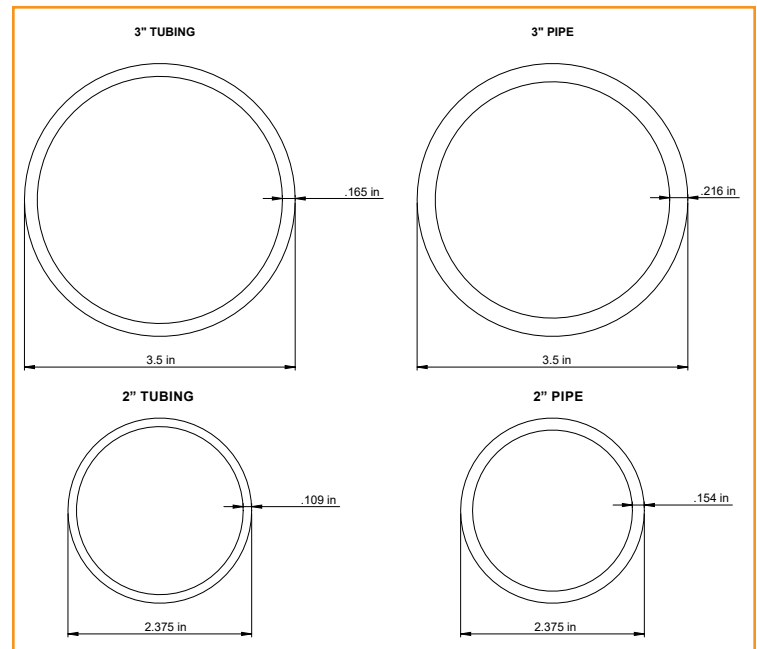

1. BUILD BASE

A. MARK LOCATIONS

Establish pier locations. Once grid of pier locations has been set, verify all angles are square.

- Spacing varies with load conditions. Consult engineering specs.

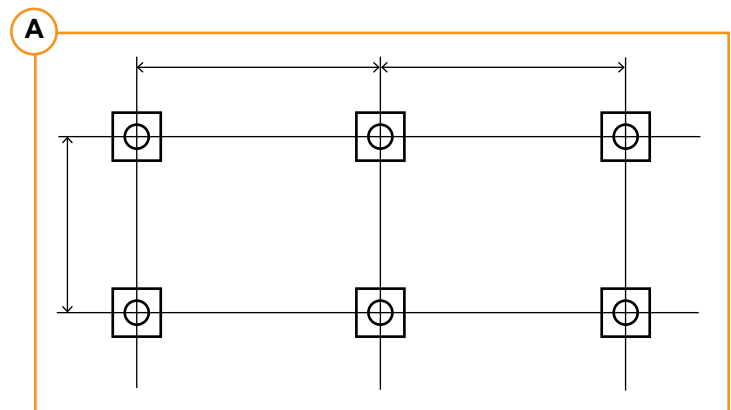

B. POSITION PIERS CONCRETE FOUNDATIONS

Excavate the foundation holes. Insert vertical piers into foundation holes, and pour in concrete mixture. Ensure vertical piers are plumb, level, square, and placed in parallel rows. Level the tops so they are even.

- Brace piers until concrete foundation has cured.
- In some cases, cross bracing is required to provide extra support for piers. If required, install [Diagonal Braces](#) at this time.

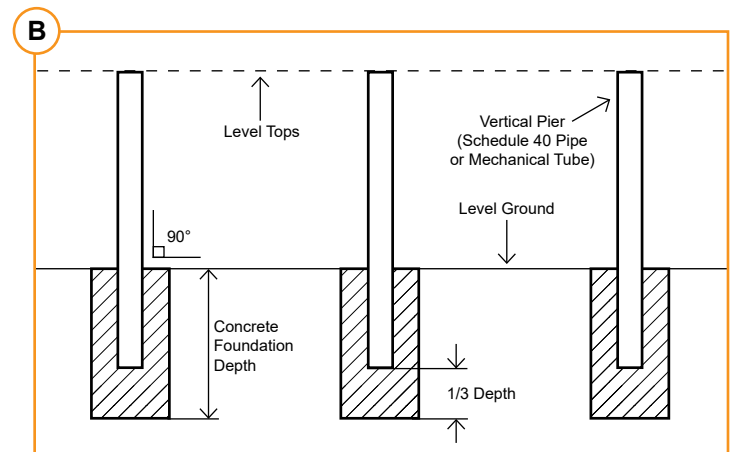

1. BUILD BASE (CONT.)

GROUND SCREW FOUNDATIONS

Follow respective Ground Screw Manufacturer's installation methods for driving screws into soil. Insert vertical piers into ground screws, ensuring at least 18" of pier is inserted into ground screw.

Tested and/or Evaluated Ground Screws

	2" System	3" System
Manufacturer Model #	American Ground Screw Model 3 76mm x 3(+)/mm	American Ground Screw Model 3 102mm x 3.75(+)/mm
	Krinner North America KSF G76	Krinner North America KSF G114
Set Screw Torque Specification	SCHD. 40: 90 ft-lb	SCHD. 40: 120 ft-lb
	Mech. Tubing: 75 ft-lb	Mech. Tubing: 90 ft-lb

- A minimum ground screw length of 1300mm must be used for either ground screw manufacturer. Longer lengths may be required in areas with high wind and snow loads or risk of freeze-thaw heaving. Check with your local jurisdiction for frost line embedment requirements.
- Hex Head Set Screw must be M16-2.0 x 40mm hot-dip galvanized bolts.

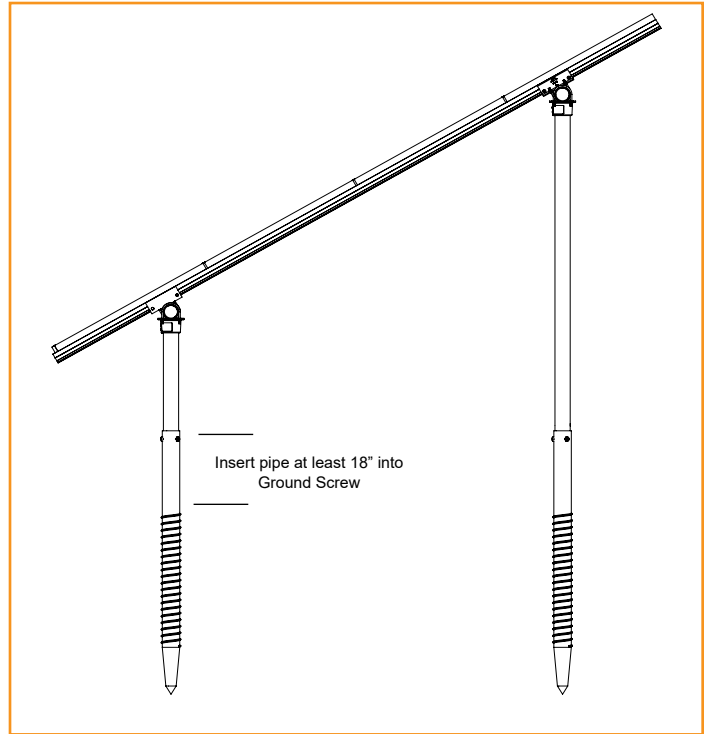

2. CONNECT SUBSTRUCTURE

A. MOUNT TOP CAPS

Mount a Top Cap on each vertical pier. Wait to tighten set screws.

- If using [Diagonal Braces](#), install them prior to Top Caps.

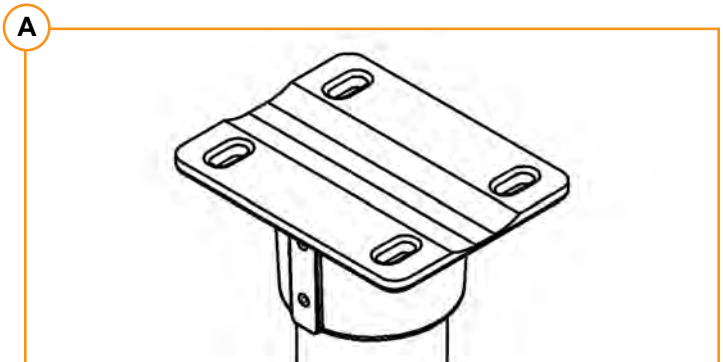

B. LAY HORIZONTAL BEAMS

Set horizontal beams (Pipe or Mechanical Tubing) in Top Cap grooves. Attach with 3/8" U-bolts, Flange Nuts, Flat Washers and Lock Washers. Torque U-bolts to **15 ft-lbs** and align assembly.

Torque Top Cap set screws to **20 ft-lbs** for Schedule 40 Grade B Pipe, **11 ft-lbs** for 2.375" x 12 ga Mechanical Tubing, and **16 ft-lbs** for 3.500" x 8 ga Mechanical Tubing.

- To join more than one section of horizontal beams, see [Page 10](#).

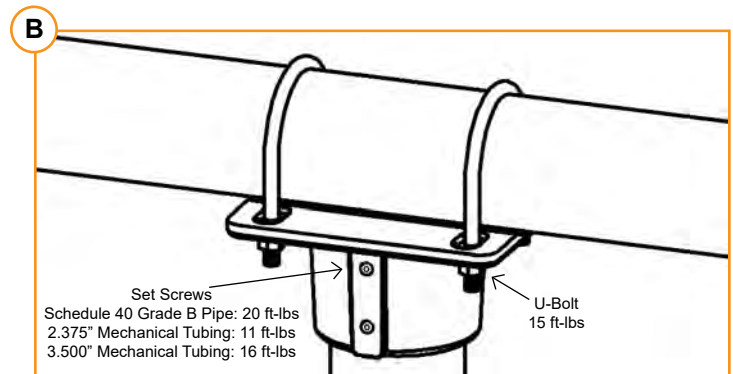

3. PLACE RAILS

A. ATTACH HARDWARE

On the ground, attach Rail Connector brackets to rail by sliding 3/8"-16 bonding bolts into side slot. Space out to match vertical pier spacing. With brackets in place, finger tighten Flange Nuts onto bolts.

- Tape ends of rail, to keep bolts from sliding out while moving.

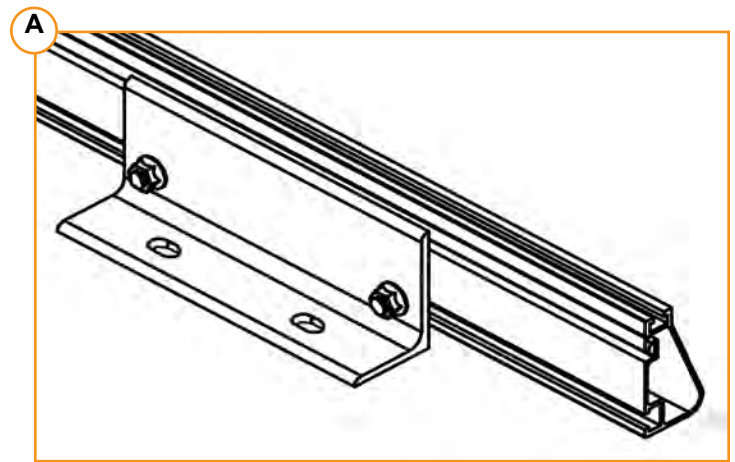

B. FASTEN CONNECTORS

Center Rails on horizontal beams, leaving equal distance on ends. Secure with Rail Connector hardware: 3/8"-16 U-bolts, Flange Nuts, Flat Washers and Lock Washers. Torque U-bolt nuts to **60 in-lbs** and bracket to **21 ft-lbs**.

- Spacing between rails should align with module manufacturer recommended clamping locations.

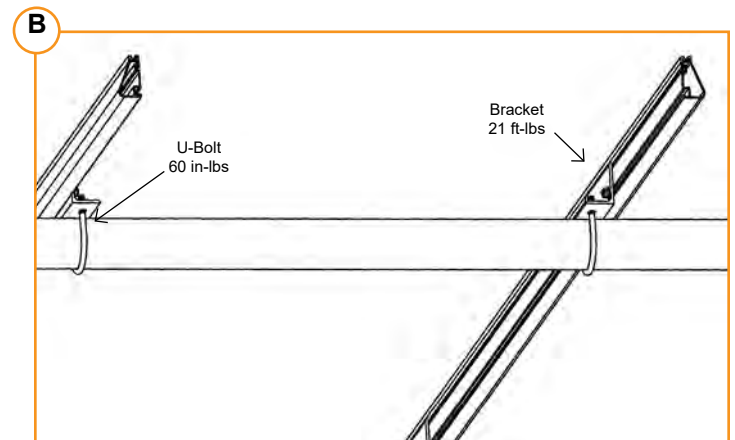

4. SECURE LUGS

Grounding Lugs

Only one Grounding Lug (Rail or Module) required per continuous subarray, regardless of subarray size (Unless frameless modules are used, see [Page 13](#)).

- Grounding Lugs are intended to for use with one solid or stranded copper wire, conductor size 10-4 AWG.

Rail Grounding Lug

Insert T-bolt in Top Rail slot and torque Hex Nut to **80 in-lbs**. Install a minimum 10 AWG solid copper or stranded grounding wire. Torque terminal screw to **20 in-lbs**.

- Rail Grounding Lugs can be installed anywhere along the Rail and in either orientation shown.

Module Grounding Lug

Insert Bolt through Module Manufacturer approved grounding location and torque Hex nut to **60 in-lbs**. One Module Grounding Lug may be installed to one module per continuous array. Install a minimum 10 AWG solid copper or stranded grounding wire. Torque terminal screw to **20 in-lbs**.

- If using Enphase microinverters or Sunpower AC modules, Grounding Lugs may not be needed. See [Page 12](#) for more info.
- Refer to module manufacturer manual for grounding instructions.

Rail Grounding Lug

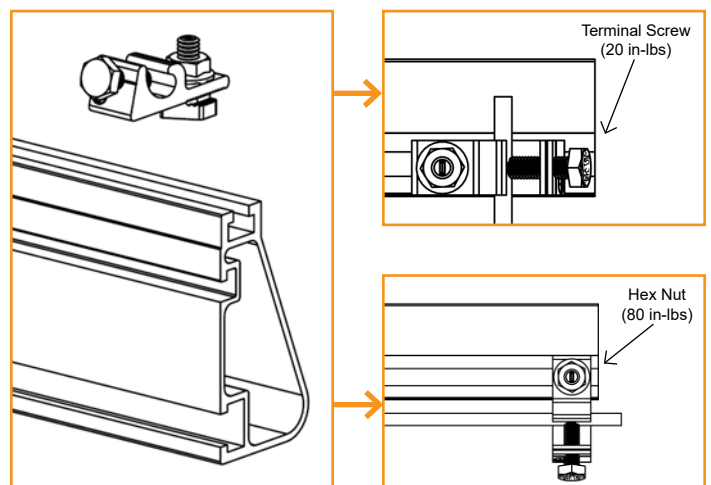

Module Grounding Lug

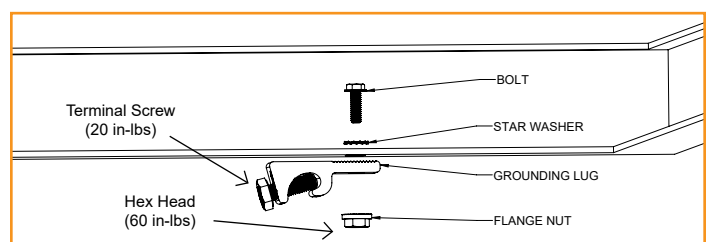

5. SECURE MODULES

A. SECURE FIRST END

Place first module in position on rails, a minimum of 1" from rail ends. Snap Stopper Sleeves onto UFO. Fasten module to rail using the UFO, ensuring that the UFO is hooked over the top of the module. Torque to **80 in-lbs**.

- Ensure rails are square before placing modules.
- Hold Stopper Sleeves on end while torquing to prevent rotation.
- If using CAMO instead of UFO + Stopper Sleeve, refer to [Page 7](#) for CAMO installation procedure.

B. SECURE NEXT MODULES

Place UFO into each rail, placing them flush against first module. Slide second module against UFO. Torque to **80 in-lbs**. Repeat for each following module.

- When reinstalling UFO, move modules a minimum of 1/16" so UFOs are in contact with a new section of module frame.
- When UFOs are loosened and re-tightened, ensure UFO T-bolt bottoms out in rail channel before re-torquing UFO to achieve full engagement between T-bolt and rail.
- If using Wire Clips, refer to [Page 9](#).

C. SECURE LAST END

Place last module in position on rails, a minimum of 1" from rail ends. Snap Stopper Sleeves onto UFO. Secure UFO Clamps on rails, ensuring they are hooked over top of module. Torque to **80 in-lbs**.

- Hold Stopper Sleeves on end while torquing to prevent rotation.
- If using CAMO instead of UFO + Stopper Sleeve, refer to [Page 7](#) for CAMO installation procedure.

D. REPEAT STEPS

Secure remaining module rows, leaving a minimum 3/8" gap between rows.

- If using End Caps, refer to [Page 9](#).

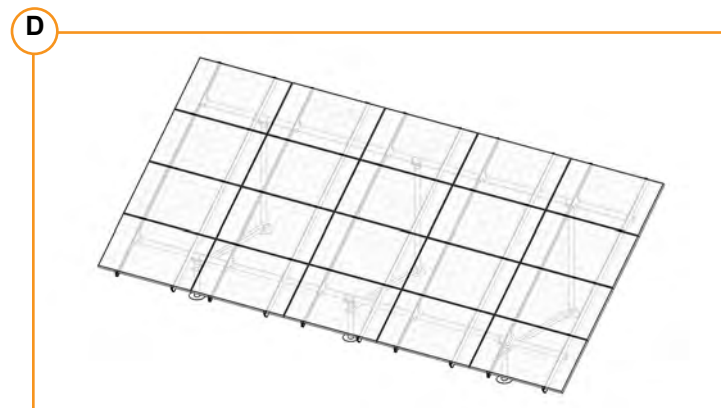
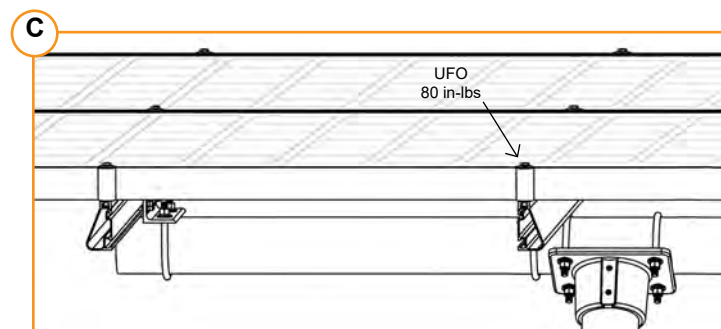
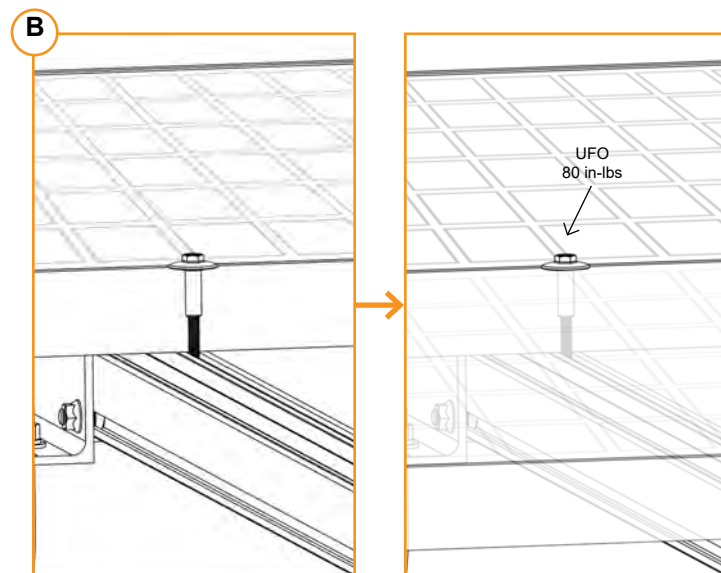
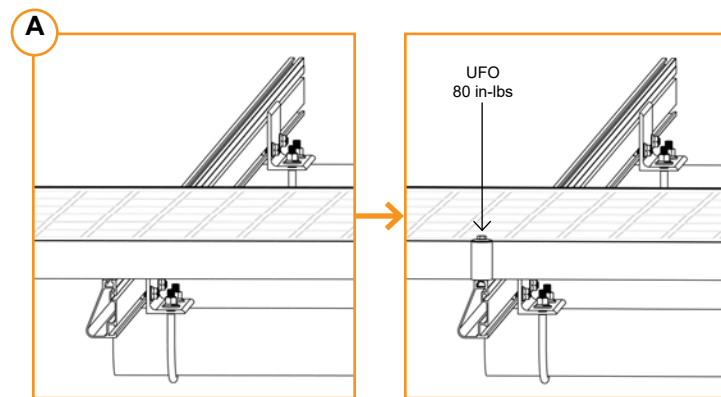

A. SLIDE INTO RAIL

Slide CAMO into rail channel far enough to clear the module frame. CAMO requires 6" of clearance from end of rail.



B. PLACE MODULE

Place module on rails (module cells not shown for clarity). When installing CAMO the module can overhang the rail no more than 1/4".



C. PULL TOWARDS END

Pull CAMO towards rail ends, at 45 degree angle, so the bonding bolt contacts the module flange edge.

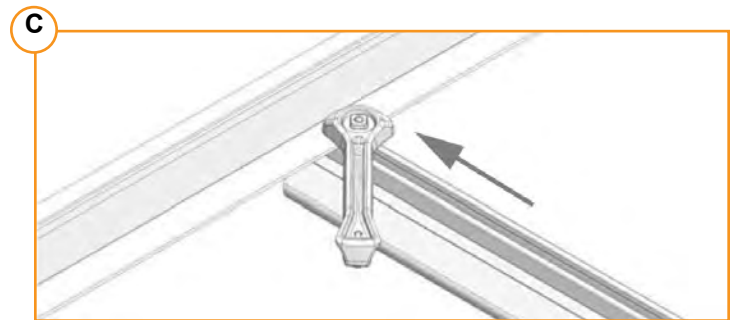

D. SECURE TO FRAME

Rotate handle with an upwards motion until CAMO snaps into rail channel. Ensure CAMO bonding pins are fully seated on top of module frame.

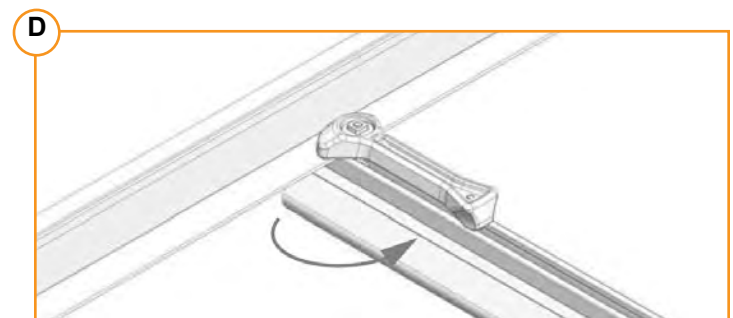

FRAME COMPATIBILITY

CAMO has been tested or evaluated with all modules listed in the Module Compatibility section having frames within the referenced dimensions. Be sure the specific module being used meets the dimension requirements.

- For installations with Hanwha Q CELLS modules with 32 mm frame heights, the maximum ground snow is 45 PSF (33 PSF module pressure).
- CAMO's compatibility with Canadian Solar modules is limited to the HiDM5 (CS1Y) modules.

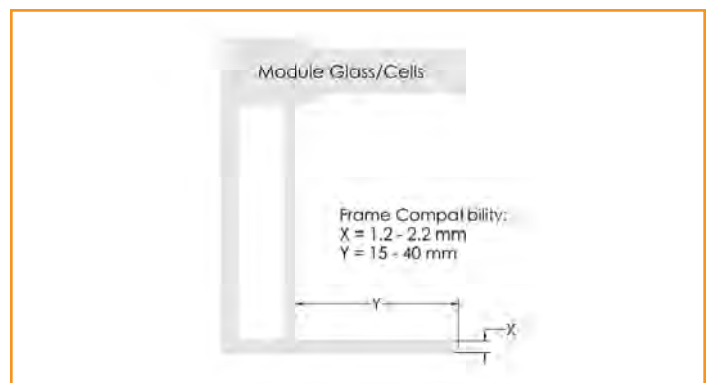

ELECTRICAL DIAGRAM

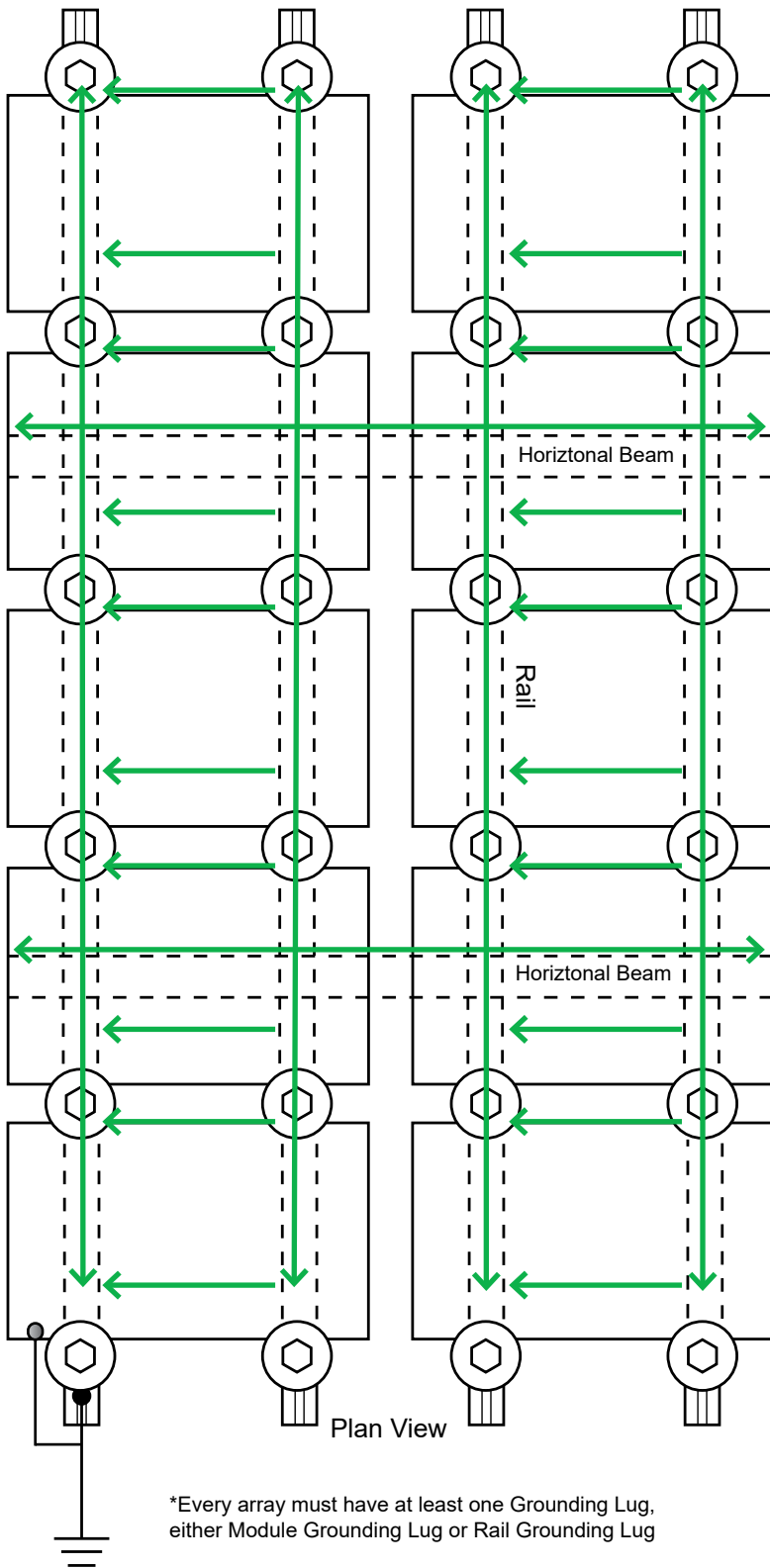

- Bonding Points ← Fault Current Ground Path
- Rail Grounding Lug*
Or
- Module Grounding Lug*

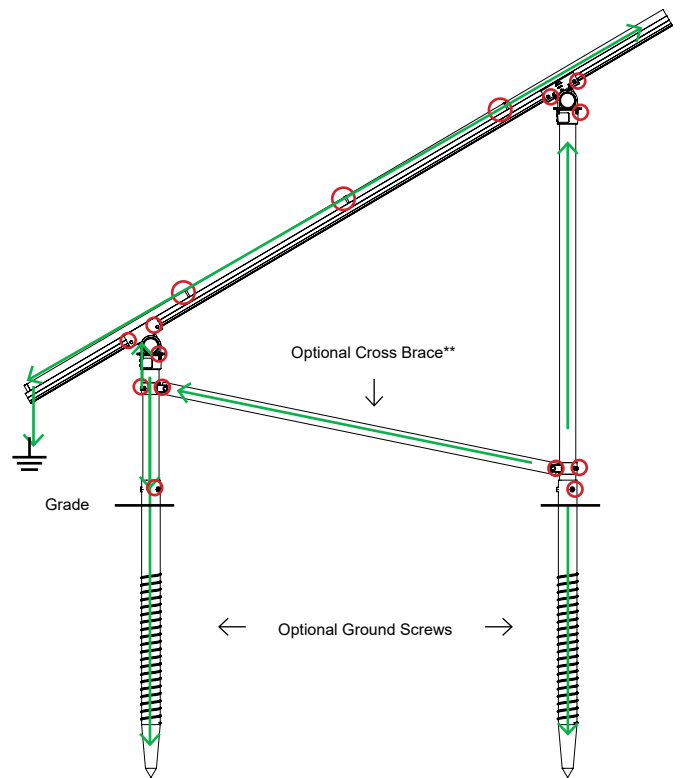
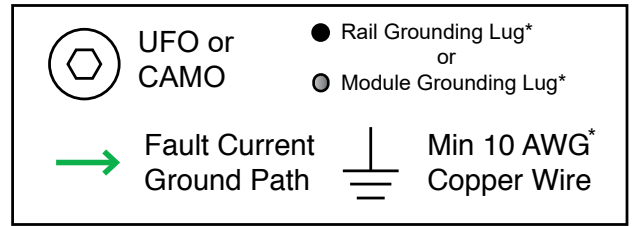

- Bonding Points ← Fault Current Ground Path
- Section View

*Grounding Lugs and wire are not required in systems using certain Enphase microinverters or certain Sunpower modules. Equipment grounding is achieved with the Engage cable for Enphase or the AC module cable system for Sunpower via their integrated EGC.

**Cross Braces are optional for concrete foundation systems.

DIAGONAL BRACES (OPTIONAL)

Slide sleeve on north pier 2-3" above the ground (6" max). Attach Diagonal Brace to sleeve with 1/2" hardware.

Slide second sleeve up on south pier 2-3" below top cap (6" max). Raise Diagonal Brace to align holes in sleeve and brace. Attach hardware and raise sleeve to full extent.

Torque Diagonal Brace bolts to **40 ft-lbs**. Torque set screws to **15 ft-lbs**.

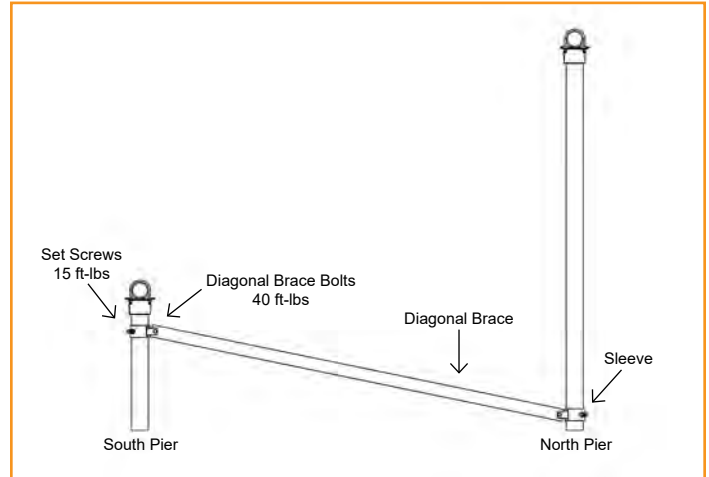

END CAPS

End Caps add a completed look and keep debris and pests from collecting inside rail.

Firmly press End Cap onto rail end.

- End Caps come in sets of left and right. Check that the proper amount of each has been provided.
- For open-structure installations, you can use adhesive to secure the End Caps.

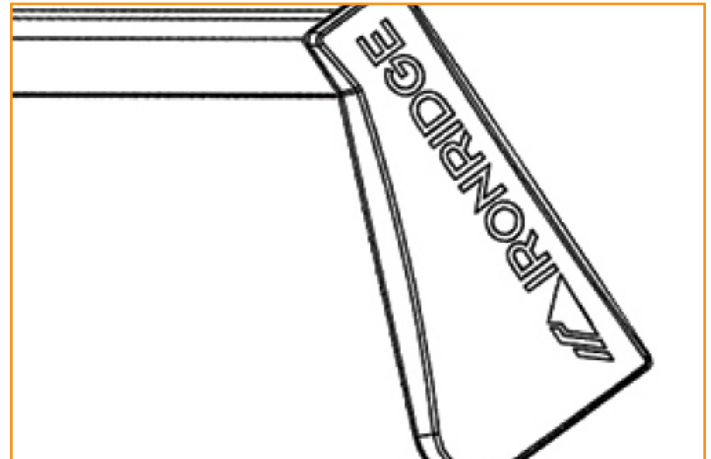

WIRE CLIPS

Wire Clips offer a simple wire management solution.

Firmly press Wire Clip into top rail slot. Open clip and insert electrical wire accordingly. Close clip once complete.

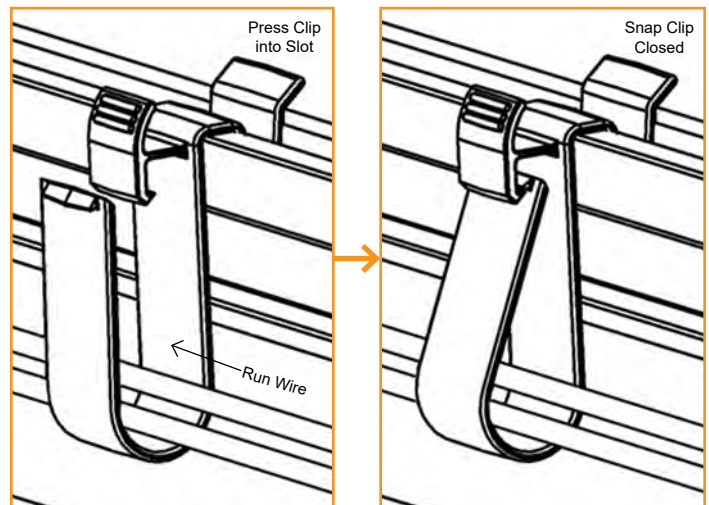

SPLICING CROSS PIPE

The following instructions should be followed, when required, to join more than one section of horizontal beam together to ensure bonding is maintained throughout the system.

A. MECHANICAL TUBING SPLICES

Mechanical tube splices shown in the table below shall be of equivalent Allied Flo-Coat, Allied Gatorshield or Wheatland ThunderCoat coating.

Mechanical Tube Size of the Structure	Splice Tube Size
2.375" OD, 12 Gauge	2.000" OD, 9 Gauge, Minimum 12" Long
3.500" OD, 8 Gauge	3.000" OD, 12 Gauge, Minimum 12" Long

Insert splice tube 6" into first section of cross tube and secure with 2 self-drilling screws (1/4"-14 x 3/4"), spacing them approximately 1.25" from end of pipe and approximately 3.50" apart, tightening screws to 9 ft-lbs.

Slide second section of cross tube over splice tube and secure with two more self-drilling screws. Tighten screws to 9 ft-lbs.

- ▶ Pre-drill 5/32" pilot holes through cross tube and splice tube for easier installation of self-drilling screws.

B. SCHEDULE 40 GRADE B PIPE SPLICES

Use galvanized threaded pipe couplings that match the pipe size used for the structure. Threaded Schedule 40 Grade B Pipe must be used when splicing cross pipe together.

Fully thread coupling onto both sections of pipe being spliced together.

- ▶ To ensure structural integrity of horizontal beams, mechanical tube or pipe coupling splices are not permitted in end spans or in middle 1/3 of interior horizontal beam spans.

C. HORIZONTAL PIPES CAN BE JOINED OVER AN INTERIOR TOP CAP WITH A MAXIMUM GAP OF 1/2"

- ▶ To avoid potential problems from the effects of thermal expansion, a maximum total continuous cross pipe length of 100 ft is recommended.

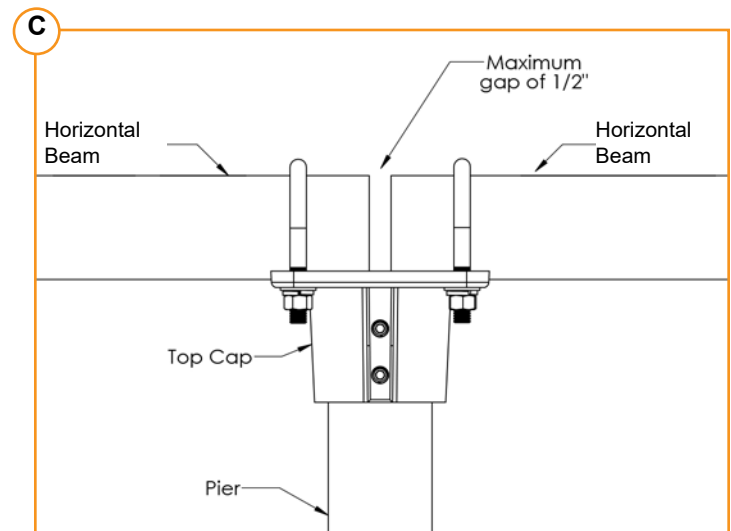
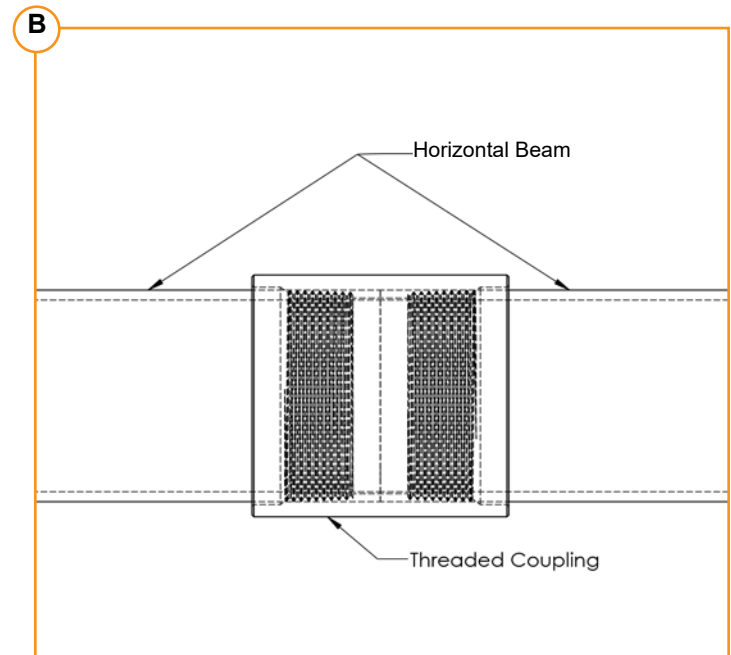
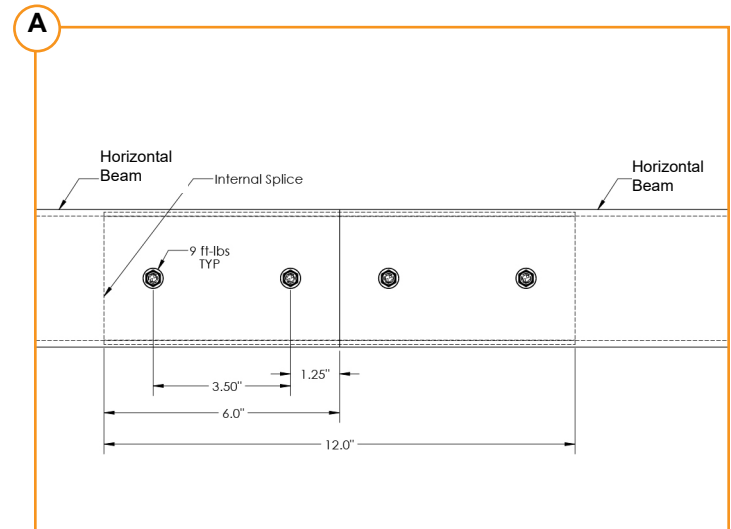

MICROINVERTER KITS

Use IronRidge's Microinverter Kit to bond compatible microinverters and power optimizers to the racking system.

Insert Microinverter Kit T-bolt into top rail slot. Place compatible microinverter or power optimizer into position and tighten hex nut to **80 in-lbs**.

If installing in areas with ground snow loads greater than 40 psf, install MLPE devices directly next to module frame edge

COMPATIBLE PRODUCTS

Enphase

M250-72, 250-60, M215-60, C250-72, S230, S280, IQ 6, IQ 6+, IQ IQ7, IQ 7A, IQ 7+, IQ 7X, Q Aggregator

Darfon

MIG240, MIG300, G320, G640

Solar Edge

M1600, P300, P320, P340, P370, P400, P401, P405, P485, P505, P600, P700, P730, P800p, P800s, P801, P850, P860, P950, P960

SMA

RoofCommKit-P2-US, TS4-R Module Retrofit Kits (TS4-R-S, TS4-R-O, TS4-R-F)

Tigo

Tigo Access Point (TAP)

TS4-R-X (where X can be F, M, O, or S)

TS4-R-X-DUO (where X can be M, O, or S)

TS4-A-X (where X can be F, 2F, O, O-DUO, or S)

AP Systems

QS1, YC600

- Remove Grounding Washer on AP Systems QS1 and YC600 inverters before installing to XR rails.
- Remove the Stainless Steel Clip on Tigo-"A" MLPE Devices before attaching to XR rails.
- Use the number of IronRidge Microinverter kits allowed by the MLPE mounting flange. Some will require 1 kit and others 2 kits.

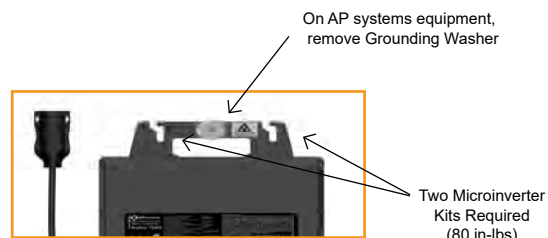
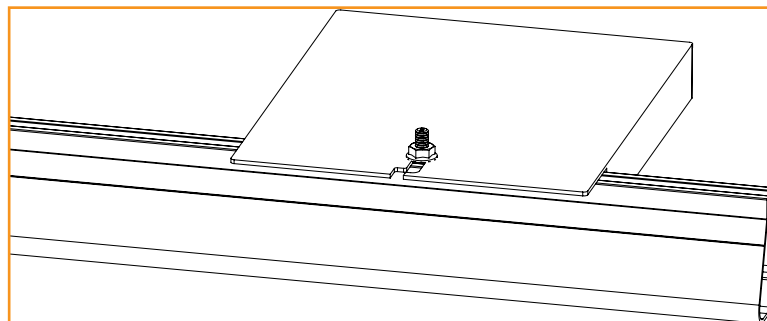
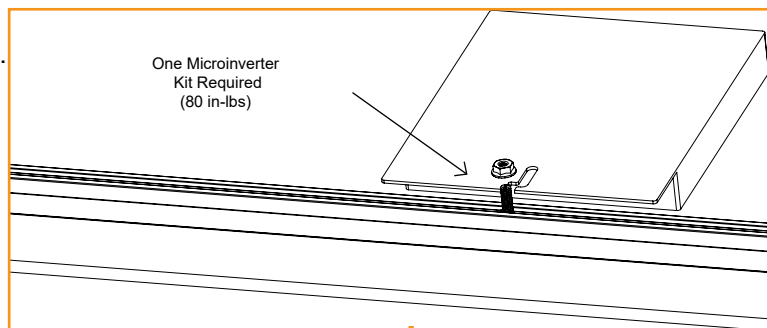

SYSTEMS USING ENPHASE MICROINVERTERS OR SUNPOWER AC MOD-

IronRidge systems using approved Enphase products or SunPower modules eliminate the need for lay-in lugs and field installed equipment grounding conductors (EGC). This solution meets the requirements of UL 2703 for bonding and grounding and is included in this listing.

COMPATIBLE PRODUCTS

Sunpower

Modules with model identifier Ab-xxx-YY and InvisiMount (G5) 46mm frame; where "A" is either E, or X; "b" can be 17, 18, 19, 20, 21, or 22; and "YY" can be C-AC, D-AC, BLK-C-AC, or BLK-D-AC.

Enphase

Microinverters M250-72, M250-60, M215-60, C250-72, and Engage cables ETXX-240, ETXX-208, ETXX-277.

- A minimum of two inverters mounted to the same rail and connected to the same Engage cable are required.
- The microinverters or Sunpower AC modules must be used with a maximum 20 A branch rated overcurrent protection device (OCPD).
- If an AC module is removed from a circuit for maintenance, you must first disconnect AC power and then install a temporary EGC to bridge the gap by inserting an AC extension cable (or via other NEC-compliant means), in order to maintain effective ground continuity to subsequent modules.

SYSTEMS USING MICROSTORAGE PRODUCTS

Use IronRidge's Microinverter Kit to bond compatible microstorage devices to the racking system. Insert Microinverter Kit T-bolt into top rail slot. Place compatible microstorage into position and tighten hex nut to **80 in-lbs**.

COMPATIBLE PRODUCTS

PHAZR

PHAZR Devices PHAZR-X, where X is 6-12.

- Running a separate equipment grounding conductor to the PHAZRs is not required.
- If installing in areas with ground snow loads greater than 40 psf and underneath a module, install PHAZR devices as close as possible to module frame edge.
- Use the number of IronRidge Microinverter kits allowed by the microstorage mounting flange. Some will require 1 kit and others 2 kits.

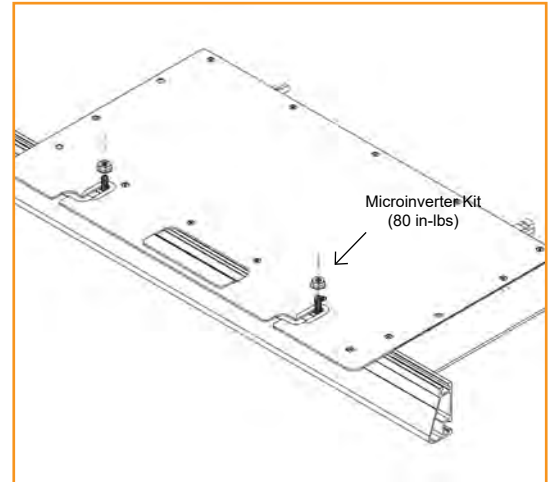

FRAMELESS MODULE KITS

Insert Frameless Kit T-bolt in top rail slot. Place star washer over T-bolt, allowing it to rest on top of rail. Secure module clamps with a hex nut and torque to **80 in-lbs**.

COMPATIBLE PRODUCTS

Sunforson

Sunforson silver or black SFS-UTMC-200(B) mid and SFS-UTEC-200(B) end clamps.

Sunpreme

Sunpreme silver or black mid and end clamps with part numbers 7500105X where "X" is 1, 5, 6 or 7.

Ironridge

IronRidge silver or black mid and end clamps with part numbers FMLS-XC-001-Y where "X" is E or M and "Y" is B or blank.

- Follow module manufacturer's installation instructions to install the module clamps.
- Frameless modules require using a Grounding Lug on every rail.
- For Sunpreme Modules Only: If required to use slide prevention hardware, see Module Slide Prevention Addendum (Version 1.10).

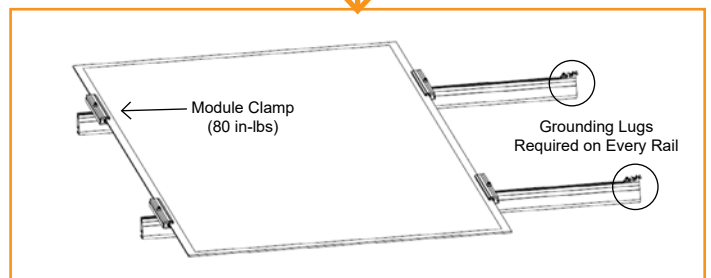
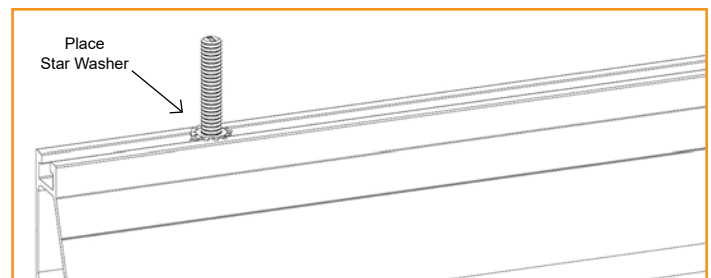

MODULE COMPATIBILITY

The Ground Mount System may be used to ground and/or mount a PV module complying with UL 2703 only when the specific module has been evaluated for grounding and/or mounting in compliance with the included instructions. Unless otherwise noted, "xxx" refers to the module power rating and both black and silver frames are included in the certification.

Framed Module List	
Make	Models
Adani	Adani modules with 35 and 40mm frames ASX-Y-ZZ-xxx Where "X" can be B, M or P, "Y" can be 6 or 7, and "ZZ" can be blank, PERC, B-PERC, or AB-PERC
Amerisolar	Amerisolar modules with 35, 40 and 50 mm frames AS-bYxxxZ Where "b" can be 5 or 6; "Y" can be M, P, M27, P27, M30, or P30; and "Z" can be blank, W or WB
Aptos Solar	Aptos modules with 35 and 40 mm frames DNA-yy-zz23-xxx Where "yy" can be 120 or 144; and "zz" can be MF or BF
Astronergy Solar	Astronergy modules with 30, 35, 40, and 45 mm frames aaSMbbyyC/zz-xxx Where "aa" can be CH or A; "bb" can be 60, 66, or 72; "yy" can be blank, 10 or 12; "C" can M, P, M(BL), M-HC, M(BL)-HC, P-HC, M(DG), or M(DGT); and "zz" can be blank, HV, F-B, or F-BH
ASUN	ASUN modules with 35 and 40 mm frames ASUN-xxx-YYZZ-aa Where "YY" can be 60 or 72; "ZZ" can be M, or MH5; and "aa" can be blank or BB
Auxin	Auxin modules with 40 mm frames AXN6y6zAxxx Where "y" can be M or P; "z" can be 08, 09, 10, 11, or 12; and "A" can be F or T
Axitec	Axitec Modules with 35 and 40 mm frames AC-xxxY/aaZZb Where "Y" can be M, P or MH; "aa" can be blank, 125- or 156-; "ZZ" can be 54, 60, 72, 120, or 144; "b" can be S, X, V, XV, or MX
Boviet	Boviet modules with 35 and 40mm frames BVM66aaYY-xxxBcc Where "aa" can be 9, 10 or 12; "YY" is M or P; and "B" can be blank, L or S; and "cc" can be blank, H, H-BF, H-BF-DG, H-HC, H-HC-BF, H-HC-BF-DG, HC-BF or HC-BF-DG
BYD	BYD modules with 35 mm frames BYDxxxAY-ZZ Where "A" can be M6, P6, MH or PH; "Y" can be C or K; and "ZZ" can be 30 or 36
Canadian Solar	Canadian Solar modules with 30, 35 and 40 mm frames CSbY-xxxZ Where "b" can be 1, 3 or 6; "Y" can be H, K, L, N, P, U, V, W, X or Y; and "Z" can be M, P, MS, PX, M-SD, P-AG, P-SD, MB-AG, PB-AG, MS-AG, or MS-SD
CertainTeed	CertainTeed modules with 35 and 40 frames CTxxxYZZ-AA Where "Y" can be M, P, or HC; "ZZ" can be 00,01, 10, or 11; and "AA" can be 01, 02, 03, or 04
CSUN	Csun modules with 35 and 40 mm frames YYxxx-zzAbb Where "YY" is CSUN or SST; "zz" is blank, 60, or 72; and "A" is blank, P or M; "bb" is blank, BB, BW, or ROOF

MODULE COMPATIBILITY

Dehui	Dehui modules with 30, 35 and 40mm frames DH-MYYYYZ-xxx Where “YYY” can be 760, 772, 860, 872; and “Z” can be B, F or W
Ecosolargy	Ecosolargy modules with 35, 40, and 50 mm frames ECOxxxYzzA-bbD Where “Y” can be A, H, S, or T; “zz” can be 125 or 156; “A” can be M or P; “bb” can be 60 or 72; and “D” can be blank or B
ET Solar	ET Solar modules with 30, 35, 40, and 50 mm frames ET-Y6ZZxxxAA Where “Y” can be P, L, or M; “ZZ” can be 60, 72 or 72BH; and “AA” can be GL, WB, WW, BB, WBG, WWG, WBAC, WBCO, WWCO, WWBCO or BBAC
Flex	Flex modules with 35, 40, and 50 mm frames FXS-xxxYY-ZZ; Where “YY” can be BB or BC; and “ZZ” can be MAA1B, MAA1W, MAB1W, SAA1B, SAA1W, SAC1B, SAC1W, SAD1W, SBA1B, SBA1W, SBC1B, or SBC1W
GCL	GCL modules with 35 mm and 40 mm frames GCL-ab/YY xxx Where “a” can be M or P; “b” can be 3 or 6; and “YY” can be 60, 72, 72H, or 72DH
GigaWatt Solar	Gigawatt modules with 40 mm frames GWxxxYY Where “YY” can be either PB or MB
Hansol	Hansol modules with 35 and 40 frames HSxxxYY-zz Where “YY” can be PB, PD, PE, TB, TD, UB, UD, or UE; and “zz” can be AH2, AN1, AN3, AN4, HH2, HV1, or JH2
Hanwa Solar	Hanwa Solar modules with 40, 45, and 50 mm frames HSLaaP6-YY-1-xxxZ Where “aa” can be either 60 or 72; “YY” can be PA or PB; and “Z” can be blank or B
Hanwha Q CELL	Hanwha Q CELLS Modules with 32, 35, 40, and 42mm frames aaYY-ZZ-xxx where “aa” can be Q. or B.; “YY” can be PLUS, PRO, PEAK, LINE PRO, LINE PLUS, PLUS DUO or PEAK DUO; and “ZZ” can be G3, G3.1, G4, G4.1, L-G2, L-G2.3, L-G3, L-G3.1, L-G3y, L-G4, L-G4.2, L-G4y, LG4.2/TAA, BFR-G3, BLK-G3, BFR-G3.1, BLK-G3.1, BFR-G4, BFR-G4.1, BFR G4.3, BLK-G4.1, G4/SC, G4.1/SC, G4.1/TAA, G4.1/MAX, BFR G4.1/TAA, BFR G4.1/MAX, BLK G4.1/TAA, BLK G4.1/SC, EC-G4.4, G5, G5/SC, G5/TS, BLK-G5, BLK-G5/SC, BLK-G5/TS, L-G5, L-G5.1, L-G5.2, L-G5.2/H, L-G5.3, G6, G6/SC, G6/TS, G6+/TS, G6+, BLK-G6, L-G6, L-G6.1, L-G6.2, L-G6.3, G7, BLK-G6+, BLK-G6+/AC, BLK-G6+/SC, BLK-G6/TS, BLK-G6+/TS, BLK-G7, G7.2, G8, BLK-G8, G8+, BLK-G8+ L-G7, L-G7.1, L-G7.2, L-G7.3, L-G8, L-G8.1, L-G8.2, L-G8.3, L-G8.3/BFF, L-G8.3/BFG, ML-G9, BLK ML-G9, ML-G9+, BLK ML-G9+, XL-G9, XL-G9.2 or XL-G9.3
Heliene	Heliene modules with 40 mm frames YYZZxxxA Where “YY” can be 36, 60, 72, or 96; “ZZ” can be M, P, or MBLK; and “A” can be blank, HomePV, or Bifacial
HT-SAAE	HT-SAAE modules with 35 and 40 mm frames HTyy-156Z-xxx Where “yy” can be 60 or 72, “Z” can be M, P, M-C, P-C, M(S), M(VS), M(V), P(V), M(V)-C, P(V)-C
Hyundai	Hyundai modules with 33, 35, 40 and 50 mm frames HiY-SxxxZZ Where “Y” can be A, D, M or S; and “ZZ” can be GI, HG, HI, KI, MI, MF, MG, PI, RI, RG, RG(BF), RG(BK), SG, TI, or TG

MODULE COMPATIBILITY

Itek	Itek Modules with 40 and 50 mm frames IT-xxx-YY Where “YY” can be blank, HE, or SE, or SE72
JA Solar	JA Solar modules with 30, 35, 40 and 45 mm frames JAyyzz-bbww-xxx/aa Where “yy” can be M, P, M6 or P6; “zz” can be blank, (K), (L), (R), (V), (BK), (FA), (TG), (FA)(R), (L)(BK), (L)(TG), (R)(BK), (R)(TG), (V)(BK), (BK)(TG), or (L)(BK)(TG); “bb” can be 48, 60, or 72; “ww” can be D09, S01, S02, S03, S06, S09, S10, or S12; and “aa” can be BP, MR, SI, SC, PR, 3BB, 4BB, 4BB/RE, 5BB
Jinko	Jinko modules with 35 and 40 mm frames JKMYxxxZZ-aa Where “Y” can either be blank or S; “ZZ” can be M, P, or PP; and “aa” can be blank, 60, 60B, 60H, 60L, 60BL, 60HL, 60HB, 60HBL, 6HBL-EP, 60-J4, 60B-J4, 60B-EP, 60(Plus), 60-V, 60-MX, 6RL3-B, 6TL3-B, 7RL3-V, 7RL3-TV, 72, 72B, 72-J4, 72B-J4, 72(Plus), 72-V, 72H-V, 72L-V, 72HL-V, 72-MX, 72H-BDVP, 72HL-TV, or 72HL-V-MX3
Kyocera	Kyocera Modules with 46mm frames KYxxxZZ-AA Where “Y” can be D or U; “ZZ” can be blank, GX, or SX; and “AA” can be LPU, LFU, UPU, LPS, LPB, LFB, LFBS, LFB2, LPB2, 3AC, 3BC, 3FC, 4AC, 4BC, 4FC, 4UC, 5AC, 5BC, 5FC, 5UC, 6BC, 6FC, 8BC, 6MCA, or 6MPA
LG	LG modules with 35, 40, and 46 mm frames LGxxxYaZ-bb Where “Y” can be A, E, M, N, Q, S; “a” can be A, 1 or 2; “Z” can be C, K, T, or W; and “bb” can be A3, A5, A6, B3, B6, E6, G3, G4, J5, K4, L5, N5, or V5
Longi	Longi modules with 30, 35 and 40 mm frames LRa-YYZZ-xxxM Where “a” can be 4 or 6; “YY” can be blank, 60 or 72; and “ZZ” can be blank, BK, BP, HV, PB, PE, PH, HBD, HIB, HIH, HPB, HPH, or HIBD
Mission Solar	Mission Solar modules with 33 and 40 mm frames MSEbbxxxZZaa Where “bb” can be blank or 60A; “ZZ” can be blank, MM, SE, SO, SQ, SR, or TS; and “aa” can be blank, 1J, 4J, 4S, 5K, 5T, 60, 6J, 6S, 6W, 8K, 8T, or 9S
Mitsubishi	Mitsubishi modules with 46 mm frames PV-MYYxxxZZ Where “YY” can be LE or JE; and “ZZ” can be either HD, HD2, or FB
Motech	IM and XS series modules with 40, 45, and 50 mm frames
Next Energy Alliance	Next Energy Alliance modules with 35 and 40mm frames yyNEA-xxxZZ where “yy” can be blank or US; “ZZ” can be M, MB or M-60
Neo Solar Power	Neo Solar Power modules with 35 mm frames D6YxxxZZaa Where “Y” can be M or P; “ZZ” can be B3A, B4A, E3A, E4A, H3A, H4A; and “aa” can be blank, (TF), ME or ME (TF)
Panasonic (HIT)	Panasonic modules with 35 and 40 mm frames VBHNxxxYYzzA Where “YY” can be either KA, RA, SA or ZA; “zz” can be either 01, 02, 03, 04, 06, 06B, 11, 11B, 15, 15B, 16, 16B, 17, or 18; and “A” can be blank, E, G, or N
Panasonic (EverVolt)	Panasonic modules with 30 mm frames EVPVxxxA Where “A” can be blank or K
Peimar	Peimar modules with 40 mm frames SbxxxYzz Where “b” can be G, M or P; “Y” can be M or P; and “zz” can be blank, (BF) or (FB)
Philadelphia Solar	Philadelphia modules with 35 and 40 mm frames PS-YzzAA-xxx Where “Y” can be M or P; “zz” can be 60 or 72; and “AA” can be blank or (BF)

MODULE COMPATIBILITY

Phono Solar	Phono Solar modules with 35, 40, and 45 mm frames PSxxxY-ZZ/A Where “Y” can be M, M1, MH, or M1H or P; “ZZ” can be 20 or 24; and “A” can be F, T, U, or TH
Recom	Recom modules with 35 and 40 mm frames RCM-xxx-6yy Where “yy” can be MA, MB, ME or MF
REC Solar	REC modules with 30, 38 and 45 mm frames RECxxxYYZZ Where “YY” can be AA, M, NP, PE, PE72, TP, TP2, TP2M, TP2SM, TP2S, or TP3M; and “ZZ” can be blank, Black, BLK, BLK2, SLV, or 72
Renesola	ReneSola modules with 35, 40 and 50 mm frames AAxxxY-ZZ Where “AA” can be SPM(SLP) or JC; “Y” can be blank, F, M or S; and “ZZ” can be blank, Ab, Ab-b, Abh, Abh-b, Abv, Abv-b, Bb, Bb-b, Bbh, Bbh-b, Bbv, Bbv-b, Db, Db-b, or 24/Bb
Renogy	Renogy Modules with 40 and 50 mm frames RNG-xxxY Where “xxx” is the module power rating; and “Y” can be D or P
Risen	Risen Modules with 30, 35 and 40 mm frames RSMyy-6-xxxZZ Where “yy” can be 60, 72, 120, 132 or 144; and “ZZ” can be M, P or BMDG
S-Energy	S-Energy modules with 35 and 40mm frames SABB-CCYYY-xxxZ Where “A” can be C, D, L or N; “BB” can be blank, 20, 25, 40 or 45; “CC” can be blank, 60 or 72; “YYY” can be blank, BDE, MAE, MAI, MBE, MBI, MCE or MCI; and “Z” can be V, M-10, P-10 or P-15
Seraphim Energy Group	Seraphim modules with 30, 35 and 40 mm frames SEG-aYY-xxxZZ Where “a” can be blank, 6 or B; “YY” can be blank, MA, MB, PA, or PB; and “ZZ” can be blank, BB, BG, BW, HV, WB, WW, BMB, BMA-HV, BMA-BG, BMB-HV
Seraphim USA	Seraphim modules with 40 and 50 mm frames SRP-xxx-6YY-ZZ Where “xxx” is the module power rating; and “YY” can be MA, MB, PA, PB, QA-XX-XX, and QB-XX-XX; ZZ is blank, BB or HV
Sharp	Sharp modules with 35 and 40 mm frames NUYYxxx Where “YY” can be SA or SC
Silfab	Silfab Modules with 38 mm frames SYY-Z-xxxAb Where “YY” can be IL, SA, LA, SG or LG; “Z” can be blank, M, P, or X; “A” can be blank, B, H, M, N; and “b” can be A, L, G, K or T
Solaria	Solaria modules with 40 mm frames PowerXT xxxY-ZZ Where “Y” can be R or C; and “ZZ” can be AC, BD, BX, BY, PD, PM, PM-AC, PX, PZ, WX or WZ
Solarcity (Tesla)	Solarcity modules with 40 mm frames SCxxxYY Where “YY” can be blank, B1 or B2
SolarTech	SolarTech modules with 42 mm frames STU-xxxYY Where “YY” can be PERC or HJT
SolarWorld AG	SolarWorld Sunmodule Plus, Protect, Bisun, XL, Bisun XL, may be followed by mono, poly, duo, black, bk, or clear; modules with 31, 33 or 46 mm frames SW-xxx

MODULE COMPATIBILITY

SolarWorld Americas	SolarWorld Sunmodule Plus, Protect, Bisun, XL, Bisun XL, may be followed by mono, poly, duo, black, bk, or clear; modules with 33 mm frames SWA-xxx
Sonali	Sonali Modules with 40 mm frames SSxxx
Stion	Stion Thin film modules with 35 mm frames STO-xxx or STO-xxxA
SunEdison	SunEdison Modules with 35, 40 & 50 mm frames SE-YxxxZABCDE Where "Y" can be B, F, H, P, R, or Z; "Z" can be 0 or 4; "A" can be B,C,D,E,H,I,J,K,L,M, or N; "B" can be B or W; "C" can be A or C; "D" can be 3, 7, 8, or 9; and "E" can be 0, 1 or 2
Suniva	Suniva modules with 35, 38, 40, 46, and 50 mm frames OPTxxx-AA-B-YYY-Z MVXxxx-AA-B-YYY-Z Where "AA" is either 60 or 72; "B" is either 4 or 5; "YYY" is either 100,101,700,1B0, or 1B1; and "Z" is blank or B
Sunpower	Sunpower standard (G3 or G4) or InvisiMount (G5) 40 and 46 mm frames SPR-Zb-xxx-YY Where "Z" is either A, E, P or X; "b" can be blank, 17, 18, 19, 20, 21, or 22; and "YY" can be blank, BLK, COM, C-AC, D-AC, E-AC, BLK-E-AC, G-AC, BLK-C-AC, or BLK-D-AC
Sunspark	Sunspark modules with 40 mm frames SYY-xxxZ-A Where "YY" can be MX or ST; and "Z" can be M, MB, M3, M3B, P or W; and "A" can be 60 or 72
Suntech	Suntech Modules with 35, 40 and 50mm frames STPxxx-y-zz/aa Where "y" is blank or S; and "zz" can be 20, 24, A60 or A72U; and "aa" can be Vd, Vem, Vfw, Vfh, Wdb, Wde, Wd, or Wfhh
Talesun	Talesun modules with 30, 35 and 40mm frames TA6yZZaaxxx-b Where "A" can be D or P, "y" can be blank, F, G, H, or L; "ZZ" can be 60 or 72; "aa" can be M, M(H), or P; and "b" can be blank, B, T, or (H)
Trina	Trina Modules with 30, 35, 40 and 46mm frames TSM-xxxYYZZ Where "YY" can be DD05, DD06, DD14, DE14, DE15, DEG15, PA05, PC05, PD05, PD06, PA14, PC14, PD14, PE14, or PE15; and "ZZ" can be blank, .05, .08, .10, .18, .08D, .18D, 0.82, .002, .00S, 05S, 08S, A, A.05, A.08, A.10, A.18, A(II), A.05(II), A.08(II), A.082(II), A.10(II), A.18(II), H, H(II), H.05(II), H.08(II), HC.20(II), HC.20(II), M, M(II), M.05(II), MC.20(II)
URE	URE modules with 35 mm frames DyZxxxHaa Where "y" can be 6 or 7; "Z" can be K or M; and "aa" can be H3A, H4A, or H8A
Vikram	Vikram solar modules with 40 mm frames VSyy.ZZ.AAA.bb Where "yy" can be M, P, MBB, MH, MS, MHBB, or PBB; "ZZ" can be 60 or 72; "AAA" is the module power rating; and "bb" can be 03, 04 or 05
VSUN	VSUN modules with 35 and 40 mm frames VSUNxxx-YYz-aa Where "YY" can be 60, 72, 120, or 144; "z" can be M, P, MH, PH, or BMH; and "aa" can be blank, BB, BW, or DG
Waaree	Waaree modules with 40mm frames WSyy-xxx where "yy" can be blank, M, or MB
Winaico	Winaico modules with 35 and 40 mm frames Wsy-xxxZa Where "y" can be either P or T; "Z" can be either M, P, or MX; and "a" can be blank or 6
Yingli	Panda, YGE, YGE-U, and YLM series modules with 35, 40, and 50 mm frames

MODULE COMPATIBILITY

FRAMELESS MODULE LIST

MAKE	MODELS
Astronergy Solar	Astronergy frameless modules CHSM6610P(DG)-xxx
Canadian Solar	Canadian Solar frameless modules CSbY-xxx-Z Where “b” can be 3 or 6; “Y” is K, P, U, or X; and “Z” can be M-FG, MS-FG, P-FG, MB-FG, or PB-FG
Heliene	Heliene frameless modules YYZZxxxA Where “YY” can be 72; “ZZ” can be M; and “A” can be GH
Jinko	Jinko frameless modules JKMxxxPP-DV
Prism Solar	Prism Solar frameless modules BiYY-xxxBSTC Where “YY” can be 48, 60, 60S, 72 or 72S
Risen	Risen frameless modules RSMyy-6-xxxZZ Where “yy” can be 60, 72, 120 or 144; and “ZZ” can be MDG or PDG
Stion	Stion frameless modules STL-xxx or STL-xxxA
Sunpreme	Sunpreme frameless modules GXB-xxxYY Where “YY” can be blank or SL
Trina	Trina frameless modules TSM-xxxYY Where “YY” can be either DEG5(II), DEG5.07(II), DEG5.40(II), DEG5.47(II), DEG14(II), DEG14C(II), DE- G14C.07(II), DEG14.40(II), PEG5, PEG5.07, PEG5.40, PEG5.47, PEG14, or PEG14.40