

1. Introduction

The Auto Transfer Transformer (ATS-US) controls the switch of the contactors to provide power to the critical load stated as EPS Emergency Power Supply load in both grid-tied and off-grid conditions. There is a contactor in ATS-US to provide user a simple connection. ATS-US is operating with PCS inverter for the purpose of providing the split phase power when grid accidentally or unexpectedly goes off. This approach allows the home critical continuously to be supplied.

2. The location of ATS-US in the system

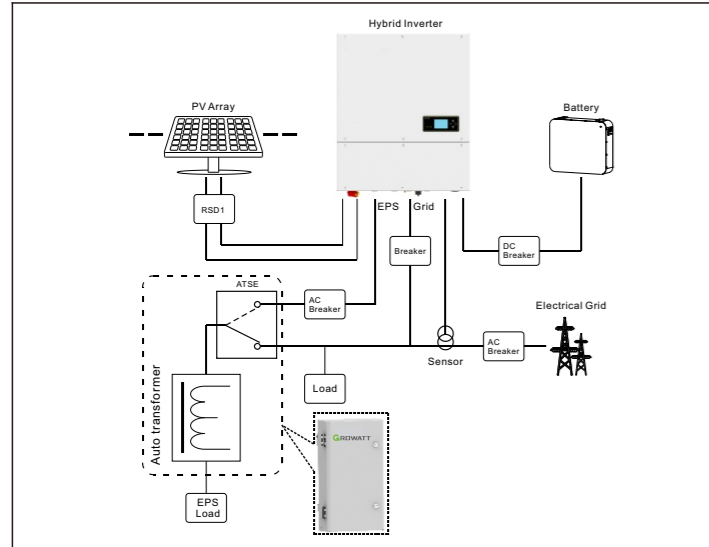

As shown in chart 2.1, the input side of ATS-US is connected with EPS output of hybrid inverter and grid, the output side is connected with critical load stated as EPS load. EPS Load is set default to connect with Grid power. If Grid is lost, EPS Load will turn the switch to EPS output of hybrid inverter. And there is a transformer in ATS-US, it can transform 240V to 120/240V split phase to provide the power to critical load.

3. Configuration

Model name	ATS-US
Grid Rated Voltage	240V
Grid Rated Frequency	50 /60Hz
Grid Rated Current	21 a.c.A ^a ,48 a.c.A ^b
EPS Rated Voltage	240V
EPS Rated Frequency	50 /60Hz
EPS Rated Current	21 a.c.A ^a ,48 a.c.A ^b
Load Rated Voltage	120/240V
Load Rated Current	21 a.c.A ^a ,48 a.c.A ^b
Load Rated power(L-L)	5000VA ^a ,11400VA ^b
Load Rated balanced power(L-N)	5000VA ^a ,11400VA ^b
Load Rated unbalanced power(L-N)	3000W
Cooling Concept	Natural
Ingress Protection	IP65/NEMA type 4X
Installation	Wall Mountable
Operation Ambient Temperature	-25°C~+50°C(-13 to+122°F)
Weight	15.6kg/34.3lb
Size	480*275*105mm/18.9*10.8*4.1in

Above a:ATS 5000T-US,b:ATS 11400T-US

4. General Information - Parts List

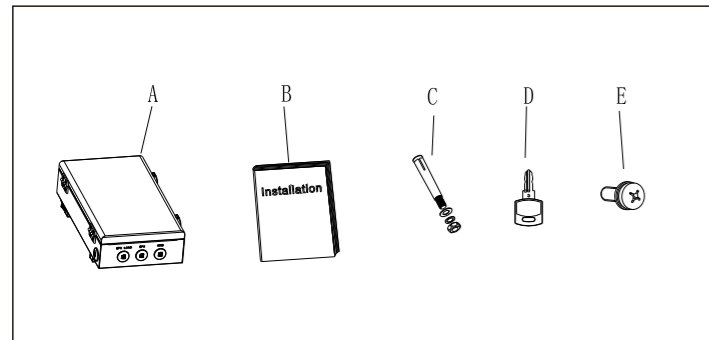

Part List					
Item	Item Name	Qty	Item	Item Name	Qty
A	ATS-US (Auto Transfer Transformer)	1	E	Fixing screws	2
B	User Manual	1	/	/	/
C	Anchor Bolt	3	/	/	/
D	Key	2	/	/	/

5. Dimension & Weight

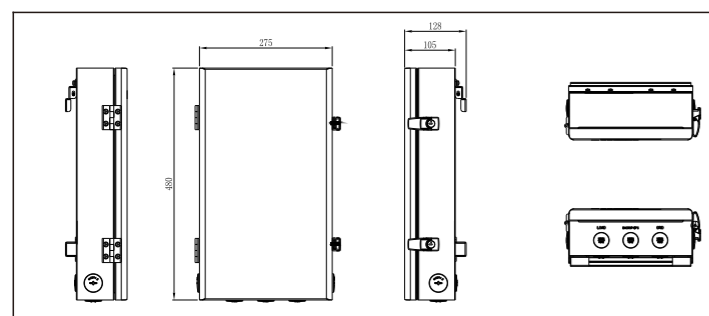

Dimension (L x W x H): 480*275*105mm/18.9*10.8*4.1in
Weight: 15.6KG/34.3lb

6. Tools

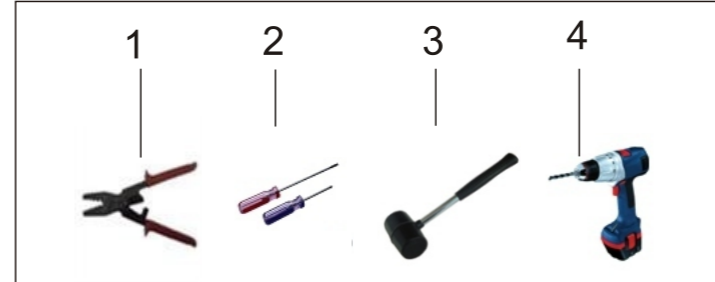

NO.	Description
1	Press terminal connector
2	Screw driver
3	Knock explosion bolt
4	Drill holes on the wall

7. Wall Mount Installation

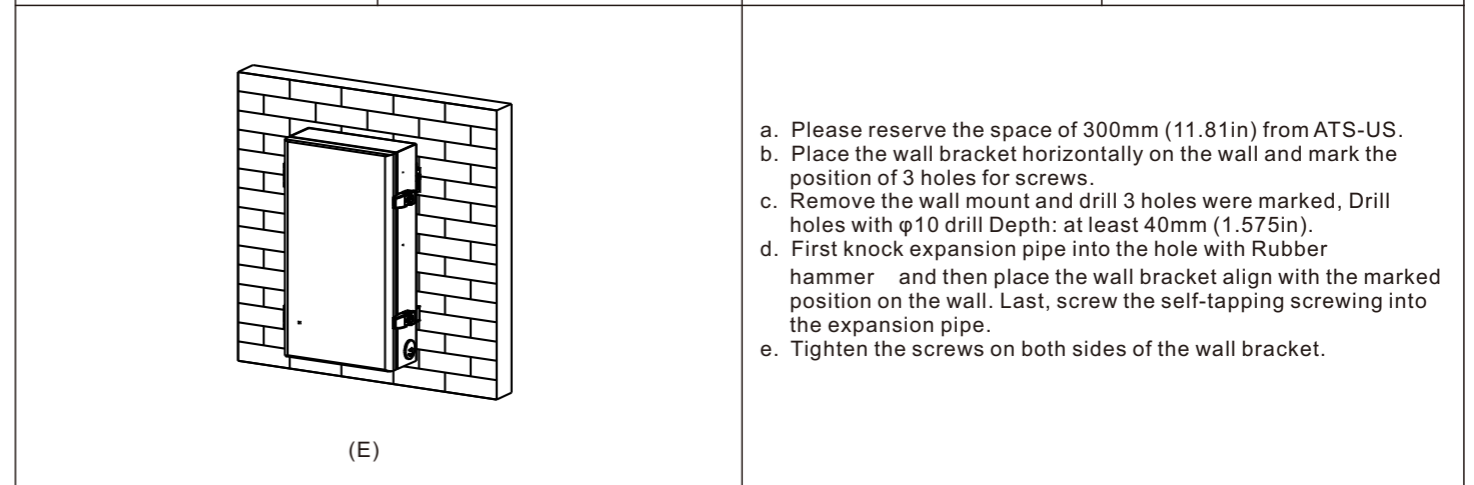
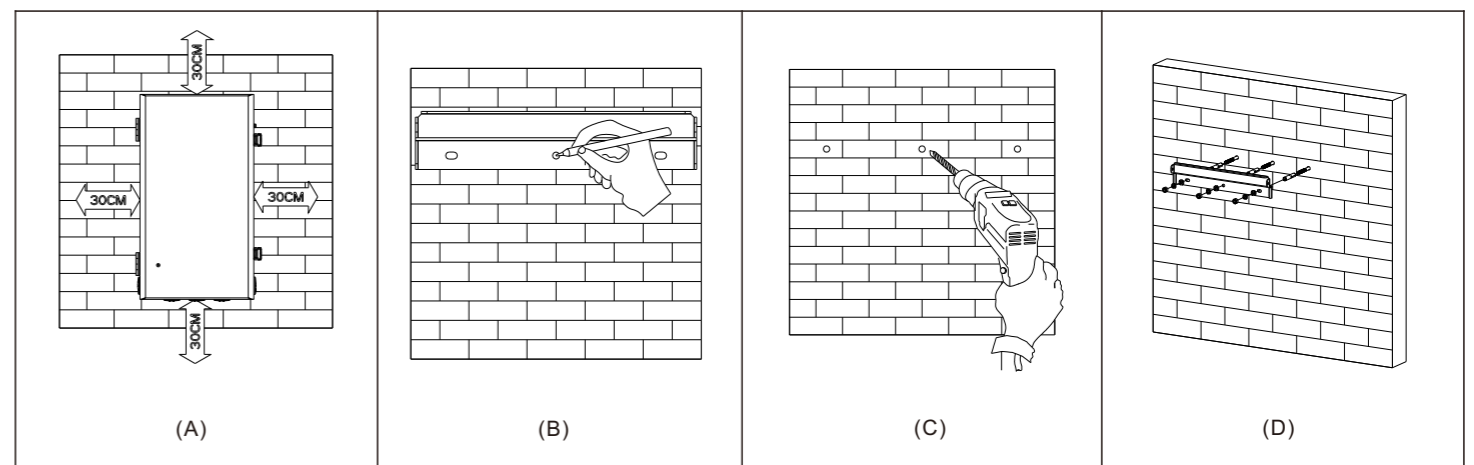

- Please reserve the space of 300mm (11.81in) from ATS-US.
- Place the wall bracket horizontally on the wall and mark the position of 3 holes for screws.
- Remove the wall mount and drill 3 holes were marked, Drill holes with $\phi 10$ drill Depth: at least 40mm (1.575in).
- First knock expansion pipe into the hole with Rubber hammer and then place the wall bracket align with the marked position on the wall. Last, screw the self-tapping screwing into the expansion pipe.
- Tighten the screws on both sides of the wall bracket.

8. Open the ATS-US

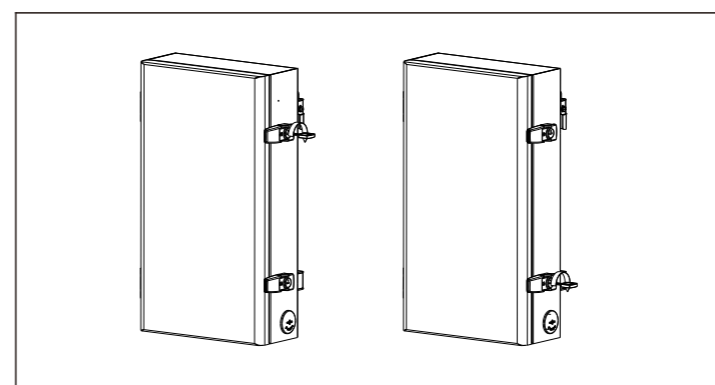





As shown above, please put the key into the Keyhole on the ATS-US top right and bottom right and clockwise rotation to 90°.The cover can be opened. Rotate 90° counterclockwise to remove the key. The cover can be pressed directly to close the cover.

9. Wiring Connection

9.1 Wires Making

1. Wires below are needed before installation.

Cable	Cable description			
	Type	Conductor Cross-sectional Area Range	Source	
 10AWG wires*6pcs ^a  8AWG wires*6pcs ^b	AC GRID power cable	1. Use cables that can withstand 90°C (194°F) or 105°C (221°F). 2. use four single-core outdoor copper cables (L1, N, L2, PE).	L1, N, L2: 10-6 AWG PE: 6 AWG	Purchased by customer
 10AWG wires*1pcs ^a  8AWG wires*1pcs ^b	EPS power cable	1. Use cables that can withstand 90°C (194°F) or 105°C (221°F). 2. Two single-core outdoor copper cables (L1 and L2)	12-6 AWG	Purchased by customer
 GND wires*3pcs	EPS output power cable	1. Use cables that can withstand 90°C (194°F) or 105°C (221°F). 2. use four single-core outdoor copper cables (L1, N, L2, PE).	L1, N, L2: 10-6 AWG PE: 6 AWG	Purchased by customer

Picture above a:ATS 5000T-US,b:ATS 11400T-US

2. Use the diagonal plier to trip 15mm of insulation from one side of the 10AWG wires (7pcs).
Use the diagonal plier to trip one side of GND wire about 7mm (3pcs).

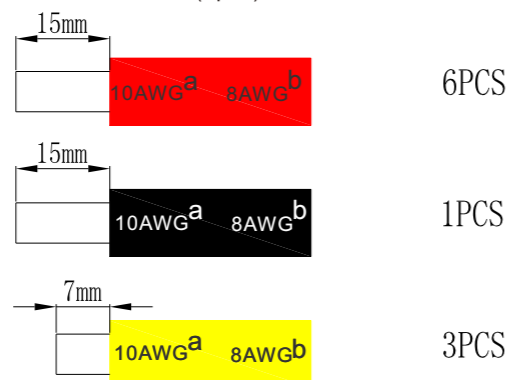

Picture above a:ATS 5000T-US,b:ATS 11400T-US

9.2 BACKUP Connection

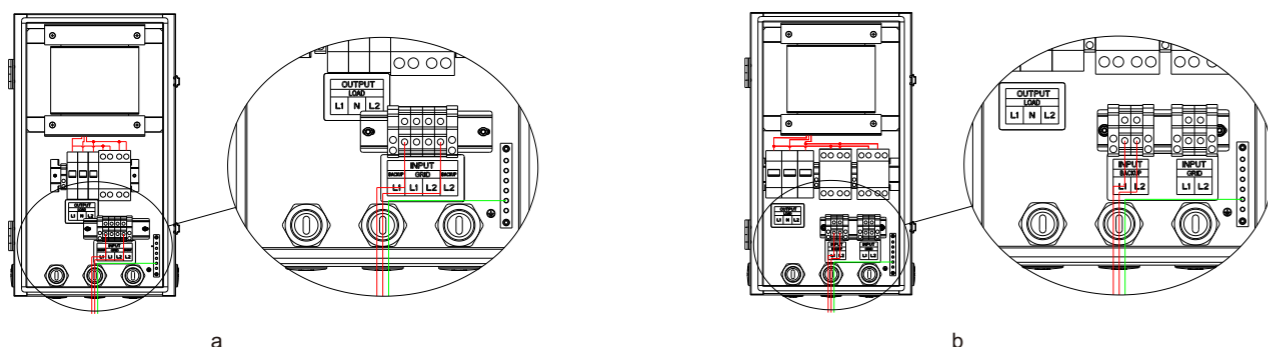

1. Use the screwdriver to loosen screws in positions L1 and L2 at the contactor's BACKUP inputs.
2. Insert L1 and L2 of the backup conductors into the BACKUP input terminals of L1 and L2.
3. Tighten to 2.5Nm.
4. Use the screwdriver to secure the backup EGC to the grounding bus bar.

9.3 GRID Connection

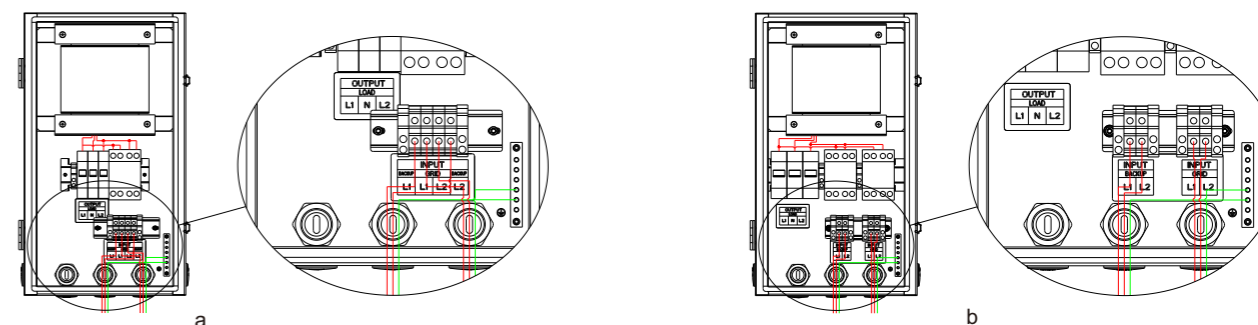

1. Use the screwdriver to loosen screws in positions L1 and L2 at the contactor's GRID inputs.
2. Insert L1 and L2 of the GRID conductors into the GRID input terminals of L1 and L2.
3. Tighten to 2.5Nm.
4. Use screwdriver to secure the GRID EGC to the grounding bus bar.

9.4 LOAD Connection

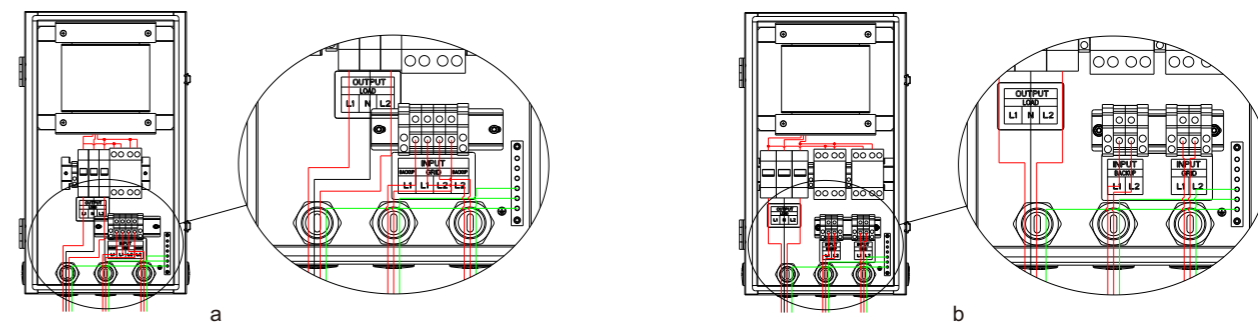

1. Use the screwdriver to loosen the three screws on the LOAD terminals.
2. Insert L1, L2, and N of the LOAD conductors into the L1, L2, and N terminals.
3. Tighten to 3.5Nm.
4. Use screwdriver to secure the LOAD EGC to the grounding bus bar.

Picture above a:ATS 5000T-US,b:ATS 11400T-US

9.5 Checking

Please make sure that all wiring in the ATS-US is tightened.

10. ATS-US usage methods

After connecting the ATS-US internal wire, close the cover and the GRID and EPS end of the ATS-US are respectively connected with the AC GRID and EPS output of inverter, EPS load end access load. Run the system, loaded into normal operation.

11. Trouble shooting

1. In the process of use, if EPS load does not work in on-grid condition, please turn off the inverter and turn off the switch of grid input. Then open the ATS-US cover, check the GRID and EPS LOAD line is connected properly.
2. If there is no power in load in off-grid condition, please turn off the inverter and open the ATS-US cover, check the control line, the EPS wiring and the EPS LOAD wiring is properly.

12. Caution

1. Please use the equipment within the scope of specification. Excessive current or voltage may cause device damage.
 2. To avoid personal injury due to energy hazard, remove wristwatches and jewelry when repairing. Use tools with insulated handles.
 3. The rated power of secondary side L1-N and L2-N could up to 5KVA respectively, and power difference between the two split phases can not exceed 3KW.
 4. Don't connect N of ATS together with N of grid.
 5. Don't connect N of ATS to PE of ATS or PE of grid.
 6. Repair is to be performed only by qualified technical personal authorized by manufacturer.
- The rated balanced power(L-N)means the Load of L1-N and L2-N is equal.
The rated unbalanced power(L-N)means the load of L1-N and L2-N is different.