

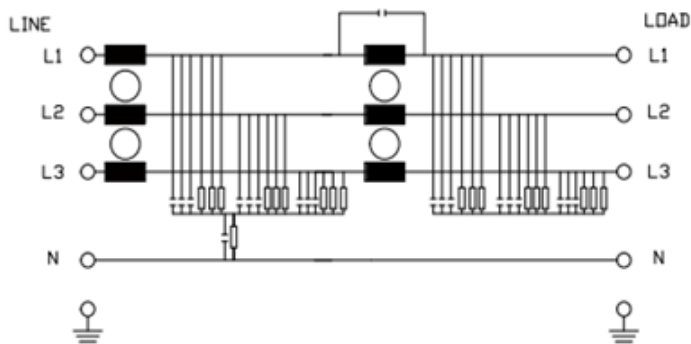

## PLC Line Filter

In commercial applications, the QD-LCF-400-3P Line Filter, manufactured by Astrodyne, separates power line communication domains across the Enphase IQ8P-3P or IQ8H-3P Microinverters installation when multiple Enphase IQ Gateway Commercial 2 are located on a single utility transformer or when site loads generate electrical noise that disrupts communication.

Schematic



Connect both Enphase IQ Gateway Commercial 2 and Enphase IQ8P-3P or IQ8H-3P Microinverters on the array or load side of the filter, and wire the utility feed to the line side of the filter.

# Power Line Filter

## MODEL NUMBER

QD-LCF-400-3P

Three-phase line communication filter, 400 A, suitable for use with IQ8P-3P or IQ8H-3P Microinverters only

## SPECIFICATIONS

Maximum continuous current per line	400 A (temperature adjusted to 65°C)
Maximum voltage	480 VAC +10%
Frequency	50/60 Hz
Power dissipation	75 W max (current dependent)
Ambient temperature range	-40°C to 65°C (-40°F to 149°F)
Weight	31.0 lbs (14.1 kg)
Dimensions	441 mm x 170 mm x 150 mm (17.36" x 6.69" x 5.90")
Phase coupler	Not required
RoHS/Safety	Yes/cURus, EN60939
Terminal style/size	Ground terminal = M10, bus bar = 25 mm with M10 bolt
Typical leakage current	<10 mA (480 V, 50/60 Hz)
Insertion loss (80 kHz–130 kHz)	>50 dB
Impedance (80 kHz–130 kHz)	>100 Ω

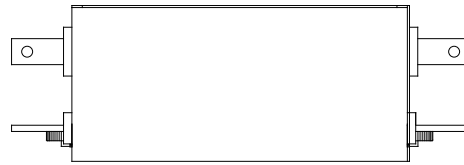

All dimensions are in mm

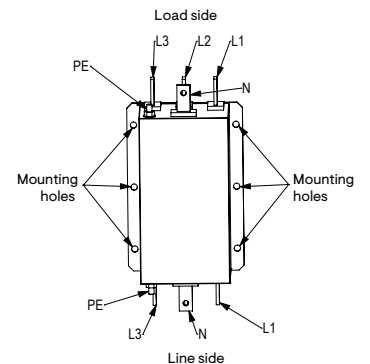
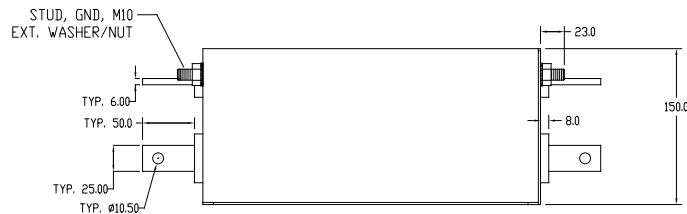
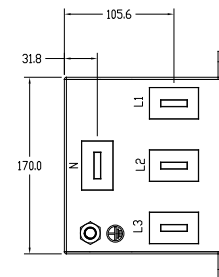
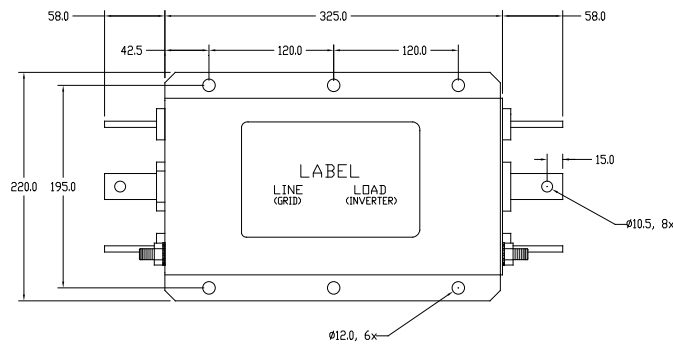
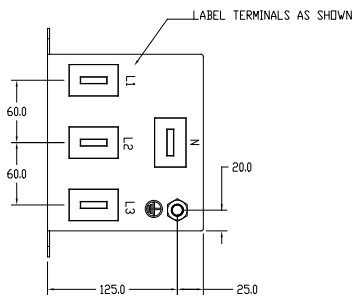

- Recommended torque for M10 terminals is 18 N m (160 in-lb)
- Recommended conductor size for 400 A continuous is 500 kcmil
- Mount in an appropriate enclosure using the mounting holes

# Revision history

REVISION	DATE	DESCRIPTION
DSH-00252-1.0	November 2023	Editorial updates.
		Previous releases.