

## Cabling recommendation

The length and quality of the cable will affect the signal quality. To achieve a good signal quality, observe the following instructions regarding cabling:

- Cross-section: min. 2 x 2 x AWG 24 (2 x 2 x 0,22 mm<sup>2</sup>)
- CAT 5 (shielded)
- UV resistant (for outdoor use only)

We recommend the following SMA cable types:

For installation outdoors: COMCAB-OUTxxx\*

For installation indoors: COMCAB-INxxx\*

\*available in the following lengths xxx=100 m; 328 ft. / 200 m; 656 ft.

/500 m; 1,640 ft. and 1,000 m; 3,280 ft.



## RS485 Cabling Plan



485VERK-TB-AU\_en-14 | Version 1.4



## RS485

The RS485 standard interfaces ensure secure data transmission with a high level of interference resistance over long distances max. 3,930 ft. (max. 1,200 m) between the nodes of the multipoint bus system. The data is transmitted differentially via the voltage difference between the two data cables DATA+ (D+) and DATA- (D-). It is important that all bus nodes share one ground potential.

A ground wire (GND) is used to produce the shared ground potential. The data is transmitted serially and bi-directionally between the bus nodes. All communication buses may receive data, but only one bus node may transmit data at any given moment (half-duplex process).

## Topology

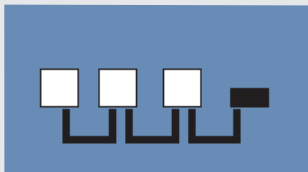

Daisy chain

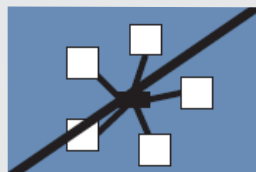

Star network

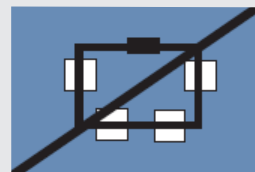

Ring

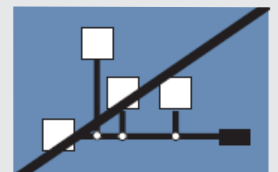

Backbone with stubs

## SMA wiring diagram

Topology	Daisy chain
Max. number of bus nodes	50
Signal biasing	Always effected at the communication device
Max. cable length	3,930 ft. (1,200 m)

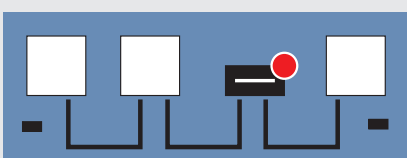
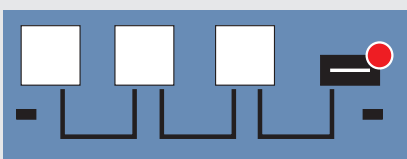

- RS485 bus node  
Sunny Boy, Sunny Tripower,  
Sunny SensorBox, SMA Meteo Station ...
- Communication device  
Sunny WebBox
- Termination
- Signal biasing



## Termination

The RS485 communication bus is terminated on both cable ends with termination resistors. The termination resistors impede reflections on the RS485 communication bus.

## Signal biasing

The signal biasing on the communication device guarantees a defined resting potential on the RS485 communication bus. The resting potential is present when no bus nodes are active.

## Signal allocation

	Signal	RS485 bus node	Sunny WebBox	Sunny SensorBox		RS485-Power Injector	
				IN	OUT	IN	OUT
	+12V*	-	-	+12V	+12V	NC	+12V
	GND	5	5	GND	GND	GND	GND
	Data+	2	2	D+	D+	D+	D+
	Data-	7	7	D-	D-	D-	D-

\* +12V is only used for the Sunny SensorBox and the RS485-Power Injector.

## Sunny WebBox

Sunny WebBox located at end of bus node

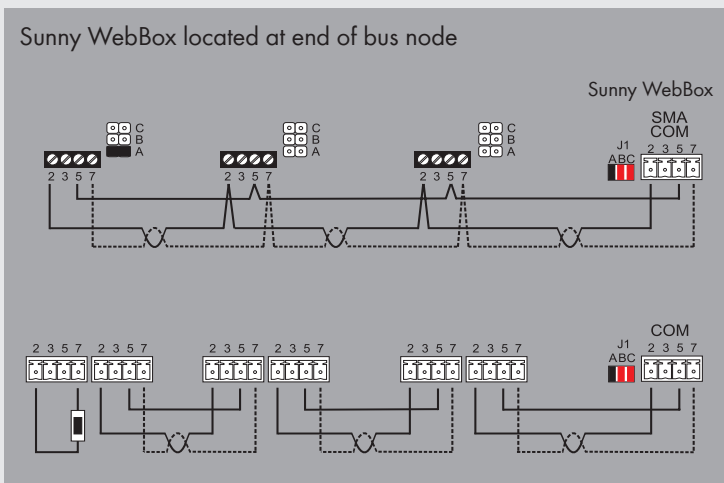

Sunny WebBox located at middle of bus node

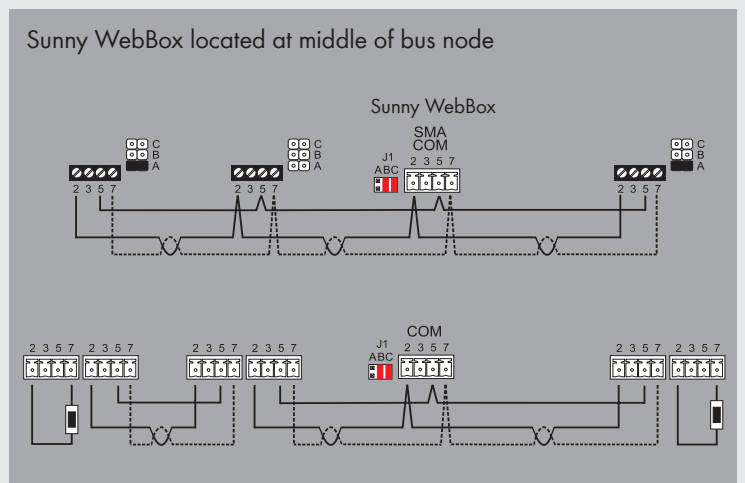

## RS485-Power Injector - Sunny SensorBox

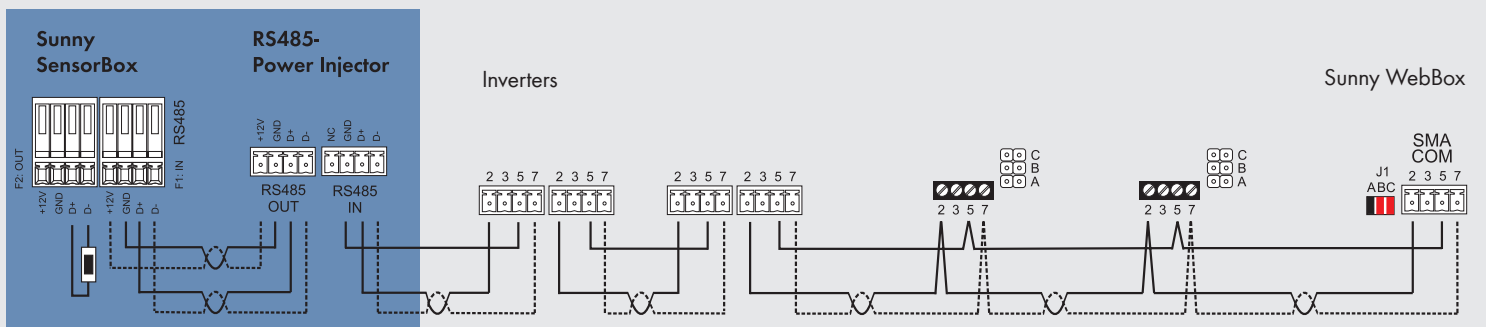

## Legend

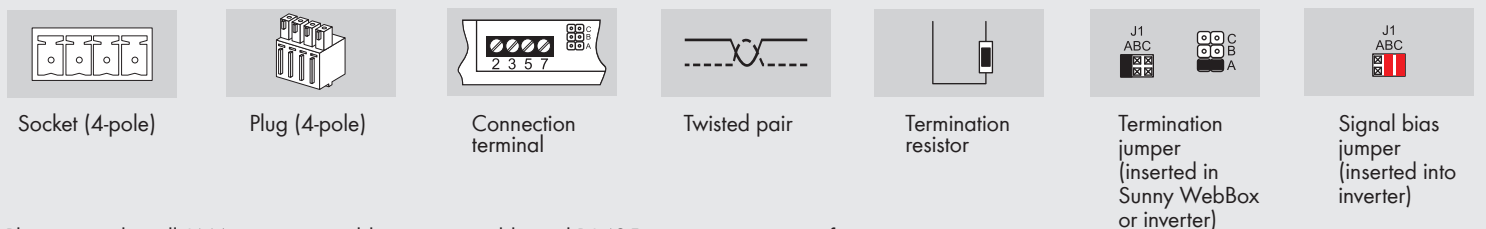

Please note that all SMA inverters would require an additional RS485 communication interface.