



PV Inverter

**Sunny Boy 6000TL-US / 7000TL-US / 8000TL-US /  
9000TL-US / 10000TL-US / 11000TL-US**

**Installation Manual**





Copyright © 2012 SMA America, LLC. All rights reserved.

No part of this document may be reproduced, stored in a retrieval system, or transmitted, in any form or by any means, electronic, mechanical, photographic, magnetic or otherwise, without the prior written permission of SMA America, LLC.

Neither SMA America, LLC nor SMA Solar Technology Canada Inc. makes representations, express or implied, with respect to this documentation or any of the equipment and/or software it may describe, including (with no limitation) any implied warranties of utility, merchantability, or fitness for any particular purpose. All such warranties are expressly disclaimed. Neither SMA America, LLC nor its distributors or dealers nor SMA Solar Technology Canada Inc. nor its distributors or dealers shall be liable for any indirect, incidental, or consequential damages under any circumstances.

(The exclusion of implied warranties may not apply in all cases under some statutes, and thus the above exclusion may not apply.)

Specifications are subject to change without notice. Every attempt has been made to make this document complete, accurate and up-to-date. Readers are cautioned, however, that SMA America, LLC and SMA Solar Technology Canada Inc. reserve the right to make changes without notice and shall not be responsible for any damages, including indirect, incidental or consequential damages, caused by reliance on the material presented, including, but not limited to, omissions, typographical errors, arithmetical errors or listing errors in the content material.

All trademarks are recognized even if these are not marked separately. Missing designations do not mean that a product or brand is not a registered trademark.

The *Bluetooth*<sup>®</sup> word mark and logos are registered trademarks owned by Bluetooth SIG, Inc. and any use of such marks by SMA America, LLC and SMA Solar Technology Canada Inc. is under license.

SMA America, LLC  
3801 N. Havana Street  
Denver, CO 80239 U.S.A.

SMA Solar Technology Canada Inc.  
2425 Matheson Blvd. E  
8th Floor  
Mississauga, ON L4W 5K5  
Canada

## IMPORTANT SAFETY INSTRUCTIONS

### SAVE THESE INSTRUCTIONS

This manual contains important instructions for the following products:



- Sunny Boy

This manual must be followed during installation and maintenance.

The product is designed and tested according to international safety requirements, but as with all electrical and electronic equipment, certain precautions must be observed when installing and/or operating the product. To reduce the risk of personal injury and to ensure the safe installation and operation of the product, you must carefully read and follow all instructions, cautions and warnings in this manual.





### Warnings in this document

A warning describes a hazard to equipment or personnel. It calls attention to a procedure or practice, which, if not correctly performed or adhered to, could result in damage to or destruction of part or all of the SMA equipment and/or other equipment connected to the SMA equipment or personal injury.

Symbol	Description
 <b>DANGER</b>	DANGER indicates a hazardous situation which, if not avoided, will result in death or serious injury.
 <b>WARNING</b>	WARNING indicates a hazardous situation which, if not avoided, could result in death or serious injury.
 <b>CAUTION</b>	CAUTION indicates a hazardous situation which, if not avoided, could result in minor or moderate injury.
<b>NOTICE</b>	NOTICE is used to address practices not related to personal injury.







## Other Symbols in this document

In addition to the safety and hazard symbols described on the previous pages, the following symbol is also used in this manual:

Symbol	Description
	Indicates information that is important for a specific topic or objective, but is not safety-relevant.
	Indicates a requirement for meeting a specific goal.
	Desired result
	A problem that could occur

## Warnings on this product

The following symbols are used as product markings with the following meanings.

Symbol	Description
	<p><b>Warning regarding dangerous voltage</b></p> <p>The product works with high voltages. All work on the product must only be performed as described in the documentation of the product.</p>
	<p><b>Beware of hot surface</b></p> <p>The product can become hot during operation. Do not touch the product during operation.</p>
	<p><b>Observe the operating instructions</b></p> <p>Read the documentation of the product before working on it. Follow all safety precautions and instructions as described in the documentation.</p>
	Transformerless
	UL1741 is the standard applied by Underwriters Laboratories to the product to certify that it meets the requirements of the <i>National Electrical Code</i> <sup>®</sup> , the <i>Canadian Electrical Code</i> <sup>®</sup> CSA C22.1 and IEEE-929-2000. IEEE 929-2000 provides recommendations regarding the proper equipment and functionality necessary to ensure compatible operation when power generation is connected to the utility grid.
	Earth Ground

## General Warnings

### **⚠ WARNING**

#### General Warnings

All electrical installations must be made in accordance with the local and *National Electrical Code*® ANSI/NFPA 70 or the *Canadian Electrical Code*® CSA C22.1. This document does not and is not intended to replace any local, state, provincial, federal or national laws, regulation or codes applicable to the installation and use of the product, including without limitation applicable electrical safety codes. All installations must conform with the laws, regulations, codes and standards applicable in the jurisdiction of installation. SMA assumes no responsibility for the compliance or noncompliance with such laws or codes in connection with the installation of the product.

The product contains no user-serviceable parts.

For all repair and maintenance, always return the unit to an authorized SMA Service Center.

Before installing or using the product, read all of the instructions, cautions, and warnings in this manual.

Before connecting the product to the electrical utility grid, contact the local utility company. This connection must be made only by qualified personnel.

Wiring of the product must be made by qualified personnel only.

# Table of Contents

<b>1</b>	<b>Information on this Manual.</b>	<b>11</b>
1.1	Validity	11
1.2	Target Audience	11
1.3	Storing the Documentation	11
1.4	Additional Information	11
1.5	Nomenclature	11
<b>2</b>	<b>Safety</b>	<b>12</b>
2.1	Intended Use.	12
2.2	Safety Precautions.	15
<b>3</b>	<b>Unpacking and Inspection.</b>	<b>16</b>
3.1	Scope of Delivery	16
3.2	Component Parts of the Sunny Boy	17
3.3	Position of the Stickers.	17
3.4	Identifying the Sunny Boy	18
<b>4</b>	<b>Mounting.</b>	<b>19</b>
4.1	Safety	19
4.2	Requirements for the Mounting Location.	20
4.2.1	Possibilities for Mounting the Wall Mounting Bracket.	23
4.2.2	Mounting the Wall Mounting Bracket.	24
4.3	Mounting the DC Disconnect	25
4.3.1	Mounting the Sunny Boy on a Wall Mounting Bracket	27
<b>5</b>	<b>Electrical Connection</b>	<b>28</b>
5.1	Circuit Diagram with SMA DC Disconnect and Combiner Box	30
5.2	Inserting the Cables in the DC Disconnect	31
5.3	Connection Area of the Sunny Boy.	32
5.4	AC Connection	33

- 5.4.1 Connecting the AC Cables in the DC Disconnect . . . . . 35
- 5.4.2 Connecting the AC Cables in the Sunny Boy . . . . . 37
- 5.5 DC Connection . . . . . 39
  - 5.5.1 DC Cable Requirements . . . . . 40
  - 5.5.2 Connecting the DC Cables in the DC Disconnect . . . . . 40
  - 5.5.3 Connecting the DC cable in the Sunny Boy . . . . . 41
- 5.6 Communication . . . . . 42
- 6 Commissioning . . . . . 43**
  - 6.1 Switching On the Sunny Boy . . . . . 43
  - 6.2 The Sunny Boy Does Not Resume Operation . . . . . 45
- 7 Displays and Messages . . . . . 47**
  - 7.1 Setting the Display Language . . . . . 48
  - 7.2 Display Messages . . . . . 48
  - 7.3 LED Display . . . . . 51
- 8 Opening and Closing . . . . . 55**
  - 8.1 Opening the Sunny Boy . . . . . 55
  - 8.2 Closing the Sunny Boy . . . . . 56
  - 8.3 Opening the DC Disconnect . . . . . 58
  - 8.4 Closing the DC Disconnect . . . . . 59
- 9 Maintenance . . . . . 60**
  - 9.1 Cleaning the Fans . . . . . 60
  - 9.2 Cleaning the Handle Covers . . . . . 62
  - 9.3 Checking the DC Disconnect . . . . . 62
  - 9.4 Checking the Fans . . . . . 63
  - 9.5 Testing and Replacing the Varistors . . . . . 65
    - 9.5.1 DC Varistors . . . . . 65
    - 9.5.2 AC Varistors . . . . . 67



- 10      Decommissioning . . . . . 68**
- 10.1    Dismantling the Sunny Boy and the DC Disconnect . . . . . 68
- 10.2    Packaging the Sunny Boy . . . . . 69
- 10.3    Storage . . . . . 69
- 10.4    Disposal . . . . . 69
- 11      Technical Data . . . . . 70**
- 11.1    Sunny Boy 6000TL-US . . . . . 70
- 11.2    Sunny Boy 7000TL-US . . . . . 72
- 11.3    Sunny Boy 8000TL-US . . . . . 75
- 11.4    Sunny Boy 9000TL-US . . . . . 77
- 11.5    Sunny Boy 10000TL-US . . . . . 80
- 11.6    Sunny Boy 11000TL-US . . . . . 82
- 11.7    DC Disconnect . . . . . 85
- 11.8    Tripping Limits and Tripping Times . . . . . 86
- 11.9    Torque Values and Cable Sizes . . . . . 87
- 12      Spare Parts and Accessories . . . . . 88**
- 13      Compliance Information . . . . . 89**
- 14      Contact . . . . . 90**



# 1 Information on this Manual

## 1.1 Validity

This manual describes the mounting, installation, commissioning and maintenance of the following SMA inverters:

- Sunny Boy 6000TL-US
- Sunny Boy 7000TL-US
- Sunny Boy 8000TL-US
- Sunny Boy 9000TL-US
- Sunny Boy 10000TL-US
- Sunny Boy 11000TL-US

This manual does not contain any information on the devices that are connected to the Sunny Boy. Information concerning the connected equipment is available from the manufacturer of the equipment.

## 1.2 Target Audience

This manual is for electrically qualified persons. Electrically qualified persons have received training and have demonstrated skills and knowledge in the construction and operation of this device. Electrically qualified persons are trained to deal with the dangers and hazards involved in installing electrical installations.

## 1.3 Storing the Documentation

Store all manuals for the Sunny Boy in such way that they may be accessed at any time.

## 1.4 Additional Information

Additional information on specific topics can be found in the download area at [www.SMA-America.com](http://www.SMA-America.com).

## 1.5 Nomenclature

In this document, SMA America Production, LLC and SMA Solar Technology Canada Inc. will be referred to as SMA.

## 2 Safety

### 2.1 Intended Use

The Sunny Boy is a PV inverter which converts the DC current of the PV array to AC current and feeds it into the power distribution grid. The Sunny Boy is suitable for use with fuel cells, small wind turbine systems, and other DC current sources. You can use the AC electricity generated as follows:

- Household grid: Energy flows into the household grid. The loads connected, for example household devices or lighting, consume the energy. The energy left over is fed into the power distribution grid. When the Sunny Boy is not generating any energy, e.g. at night, the loads that are connected are supplied by the power distribution grid.
- The Sunny Boy does not have its own energy meter. When energy is being fed into the power distribution grid, the energy meter runs in reverse.
- Power distribution grid: Energy is fed directly into the power distribution grid. The Sunny Boy is connected to a separate energy meter. Depending on the electric utility company, you will be remunerated accordingly for the energy generated.
- Stand-alone grid: The Sunny Boy is connected to a stand-alone grid. A stand-alone grid is a grid that is not connected to a power distribution grid. The Sunny Boy needs a grid-forming generator, for example, a Sunny Island, in order to function. The energy generated is consumed directly on site, surplus energy can be stored in batteries.

### Interconnection Code Compliance

The Sunny Boy has been checked by the certification body and certified according to the guidelines in UL 1741 Static Inverters and Charge Controllers for use in Photovoltaic Power Systems, IEEE 929-2000 Recommended Practice for Utility Interface of Photovoltaic Systems, and IEEE 1547 Standard for Interconnecting Distributed Resources with Electric Power Systems.



UL 1741 is the standard used for the Sunny Boy by the certification body in order to certify that it complies with the regulations of the *National Electrical Code*<sup>®</sup> and IEEE 929-2000. IEEE 929-2000 states recommendations regarding the appropriate equipment and functionality that is required to guarantee fault-free operation when the power generation is connected to the power distribution grid.

The Sunny Boy is also certified in accordance with *Canadian Electrical Code*<sup>®</sup> CSA C22.2 NO. 107.1-01 (General Use Power Supplies).



**Prior to designing and installing your PV plant, contact the local grid operator or the responsible authority.**

## Principle of a PV Plant with a Sunny Boy

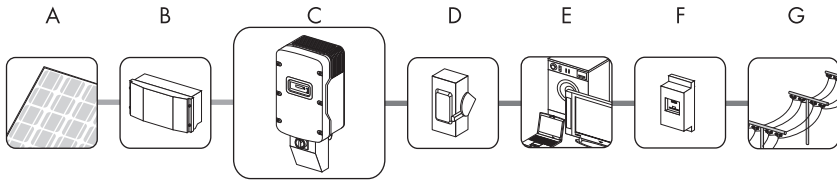

Position	Description
A	PV modules
B	Sunny Boy Combiner Box
C	Sunny Boy with SMA DC Disconnect
D	AC load circuit breaker
E	Loads
F	Energy meter
G	Power distribution grid

The Sunny Boy may only be operated with PV arrays (modules and cabling) that have protective insulation. Do not connect any energy sources other than PV modules to the Sunny Boy.

### **i** Leading Leakage Currents

PV modules with large capacities relative to ground, such as thin-film PV modules, may only be used if their coupling capacity does not exceed 2  $\mu\text{F}$ .

During feed-in to the grid, a leakage current flows from the cells to ground. The amount of current depends on how the modules are installed and on the weather. This leakage current may not exceed 50 mA since otherwise the inverter will automatically disconnect from the grid.

## PV plant design

When designing the PV plant, ensure that the values comply with the permitted operating range of all component parts at all times. Use the free of charge "Sunny Design" at [www.SMA-America.com](http://www.SMA-America.com) to design your PV plant.

### **i** The Sunny Boy 6000TL-US, 7000TL-US, 8000TL-US, 9000TL-US, 10000TL-US and 11000TL-US is a transformerless inverter.

It has no galvanic isolation.

The PV modules must be rated for at least the maximum PV plant voltage.

## Grounding the PV modules

This Sunny Boy is a transformerless inverter. That is why it has no galvanic isolation. Do not ground the DC electric circuits of the PV modules connected to the Sunny Boy. Only ground the mounting frame of the PV modules.

If you connect grounded modules to the Sunny Boy, the error message F-Riso is displayed. The DC electric circuit is connected to the AC grid during operation.

## Fuses

The Sunny Boy and the DC-Disconnect do not contain string fuses.

According to the *National Electrical Code*<sup>®</sup> of 2008, Section 690.35, string fuses are necessary in order to protect the PV plant against reverse currents.

## Arc-Fault Circuit Interrupter AFCI

Only the following Sunny Boy types are equipped with an automatic arc-fault circuit interrupter (AFCI):

- SB 6000TLUS-12
- SB 7000TLUS-12
- SB 8000TLUS-12
- SB 9000TLUS-12
- SB 10000TLUS-12
- SB 11000TLUS-12

The 2011 edition of the *National Electrical Code*<sup>®</sup>, Section 690.11, stipulates that newly installed PV plants attached to a building must be fitted with a means of detecting and disconnection of serial electric arcs (AFCI) on the PV side.

An electric arc with a power of 300 W or greater must be interrupted by the AFCI in the time specified by UL 1699B. A tripped AFCI may only be reset manually.

The arc-fault circuit interrupter (AFCI) can be deactivated in the "Installer" mode via the communication device if this function is not desired.

## 2.2 Safety Precautions

### DANGER

#### High voltages in the inverter

Electric shock when touching live components.

- Prior to performing any work on the inverter, disconnect the inverter from any voltage sources.
- Only connect the inverters as described in this manual.
- Only electrically qualified persons may work on the inverter.

### CAUTION

#### The inverter can become hot during operation

- Burn injuries may be possible when touching the enclosure.
- During operation, touch the enclosure lid only.

#### The Sunny Boy may down over due to inappropriate transport

Contusions or bone fractures due to the heavy weight of the Sunny Boy.

- Prior to transporting the Sunny Boy, take its weight of 77 lb. (35 kg) into consideration.
- Use suitable lifting techniques for the transport.

### 3 Unpacking and Inspection

Check the delivery for completeness and any visible external damage. Contact your SMA specialty retailer or SMA if the delivery is incomplete or you find any damage.

Contact information is provided in the "Contact" Section, page 14 "Contact", page 90.

If it is necessary to send the Sunny Boy back, use the original packaging.

#### 3.1 Scope of Delivery

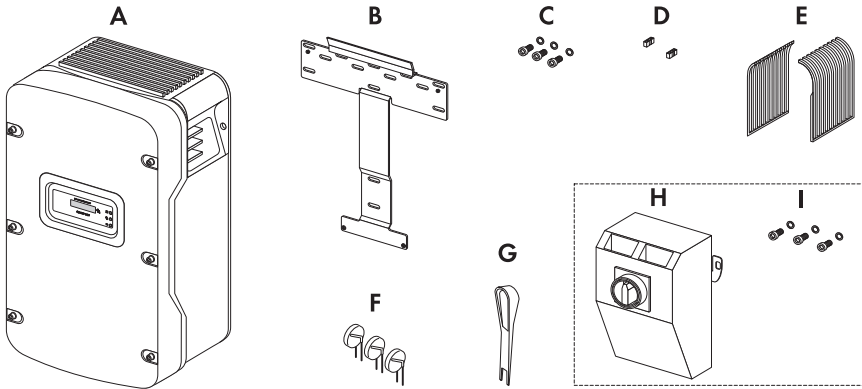

Position	Quantity	Description
A	1	Sunny Boy
B	1	Wall-mounting bracket
C	1	Spare screw and spare conical spring washers for closing the Sunny Boy lid
	2	Screws and washers for fastening the Sunny Boy to the wall-mounting bracket
D	2	Spare jumpers for fan test
E	2	Handle covers (left and right)
F	3	DC varistors*
G	1	Insertion tool for DC varistors*
H	1	DC Disconnect
I	1	Screw and washer for closing the DC Disconnect lid
	2	Screws and washers for fastening the DC Disconnect to the wall-mounting bracket

\* only SB 6000TLUS-12/SB 7000TLUS-12/SB 8000TLUS-12/SB 9000TLUS-12/SB 10000TLUS-12/SB 11000TLUS-12

**i** If not ordered differently, the SMA Sunny Boy Combiner Box is included in the scope of delivery as a standard feature.



### 3.2 Component Parts of the Sunny Boy

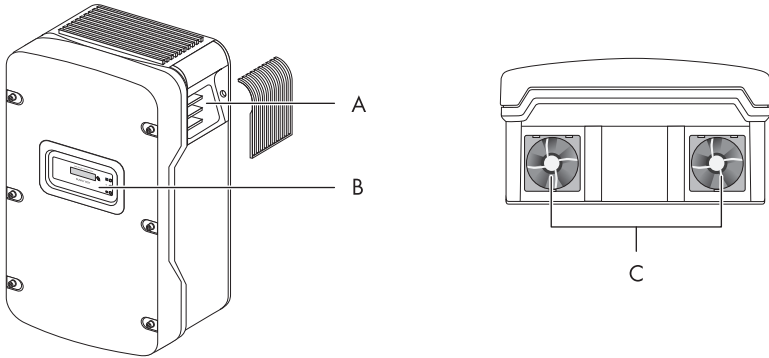

Position	Description
A	Ergonomic handle
B	Display
C	Fan

### 3.3 Position of the Stickers

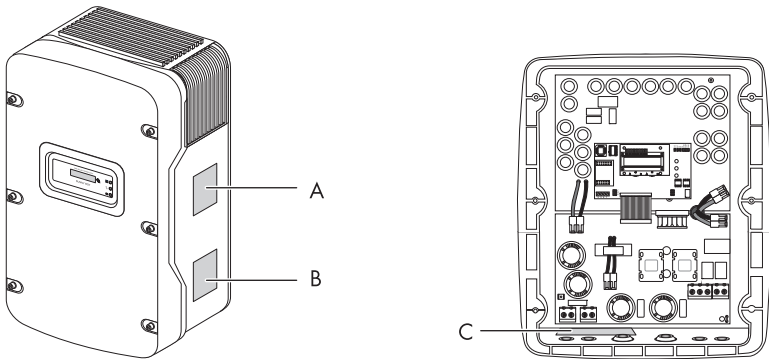

Position	Description
A	Type label
B	General warning sticker
C	Warning sticker for the DC connection

### 3.4 Identifying the Sunny Boy

You can identify the Sunny Boy by the type label. It is on the right side of the enclosure.

The type label shows:

- The serial number (Serial No.).
- The product type (Type/Model).
- The device-specific characteristics.



## SUNNY BOY

Model  
**SB xxxxxxxx**

Serial No.  
**XXXXXXXXXX**

Date of manufacture **xx/xxxx**

Max. continuous output Power* <b>xxxxx Wac</b>		
Operating voltage range (Vac)*		
MIN <b>xxx</b>	NOMINAL <b>xxx</b>	MAX <b>xxx</b>

Operating frequency range (Hz)*		
MIN <b>xx.x</b>	NOMINAL <b>xx.x</b>	MAX <b>xx.x</b>

Max. continuous output current\* **xx Aac**

Output power factor **x**

Range of input operating voltage **xxx-xxx Vdc**

MPPT Range of input operating DC voltage\*  
**xxx-xxx Vdc**

Max. operating current **xx Adc**

This unit contains a Residual Current Monitor, Isolation Monitor and Interrupteur

ENCLOSURE Type 3R (IP54)

\*For more details and for tightening torque, allowable wire size and type see the Operator's Manual

Section 1 of 2





**US LISTED**

Utility interactive inverter  
LISTED UL 1741 36AN

Utility Interactive 1-Phase Inverter



Tested To Comply  
With FCC Standards  
FOR HOME AND OFFICE USE

## 4 Mounting

### 4.1 Safety

#### DANGER

##### **Danger to life due to fire or explosions**

With electrical devices, there is always a certain danger that a fire may break out.

- Do not install the inverter in the vicinity of combustible materials.
- Do not install the inverter in potentially explosive atmospheres.

#### CAUTION

##### **The Sunny Boy may fall down due to inappropriate mounting**

Contusions or bone fractures due to the heavy weight of the Sunny Boy.

- When mounting the Sunny Boy, take its weight of 77 lb. (35 kg) into consideration.
- Use appropriate mounting material for the mounting location of the inverter:
  - For mounting on plasterboard, do not use hollow wall anchors or toggle bolts.
  - Wooden supporting posts must be present behind the installation points on plasterboard.
- Use suitable lifting technique when mounting.

##### **The inverter can become hot during operation**

Burn injuries may be possible when touching the enclosure.

- Install the inverter in such a way that it cannot be touched accidentally.

## 4.2 Requirements for the Mounting Location

### Requirements

- The installation method and mounting location must be suitable for the weight and dimensions of the Sunny Boy (see Section 11 "Technical Data", page 70).
- Note the dimensions of the DC Disconnect (4.3 "Mounting the DC Disconnect", page 25).
- Mount the inverter on a stable surface.
- The mounting location must be accessible at all times.

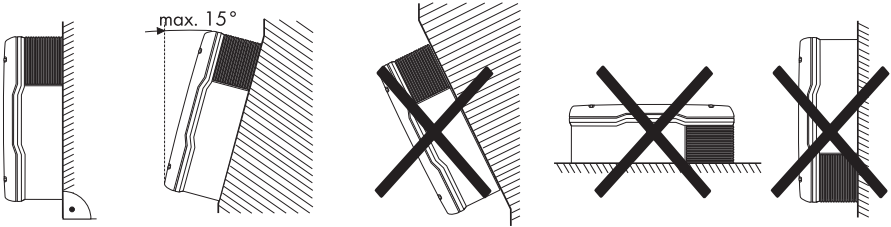

- Mount vertically or tilted backward at max. 15°.
- The connection area must point downward.
- Do not install the inverter tilting forward.
- Do not install the inverter horizontally.
- Install the inverter at eye level in order to be able to read out the operating state at any time.
- The ambient temperature must be in a permissible range ("Technical Data" on page 70).
- Do not expose the inverter to direct sunlight.
- In the living area, do not mount inverters on a plasterboard wall or similar wall.

The Sunny Boy may emit noises when in use which can be regarded as a nuisance.

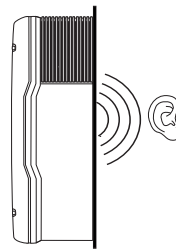

- Observe recommended clearances to walls, other inverters or other objects. As a result, sufficient heat dissipation is ensured.

**i** The *National Electrical Code*® may stipulate greater clearances (see *National Electrical Code*®, Section 110.26). Installations in Canada must be carried out in accordance with the applicable Canadian standards.

- If several inverters are mounted in areas with high ambient temperatures, increase the clearances and ensure a sufficient fresh-air supply. Thus, you will prevent the inverter power from being reduced due to too high temperatures.

**Recommended clearances**

Position	Clearance
Top	12 in. (300 mm)
Bottom	12 in. (300 mm)
Left	12 in. (300 mm)
Right	12 in. (300 mm)
Front	2 in. (50 mm)

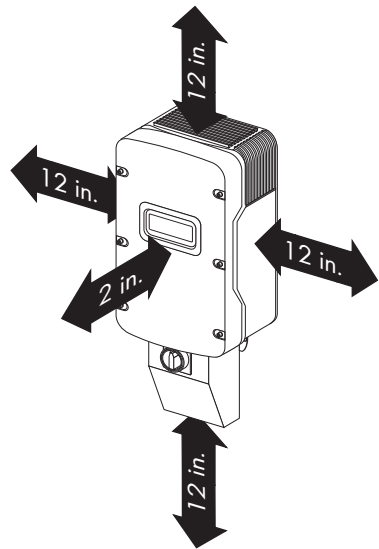

**i** **If the Sunny Boy is installed outdoors**

- Observe minimum clearance to the ground of 36 in. (900 mm).

### Dimensions of the Wall Mounting Bracket

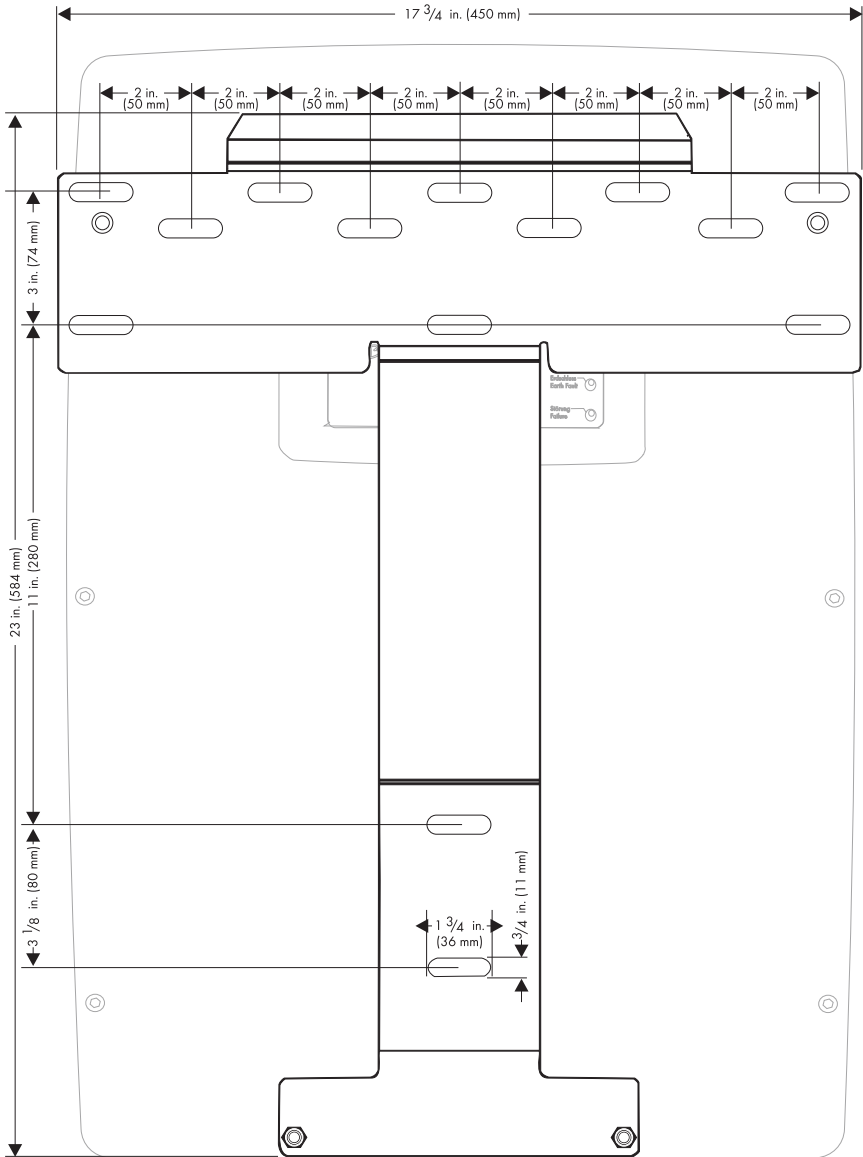

## 4.2.1 Possibilities for Mounting the Wall Mounting Bracket

### Mounting on a Stone Wall

Attach the wall mounting bracket using at least 3 screws. The position of the screws on the wall mounting bracket is as follows:

- 1 screw on the upper left side.
- 1 screw on the upper right side.
- 1 screw below

Mount the wall mounting bracket as described in Section 4.2.2 "Mounting the Wall Mounting Bracket", page 24.

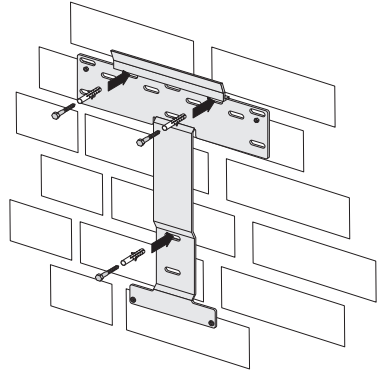

### Mounting on a Wooden Wall with Supporting Post or on a Pillar

Attach the wall mounting bracket using at least 3 screws. The position of the screws on the wall mounting bracket is as follows:

- 2 screws at the upper middle.
- 1 screw below

Mount the wall mounting bracket as described in Section 4.2.2 "Mounting the Wall Mounting Bracket", page 24.

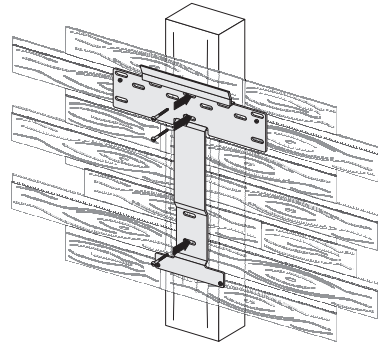

### Mounting on a Wooden Wall with Two Supporting Posts

Attach the wall mounting bracket using at least 4 screws. The position of the screws on the wall mounting bracket is as follows:

- 2 screws on the upper left side.
- 2 screws on the upper right side.

Use the four outer mounting holes on the left and right sides of the wall mounting bracket.

Mount the wall mounting bracket as described in Section 4.2.2 "Mounting the Wall Mounting Bracket", page 24.

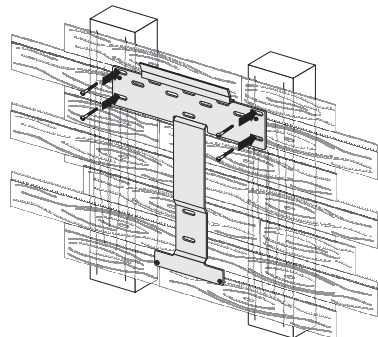

## 4.2.2 Mounting the Wall Mounting Bracket

1. Position the wall mounting bracket at the installation location. If possible, select eye level.
2. Align the wall mounting bracket with a spirit level. The bottom end of the wall mounting bracket reaches approximately to the bottom corner of the inverter.

### 3. **WARNING**

#### **Electric shock due to damaged electric cables**

Electric cables may be located behind the installation points which can be damaged when mounting the inverter.

- Ensure that no electric cables are located behind the installation points.
4. Use the wall mounting bracket as a template. Mark at least 3 holes in the horizontal or vertical position of the wall mounting bracket (see Section 4.2.1 "Possibilities for Mounting the Wall Mounting Bracket", page 23).
  5. Remove the wall mounting bracket and drill the holes at the markings.



The diameter of the drill holes must correspond to the fasteners that you use for mounting the inverter.

#### **Mounting on a concrete wall**

- The hole diameter must be the same as the outer diameter of the screw anchors.
- Insert suitable screw anchors into the drill holes.

#### **Mounting on a wall with wooden support posts**

The hole diameter must correspond to the screw diameter used. The screws should be stainless steel. The diameter of the screws must correspond to the diameter of the holes in the wall mounting bracket. The screws must be long enough to reach a depth in the wall of 1 1/2 in.

6. Insert the screws into the drill holes through the holes in the wall mounting bracket.
7. Tighten the screws clockwise until the wall mounting bracket hangs securely on the wall.



## 4.3 Mounting the DC Disconnect

### Inserting the DC varistors

- i** The supplied DC varistors must only be used for the following inverter types:  
SB 6000TLUS-12/SB 7000TLUS-12/SB 8000TLUS-12/SB 9000TLUS-12/  
SB 10000TLUS-12/SB 11000TLUS-12.

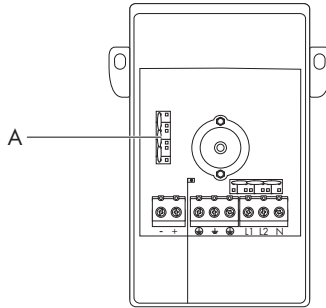

Position	Description
A	Terminals for DC varistors

1. Open the DC disconnect as described in Section 8.3 "Opening the DC Disconnect", page 58.
2. Equip the 3 terminals (A) with DC varistors:

- Insert the insertion tool into the rectangular opening of the terminal.

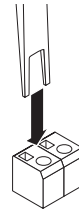

- Insert the DC varistor into the terminal.

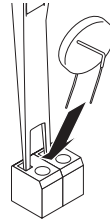

- Pull the insertion tool out of the rectangular opening of the terminal.

3. Ensure that all DC varistors in the terminals are securely in place.
4. Close the DC disconnect as described in Section 8.4 "Closing the DC Disconnect", page 59.

## Dimensions of the SMA DC Disconnect

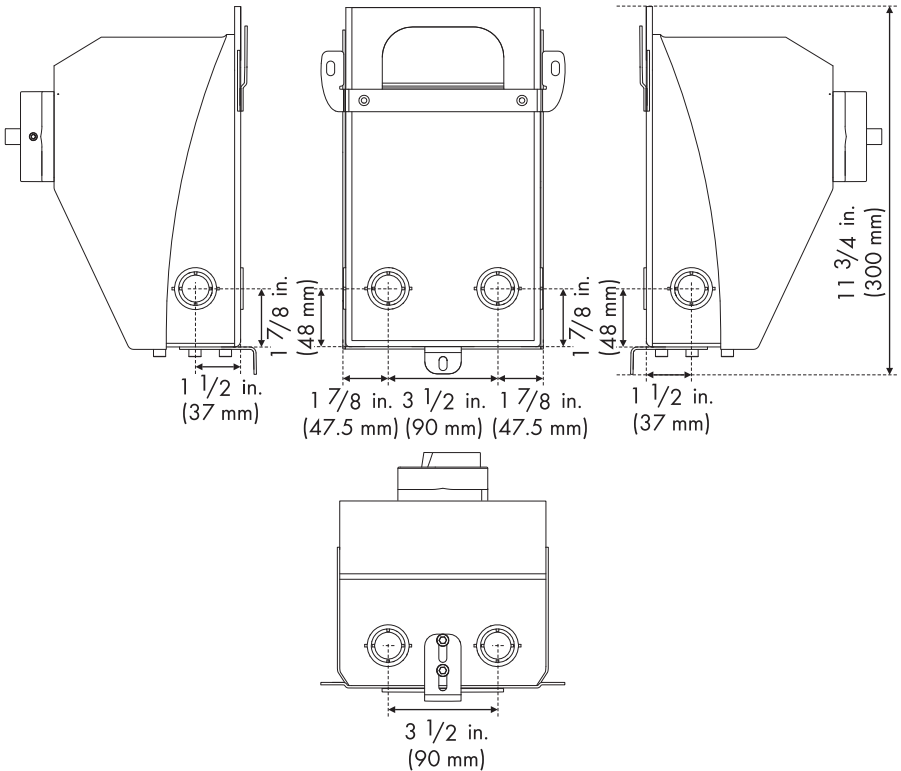

## Mounting the SMA DC Disconnect to the Wall

Attach the SMA DC Disconnect to the two lower holes of the wall-mounting bracket, using two screws and washers provided.

1. Place the screws and the washers in the holes in the fastening tabs on the DC Disconnect. The teeth on the washers must lie against the fastening tabs of the DC Disconnect.
2. Place the SMA DC Disconnect against the wall mounting bracket.
3. Tighten the screws with 44 in.-lb. (5 Nm) torque.

- The SMA DC Disconnect is mounted.

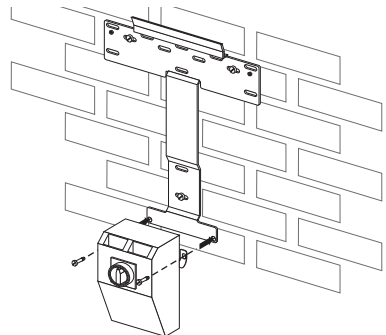

### 4.3.1 Mounting the Sunny Boy on a Wall Mounting Bracket

1. Remove the handle covers on the right and left side of the Sunny Boy.

2. **CAUTION**

**The Sunny Boy may fall down due to inappropriate mounting**

Contusions or bone fractures due to the heavy weight of the Sunny Boy.

- Transport the Sunny Boy between two persons, using the side handles above and below.

or

Put a steel bar with a maximum diameter of  $1\frac{1}{8}$  in. (30 mm) through the enclosure opening above and transport it between two people.

3. Hook the Sunny Boy with the enclosure opening onto the rear panel in the wall mounting bracket. The Sunny Boy must be seated on the middle of the wall mounting bracket.

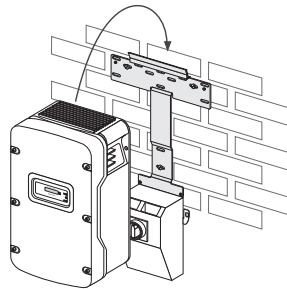

4. Screw the Sunny Boy onto the wall mounting bracket on both sides with the screws supplied.
5. Tighten the screws clockwise with a tightening torque of 44 in-lb. (5 Nm).

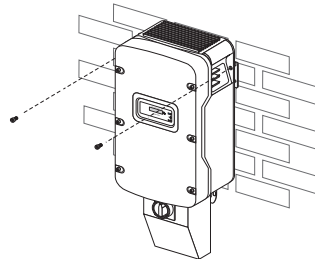

6. Plug handle covers on the handles.

To help you identify the sides, the ventilation grids are marked "rechts/right" and "links/left" on the inside.

The ventilation grids prevent dirt and insects from entering the inverter and can be reordered from SMA if required. See Section 12 "Spare Parts and Accessories", page 88

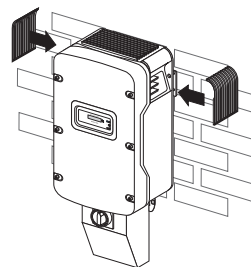

## 5 Electrical Connection

### **⚠ DANGER**

#### **High voltages on the AC and DC cables**

Risk of death or serious injury due to electric shock.

- Only connect the inverters as described in this manual.
- Only electrically qualified persons may work on the inverter.

### **NOTICE**

#### **Ingress of moisture when mounting and installing the Sunny Boy**

Potential damage to the Sunny Boy.

- For inserting the conduits into the enclosure and the DC Disconnect, only use UL-certified rainproof sleeves or waterproof sleeves that fulfill UL 514B.
- Do not open the Sunny Boy in the event of rain or a high level of humidity (>95%).

#### **Damage to the seal of the enclosure lid during frost**

When opening the Sunny Boy during frost, the seal of the enclosure lid can be damaged. There may be an ingress of moisture damaging the Sunny Boy.

- Do not open the Sunny Boy when the outdoor temperature is below 23°F ( - 5°C).

#### **Electrostatic discharges through touching component parts**

Potential damage to the Sunny Boy.

- Ground yourself before touching any electronic component.

#### **Ground faults, unreliable and highly resistive connections due to *Wire Nuts*<sup>®</sup>**

Potential damage to or failure of the Sunny Boy.

- Do not use *Wire Nuts*<sup>®</sup>.



### **Electrical Installations**

All electrical installations must be carried out in accordance with the electrical standards applicable on-site and the *National Electrical Code*<sup>®</sup> ANSI/NFPA 70. Installations in Canada must be carried out in accordance with the applicable Canadian standards.

Before connecting the inverter to the power distribution grid, contact your local electric utility company. This connection may be made only by electrically qualified persons.

## AC Grounding

### **i** The AC outputs and the neutral conductors are not bonded to ground

The Sunny Boy must be connected to the AC grounding conductor of the power distribution grid via the ground terminal (PE) (see Section 5.3 "Connection Area of the Sunny Boy", page 32).

The AC input and AC output circuits are isolated from the enclosure and system grounding, if required by Section 250 of the National Electrical Code, ANSI/NFPA 70, is the responsibility of the installer.

## PV Grounding

The Photovoltaic System Grounding shall be installed per the requirements of Sections 690.41 through 690.47 of the National Electrical Code, ANSI/NFPA 70 and is the responsibility of the installer.

The grounding conductor in the framework of the PV array must be connected to the PV grounding conductor and the DC grounding conductor (see Section 5.3 "Connection Area of the Sunny Boy", page 32). The cross-section of the grounding conductor corresponds to the cross-section of the largest conductor in the DC system.

## DC Grounding Conductor

A DC grounding conductor may be required by the Authority Having Jurisdiction (AHJ). Use the terminal block for the PV grounding conductor and DC grounding conductor (see Section 5.3 "Connection Area of the Sunny Boy", page 32).

### 5.1 Circuit Diagram with SMA DC Disconnect and Combiner Box

**i** The DC Disconnect supplied must be used for the operation of the Sunny Boy.

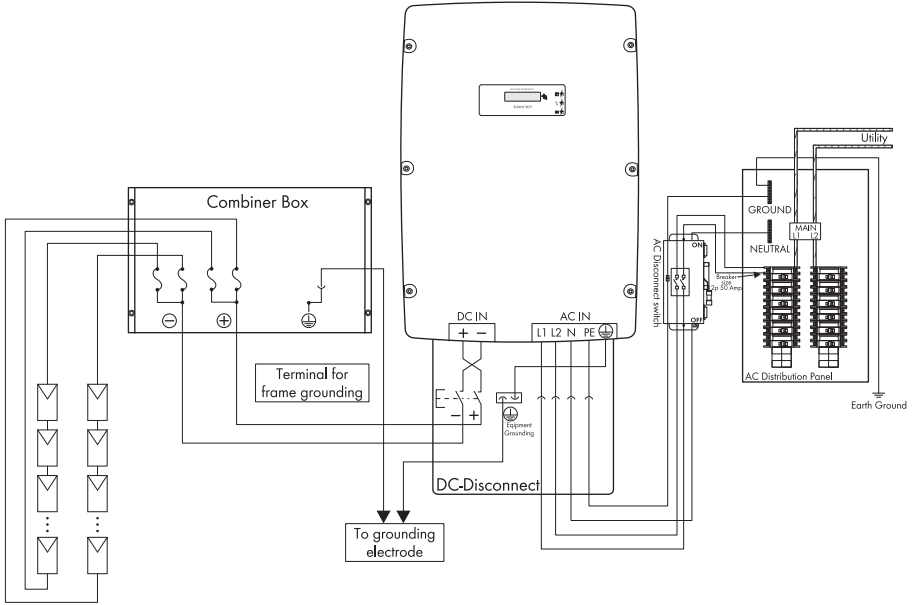

## 5.2 Inserting the Cables in the DC Disconnect

1. Open the DC Disconnect (see Section 8.3 "Opening the DC Disconnect", page 58).
2. Break out the knockout openings for the AC and DC cables. Use separate conduits for the AC and the DC cables.

3. **NOTICE**

**Ingress of moisture in the DC disconnect due to enlarged knockout openings**

Damage to the DC disconnect is possible.

- Do not enlarge the knockout openings.

4. Insert the cable gland in the knockout opening.
5. Plug the conduit into the gland and tighten the gland.

6. **⚠ DANGER**

**High voltages on the AC and DC cables**

Death or serious injuries when touching the voltage-conducting cables.

7. Switch off the main switch in the switch cabinet.
  8. Cover the PV modules with opaque material.
  9. Pull the AC and DC cables through the conduit in the DC Disconnect.
- The cables have been inserted into the DC Disconnect.

### 5.3 Connection Area of the Sunny Boy

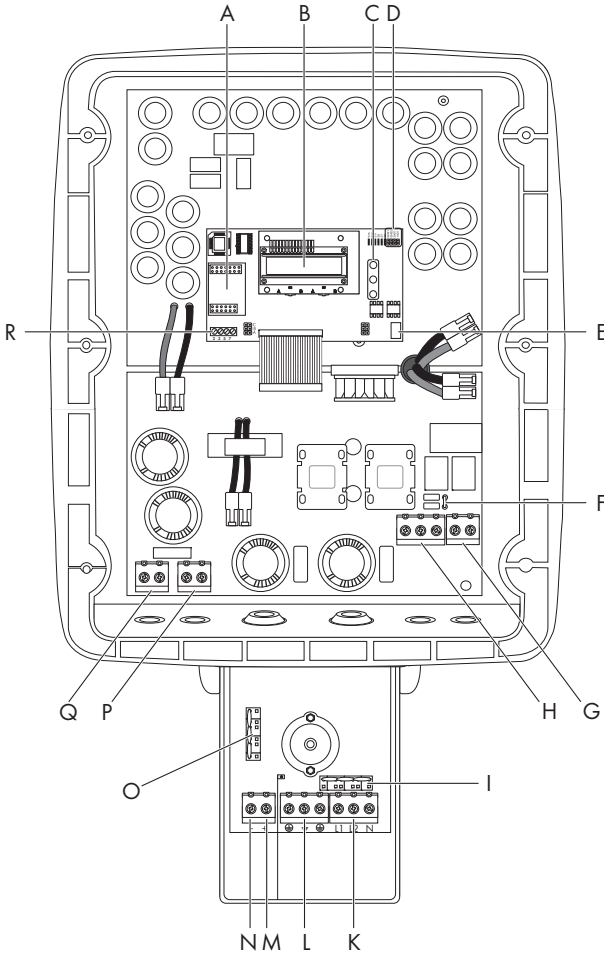

Position	Description
A	Socket for optional communication Piggy-Back (RS485 or wireless)
B	Display
C	Status LEDs
D	Jumper position for verifying the operation of the fans
E	Power Balancer terminal
F	Flat connection for grounding the cable shield for communication
G	Sunny Boy: Ground terminal (PE)



Position	Description
H	Sunny Boy: Output AC line terminals (N, L1 and L2)
I	AC varistor terminal with AC varistors
K	SMA DC Disconnect: Output AC line terminals (N, L1 and L2)
L	SMA DC Disconnect: Grounding electrode terminal for the connection of: <ul style="list-style-type: none"> <li>• Grounding electrode conductor</li> <li>• DC equipment grounding</li> <li>• AC equipment grounding</li> </ul>
M	SMA DC Disconnect: DC+ terminal
N	SMA DC Disconnect: DC – terminal
O	DC varistor terminal with DC varistors*
P	Sunny Boy: DC – terminal
Q	Sunny Boy: DC+ terminal
R	Terminal for optional communication (RS485)

\* only SB 6000TLUS-12/SB 7000TLUS-12/SB 8000TLUS-12/SB 9000TLUS-12/SB 10000TLUS-12/SB 11000TLUS-12

## 5.4 AC Connection

### ⚠ CAUTION

#### Danger of fire

Overcurrent may lead to a cable fire.

- Protect the electrical installation on the AC side. Observe the maximum fuse sizes of the inverter types (see 11 "Technical Data", page 70).
- Do not connect more than 1 inverter to 1 miniature circuit-breaker..
- Install a separate miniature circuit-breaker for each load. Do not connect any branch circuit wires to the miniature circuit-breakers.

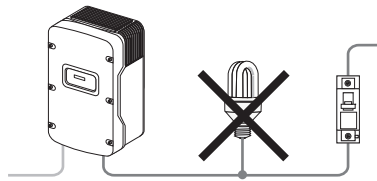

### **i** Electrical Installations

Perform all electrical installations in accordance with all electrical standards applicable locally and the *National Electrical Code*® (NE, ANSI/NFPA 70).

See *National Electrical Code*®, Section 690-64(b) (2).

For installations in Canada, observe the applicable Canadian standards.

### System configuration

The following table shows the possible system configurations for the inverter types:

Inverter type	Voltage	
	208 V WYE	240 V Split Phase
SB xxxxTLUS-10	✓	-
SB xxxxTLUS-12	✓ *	✓

\*not SB 11000TLUS-12

**i** A neutral conductor must be connected to the inverter in either grid situation.

### AC cable requirements

The cable must be dimensioned in accordance with the local and national directives for the dimensioning of cables. The requirements for the minimum conductor cross-section derive from these directives. Influencing factors for cable dimensioning are, among others, the following: nominal AC current, type of cable, cable length, routing method, cable bundling, ambient temperature and maximum desired line losses.

**i** Only use solid wire or stranded wire

- Do not use fine-wire strands.

#### Ambient temperature

The higher the ambient temperature, the higher the power losses.

- Use cables with large cable cross-sections in installation sites with high ambient temperatures.

#### Routing method

The cables heat up during operation. If there are several cables in a conduit, the temperature of all cables increases.

- Use cables with a large cross-section if you lay several cables in one conduit.

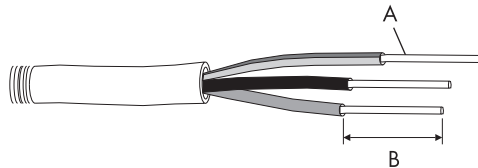

Position	Name	Value
A	Conductor cross-section	6 to 2 AWG (16 to 35 mm <sup>2</sup> )
B	Stripping insulation	3/4 in.(18 mm)

## Load Disconnection Unit

Install a separate miniature circuit-breaker for each inverter, in order that the inverter can be safely disconnected under load. See the technical data (11 "Technical Data", page 70) for the maximum permissible rating.

### NOTICE

#### Screw-type fuse elements as load disconnection unit

The Sunny Boy can be damaged during isolation under load.

- Use a miniature circuit-breaker or listed switch-disconnector as load disconnection unit.
- Do not use a screw-type fuse element as switch-disconnector.

## 5.4.1 Connecting the AC Cables in the DC Disconnect

1. Open all AC and DC circuit breakers or load-disconnecting switches.
2. Open the main fuse in the fuse box.
3. Ensure that there is no voltage between the fuse output and the ground bar. Use a multimeter. The voltage must be 0 V.
4. Open the DC disconnect as described in section 8.3 "Opening the DC Disconnect", page 58.
5. Remove a suitable knockout opening on the bottom side of the DC disconnect.
6. Lay a cable conduit from the fuse box to the DC disconnect (see chapter 5.2 "Inserting the Cables in the DC Disconnect", page 31).
7. Lead the AC cable through the cable conduit from the inside of the fuse box into the inside of the DC Disconnect.

### Open terminals fully before insertion of the cables.

8. Connect the AC device grounding conductor to the PE terminal labeled  in the DC Disconnect.

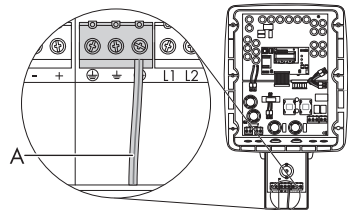

9. Connect conductor L1 (AC conductor 1 or UNGROUNDED) to terminal L1.

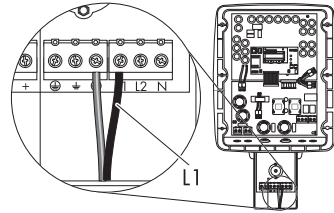

10. Connect conductor L2 (AC conductor 2) to terminal L2.

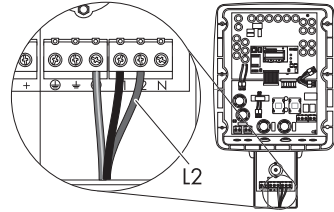

11. Connect conductor N (AC conductor N) to terminal N.

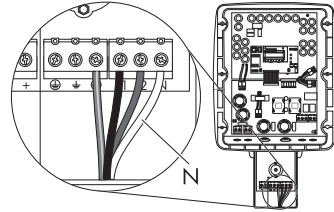

12. Tighten the cables with a torque of 40 in-lb. (4.5 Nm).
13. Check that all terminals have the correct wiring and that the cables are secure.
- The AC cables are connected in the DC Disconnect.

## 5.4.2 Connecting the AC Cables in the Sunny Boy

1. Open the Sunny Boy as described in Section 8.1 "Opening the Sunny Boy", page 55.
2. Feed the cable through the rubber grommet into the inverter.

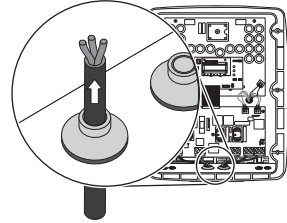

3. Pull the cable back slightly so as to seal the rubber grommet.

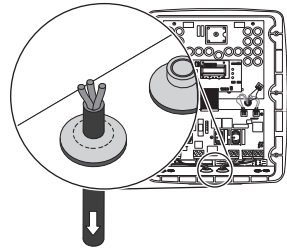

4. Connect the green-yellow cable of the DC Disconnect to the terminal labeled  $\oplus$ .

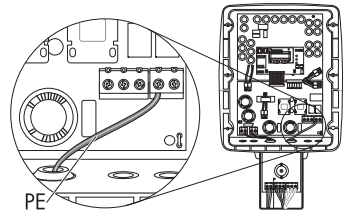

5. Connect the white cable of the DC Disconnect to the terminal labeled N.

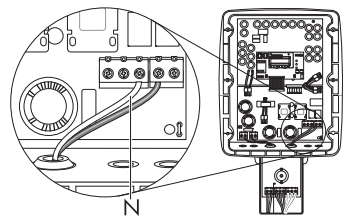

6. Connect the black cable of the DC Disconnect to the terminal labeled L1.

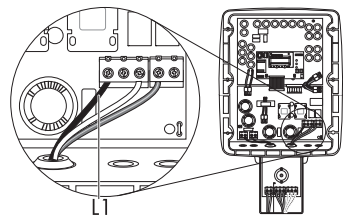

7. Connect the red insulated conductor to the terminal labeled L2.

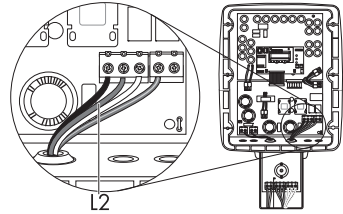

8. Tighten the cables with a torque of 40 in-lb. (4.5 Nm).
  9. Check that all terminals have the correct wiring and that the cables are secure.
  10. Close the DC Disconnect as described in Section 8.4 "Closing the DC Disconnect", page 59.
  11. Close the Sunny Boy as described in Section 8.2 "Closing the Sunny Boy", page 56.
- The AC cables are now connected.

## 5.5 DC Connection

### **⚠ DANGER**

#### **High voltages on PV modules that are exposed to light**

Risk of death due to electric shock from touching a DC conductor.

- Do not touch the DC conductor.

#### **High voltages in the DC cables**

Risk of death or serious injury from touching a DC cable.

- Only connect the DC cable from the PV module to the inverter as described in this manual.

### **⚠ CAUTION**

#### **Danger of burning due to overheating**

- Equip all string cables for DC+ and DC – connected to the DC Disconnect with a fuse.
- Observe the *National Electrical Code*® 2008, Section 690.35.

## Simplified Electrical Circuit Diagram of a PV plant

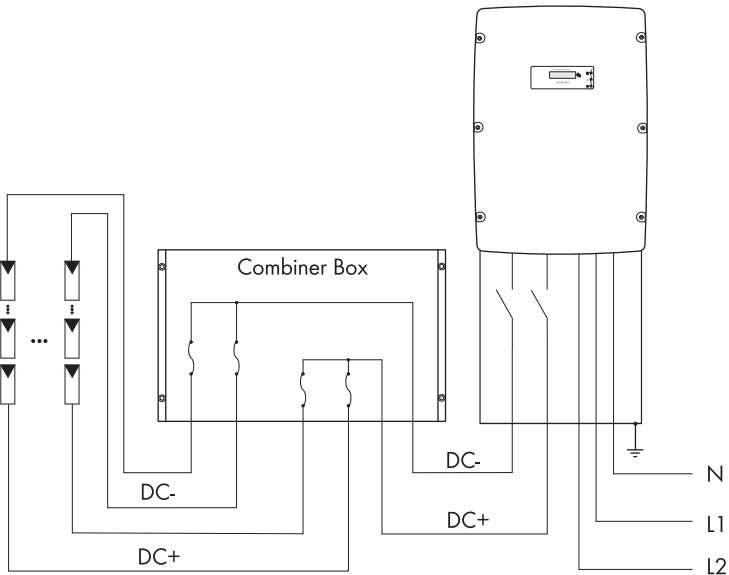

Route the PV lines precisely in the entire PV plant and do not coil.

## 5.5.1 DC Cable Requirements

### **i** Only use solid wire or stranded wire

- Use the free of charge "Sunny Design" at [www.SMA-America.com](http://www.SMA-America.com) to design your PV plant.

### DC cabling to the Combiner Box

Use copper wire that is rated for 10 to 6 AWG (6 to 16 mm<sup>2</sup>) and 194°F (90°C) (*National Electrical Code*® 690.35).

### DC cabling Between the Combiner Box and the Inverter

Use copper wire that is rated for min. 8 AWG (10 mm<sup>2</sup>) and 194°F (90°C) (*National Electrical Code*® 690.35).

## 5.5.2 Connecting the DC Cables in the DC Disconnect

1. Lay a conduit from the Sunny Boy Combiner Box to the DC Disconnect (see Section 5.2 "Inserting the Cables in the DC Disconnect", page 31).
2. Open the DC Disconnect as described in Section 8.3 "Opening the DC Disconnect", page 58.
3. Pull the DC cable from the Sunny Boy Combiner Box through the conduit into the DC Disconnect.

### **i** Open terminals fully before insertion of the cables.

4. Connect the grounding conductor to terminal (B) for the grounding conductor.

#### If necessary:

Connect the grounding cable of the PV frame to terminal (A) for the grounding conductor.

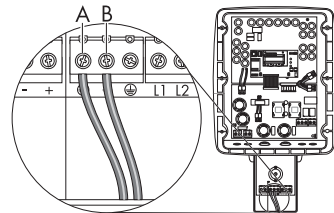



5. Check the connection cables of the PV modules for correct polarity and at the same time ensure that the maximum input voltage of the Sunny Boy is not exceeded.
6. Open the screw terminals completely by turning the screws counterclockwise with a flat-head screwdriver.
7. Connect the negative DC cables (A) to the terminal labeled - in the SMA DC Disconnect.
8. Connect the positive DC cables (A) to the terminal labeled + in the SMA DC Disconnect.

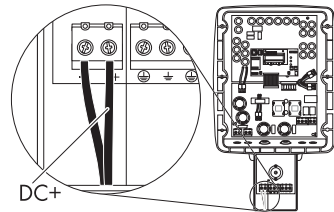
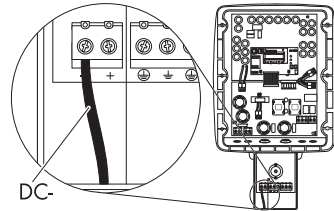

9. Tighten all cables in the terminal blocks in the SMA DC Disconnect with a torque of 40 in-lb. (4.5 Nm).
10. Verify that all connections are correctly cabled and tightened to the correct torque.
  - The DC cables are now connected to the SMA DC Disconnect.

### 5.5.3 Connecting the DC cable in the Sunny Boy

1. Open the Sunny Boy as described in Section 8.1 "Opening the Sunny Boy", page 55.
2. Push the DC cables from the SMA DC Disconnect through the grommet in the Sunny Boy in order to pierce the grommet. Do not use sharp tools to pierce the grommet.

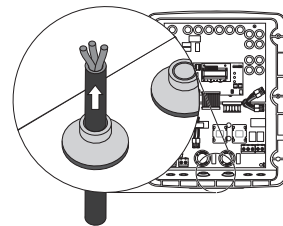

3. Pull the cables slightly back in order to seal the grommet.

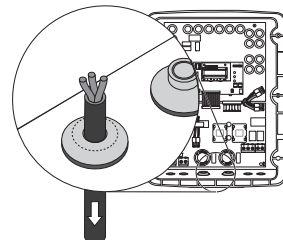

4. Open the screw terminals completely by turning them counterclockwise using a flat-head screwdriver.
5. Connect the positive DC cable to the terminal labeled DC+ in the Sunny Boy.

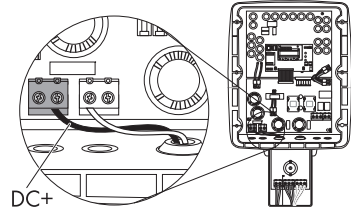

6. Connect the negative DC cable to the terminal labeled DC- in the Sunny Boy.

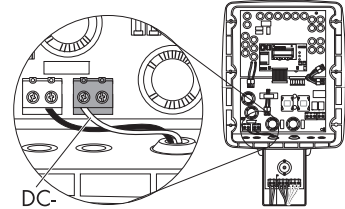

7. Tighten all cables in the terminal blocks in the Sunny Boy with a torque of 40 in-lb. (4.5 Nm).
  8. Verify that all connections are correctly cabled and tightened to the correct torque. Pull on the cable in order to make sure that it is attached tightly enough in the terminal.
  9. Close the SMA DC Disconnect as described in Section 8.4 "Closing the DC Disconnect", page 59.
  10. Close the Sunny Boy as described in Section 8.4 "Closing the DC Disconnect", page 59.
- The DC cables are now connected in the Sunny Boy.

## 5.6 Communication

The Sunny Boy can be equipped with a communication interface in order to communicate with SMA communication products.

You will find further information and a list of applicable communication products at [www.SMA-America.com](http://www.SMA-America.com).

## 6 Commissioning

### **⚠ DANGER**

#### High voltages in the PV plant during solar irradiation

Risk of death or serious injuries due to incorrect commissioning.

- Only commission the Sunny Boy in the following order.

### Requirements

- The AC cable is correctly connected.
- The DC cable is correctly connected.
- The enclosure lid is securely closed.
- The miniature circuit-breaker is correctly rated.

### 6.1 Switching On the Sunny Boy

1. Remove all covers from the PV array.
2. Switch on the AC miniature circuit-breaker.
3. Turn the DC Disconnect to position "I",

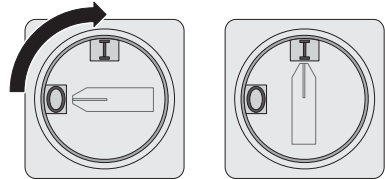

- The Sunny Boy performs an AFCI self-test.

#### **i** AFCI Self-test

Only the following types of Sunny Boy perform an AFCI self-test:

- SB 6000TLUS-12
- SB 7000TLUS-12
- SB 8000TLUS-12
- SB 9000TLUS-12
- SB 10000TLUS-12
- SB 11000TLUS-12

- If the AFCI self-test is successful: The Sunny Boy switches into the "Waiting" mode and the green LED flashes. The "Waiting" mode ends when there is sufficient solar irradiation. The green LED is permanently lit and the Sunny Boy feeds into the power distribution grid.



or

- If the AFCI self-test fails: The yellow LED flashes. The Sunny Boy repeats the AFCI self-test until it is successful. Observe Section 6.2 "The Sunny Boy Does Not Resume Operation", page 45.



If the Sunny Boy does not operate as expected, refer to the user manual.

- i** If the feed-in to the power distribution grid was interrupted by a detected AC failure and then resumed, the inverter waits 5 minutes before feeding in again.

For this, the input voltage must be greater than the start voltage of the Sunny Boy. For the corresponding values, see section 11 "Technical Data", page 70.

If the inverter is not able to feed into the power distribution grid three times in a row, it waits 10 minutes before the next attempt.

## 6.2 The Sunny Boy Does Not Resume Operation

### **⚠ DANGER**

#### **High voltages in the PV system**

Risk of death or serious injury due to electric shock.

- Only electrically skilled persons may perform work on the PV array.
- Watch the display and the LEDs.
- Refer to Section 7 "Displays and Messages", page 47 and the user manual.

#### **No operation despite sufficient solar irradiation**

1. Check whether the input voltage is sufficient. For the input voltage values, see Section 11 "Technical Data", page 70.
2. If the input voltage is not sufficient, perform troubleshooting in the PV array and rectify the fault.

or

3. If the input voltage is sufficient, contact the SMA Service Line. Observe Section 14 "Contact", page 90.

#### **The Message "Error AFCI" Is Displayed**

An electric arc occurred in the PV system. The yellow LED is permanently lit. The AFCI has tripped and the Sunny Boy is in permanent shutdown.

### **⚠ CAUTION**

#### **Danger of fire from electric arc**

- Only test the AFCI for false tripping in the order described below.
- Do not deactivate the AFCI permanently.

1. Turn the DC Disconnect to position "0".  
 Wait for the display to go out.

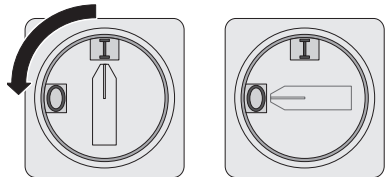

2. Perform troubleshooting in the PV system:  
Check all PV strings for the correct open-circuit voltage.

3. After the fault is rectified, restart the Sunny Boy:  
Turn the DC Disconnect to position "1".  
 The Sunny Box starts and performs another AFCI self-test.

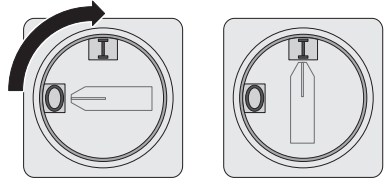

4. If the following message appears on the display, tap on the enclosure lid: "Error AFCI. Knock to restart."

**i** The message "Error AFCI. Knock to reset." appears for 10 seconds only. After this, it is no longer possible to restart the unit by tapping on the enclosure lid.

- To restart the system, repeat step 1 to step 3.

5. If the AFCI self-test is successful:  
The Sunny Boy switches into the "Waiting" mode and the green LED flashes.  
 The "Waiting" mode ends when solar irradiation reaches a certain level. The green LED lights up permanently and the Sunny Boy feeds into the power distribution grid.

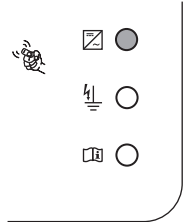

or

6. If the AFCI self-test fails:  
The Sunny Boy repeats the AFCI self-test until it is successful.
7. If the AFCI self-test continues to fail: Turn the DC Disconnect to position "0" and switch off the AC disconnect switch to the inverter.

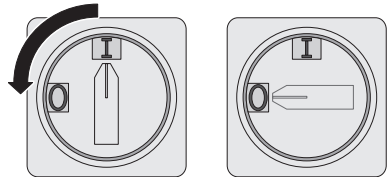

**i** If the AFCI self-test fails permanently

- Contact the SMA Service Line. Observe Section 14 "Contact", page 90.

**In the event of inverter inspection**

1. Turn the DC disconnect to position "0".  
 The Sunny Boy switches itself off.
- Disconnect the Sunny Boy on the AC side.

# 7 Displays and Messages

## The Sunny Boy LED Status Indicators

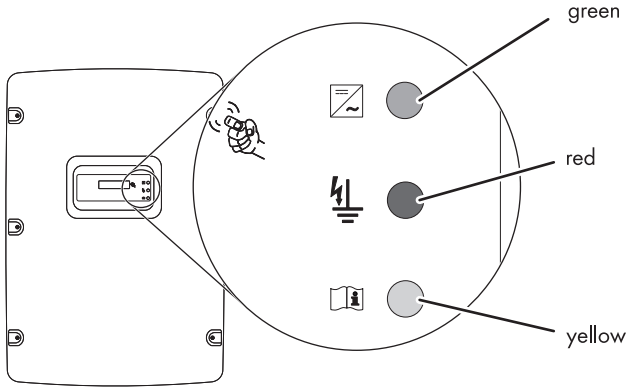

Each Sunny Boy inverter is equipped with three LED status indicators that display the operating mode of the inverter.

LED Color	Meaning
Green	Indicates standard operation of the inverter.
Red	Indicates that a ground fault is present in the PV array. The inverter does not feed into the power distribution grid. Observe Section "Ground Fault", page 53.
Yellow	Indicates that an error is present either in the inverter or in the PV plant. The inverter will not operate until the fault has been corrected. The possible error messages and causes are explained in the user manual and in Section 7 "Displays and Messages", page 47.
Red and yellow	If the yellow and red LEDs light up simultaneously, the inverter detected a ground fault. Observe Section "Ground Fault", page 53.

## 7.1 Setting the Display Language

The LCD can display information in 1 of 4 different languages. The language is configured via 2 slide switches that are located on the lower edge of the LCD.

1. Open the Sunny Boy as described in Section 8.1 "Opening the Sunny Boy", page 55.
2. Set the switches to the required language, as shown below.

Language	Switch S2	Switch S1
German	B	B
English	B	A
French	A	B
Spanish	A	A

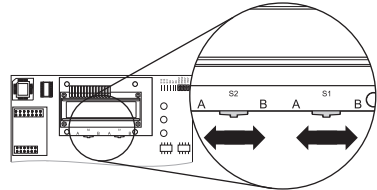

3. Close the Sunny Boy as described in Section 8.2 "Closing the Sunny Boy", page 56.
- The display language is set.

## 7.2 Display Messages

**i** Each error message is displayed for 5 seconds

- After 5 seconds, the LCD scrolls through the regular operation messages.
- The error message is repeated until the error is rectified.
- You will find an exact explanation of the display messages in the Sunny Boy user manual.

### Start phase

- Inverter type.
- Firmware version of the operation control unit and the current controlling unit.

```
Sunny Boy
WRXKuxxx
```

```
BFR Version x.xx.
SRR Version x.xx
```



## Feed-in operation

The following display messages will be given consecutively after the start phase.

- The energy generated today and the actual operating state.
- The current feed-in capacity and PV voltage.
- The total energy produced and the time that the inverter has been connected to the grid.

```
E-today 8.86kWh
Mode MPP
```

```
Pac      500W
Upv     380V
```

```
E-Total 724.4kWh
h-total  512h
```

## Disturbance

If an error occurs, the LCD switches backlight on.

- If a disturbance occurs, the message "Disturbance" will be shown in the lower line.
- The exact error message is displayed.
- If an unreliable measurement has caused the disturbance, the value measured at the time of the disturbance is displayed in the upper line.
- If another measurement of the value is possible, the latest measured value is displayed in the second line.

```
E-today  0Wh
Mode Disturbance
```

```
Disturbance
Fac-Bfr
```

```
at:      59.29Hz
Present: 59.30Hz
```

## PV overvoltage

**NOTICE****Damage to the inverter due to overvoltage**

- Disconnect the inverter from the PV array immediately.
- Error message PV overvoltage.



```
!PV-Overvoltage!  
!DISCONNECT DC!
```

1. Check the DC voltage at the DC Disconnect.
2. If the DC voltage is greater than 600 V: Contact the planner/installer of the PV array.

**or**

If the DC voltage is lower than 600 V: Connect the Sunny Boy to the PV array again as described in Section 5.5 "DC Connection", page 39.

3. If the message occurs again, disconnect the Sunny Boy from the grid and contact SMA (see Section 14 "Contact", page 90).

### 7.3 LED Display

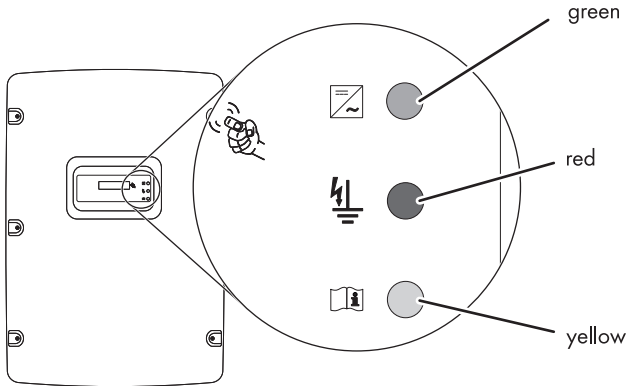

Green	Red	Yellow	Status
is permanently lit	is not lit	is not lit	OK (feed-in operation)
	is permanently lit	is not lit	Disturbance
flashes quickly (3 x per second)	is not lit	is permanently lit	OK (initialization)
	is permanently lit	is not lit	OK (stop)
flashes slowly (1 x per second)	is not lit	is not lit	Disturbance
	is permanently lit	is not lit	OK (waiting, grid monitoring)
goes out briefly (approx. 1 x per second)	is permanently lit	is not lit	Disturbance
	is not lit	is not lit	OK (derating)
is not lit	is not lit	is not lit	OK (overnight shutdown)
		is lit/flashes	Disturbance
	is permanently lit	is not lit	Disturbance
-	flashes	is lit/flashes	Disturbance
		not relevant	Warning (see Section "Ground Fault", page 53)

### Feed-in Operation

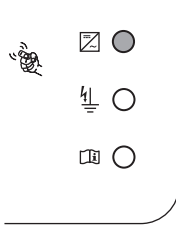

The green LED indicates error-free operation of the inverter.

### Disturbance or Fault

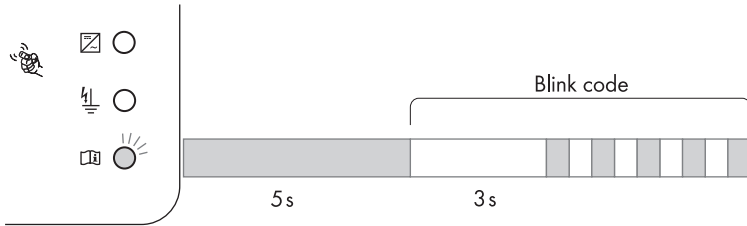

If the Sunny Boy detects a disturbance or fault, this is indicated through a blink code by the yellow LED. If the status does not change, the blink code repeats itself.

## PV Overvoltage

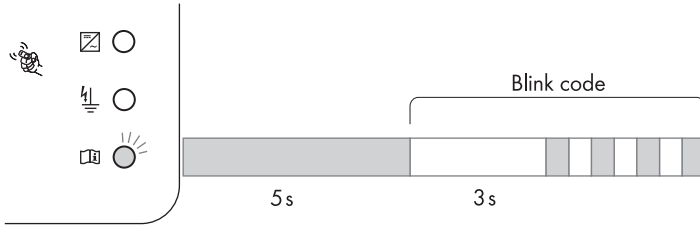

The yellow LED is on for 5 seconds, goes out for 3 seconds, then flashes 4 times. This sequence is repeated 3 times. If the status does not change, the blink code repeats itself.

The inverter has detected a DC input voltage that is too high for safe operation.

### NOTICE

#### Damage to the inverter due to overvoltage

- Disconnect the inverter from the PV array immediately.

1. Check the DC voltage at the DC Disconnect.
2. If the DC voltage is greater than 600 V: Contact the planner/installer of the PV array.

or

If the DC voltage is lower than 600 V: Connect the Sunny Boy to the PV array again as described in Section 5.5 "DC Connection", page 39.

If the message occurs again, disconnect the Sunny Boy from the grid and contact SMA (see Section 14 "Contact", page 90).

## Ground Fault

### ⚠ DANGER

#### High voltages in the PV array

Death or serious injury due to electric shock possible.

- Do not touch the PV array frame.
- Do not touch PE.
- Wait until there is no voltage before working on the PV array.
- Do not connect strings with ground faults to the inverter.
- Only electrically skilled persons may perform work on the PV array.

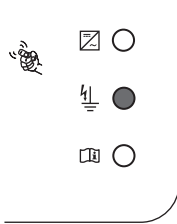

If the red LED is permanently lit, there is a ground fault in the PV array.

1. Disconnect the Sunny Boy from the DC and AC sides as described in Section 8.1 "Opening the Sunny Boy", page 55.
2. Measure the voltages between the plus and minus pole of a string against the ground potential.

3. **NOTICE**

**Damage to the measuring device through overvoltage**

- Only use a measuring device with a DC input voltage range of at least 600 V.

- ✘ If a voltage has been measured, there is a ground fault in the corresponding string.
  - The approximate position of the ground fault can be determined from the ratio of the measured voltages between the plus pole against ground potential and the minus pole against ground potential.

Example:

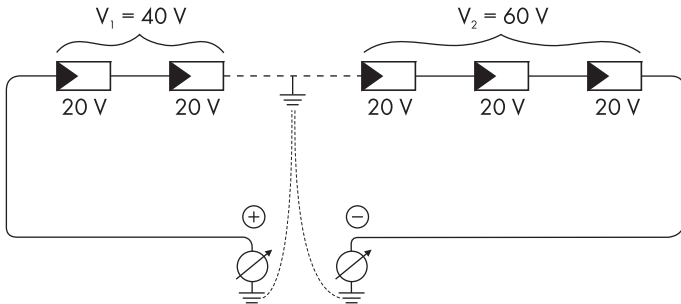

The ground fault is between the second and third module in this case.

4. Repeat step 2 on each string.
5. Resolve the ground fault in the affected string.
6. Restart the Sunny Boy as described in Section 8.2 "Closing the Sunny Boy", page 56.

## 8 Opening and Closing

### 8.1 Opening the Sunny Boy

#### **⚠ DANGER**

#### **High voltages are present in the Sunny Boy during operation**

Death or serious injury due to electric shock.

- Only open the Sunny Boy in the order described as follows.

1. Switch off all AC and DC breakers or switch-disconnectors. Ensure that the switches cannot be inadvertently reconnected.
2. Wait at least 5 minutes until the residual voltage has been drained.
3. Remove the 6 screws and conical spring washers from the enclosure lid. Pull the lid smoothly off forwards.

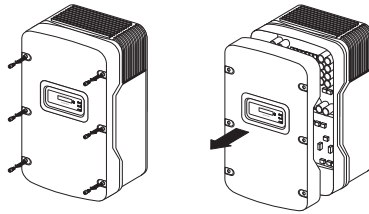

4. Put the cover, screws, and washers aside.

#### **NOTICE**

#### **Moisture can penetrate the open Sunny Boy**

Potential damage to the Sunny Boy.

- Do not open the Sunny Boy in the event of rain or a high level of humidity (>95%).
- Handle the enclosure lid with care.

#### **Damage to the seal of the enclosure lid during frost**

When opening the Sunny Boy during frost, the seal of the enclosure lid can be damaged. There may be an ingress of moisture damaging the Sunny Boy.

- Do not open the Sunny Boy when the outdoor temperature is below 23 °F ( - 5 °C).

#### **Electrostatic discharges through touching component parts**

Potential damage to the Sunny Boy.

- Ground yourself prior to touching a component part.

- The Sunny Boy is open.

## 8.2 Closing the Sunny Boy

### NOTICE

#### Damage to the enclosure lid can affect the seal between the enclosure lid and the enclosure

There may be an ingress of moisture.

Potential damage to the Sunny Boy.

- Handle the enclosure lid with care.
  - Check the seal on the inner side of the enclosure lid for damage.
  - When closing, no moisture may remain in the enclosure.
- Cables must not obstruct the seal of the enclosure lid.
  - The enclosure lid must not exert any pressure on the connections.
  - All 6 screws with conical spring washers for attaching the enclosure lid are available.
  - The seal in the inside of the lid must be undamaged and in the correct position.
1. Mount the enclosure lid onto the Sunny Boy.  
The 6 holes in the cover must be aligned with the 6 thread bores of the enclosure.

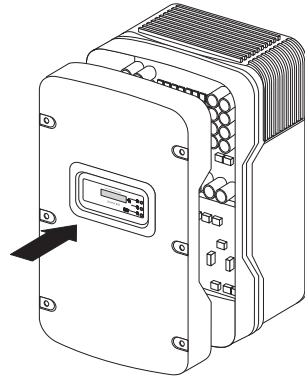



2. Hold the enclosure lid.  
Tighten the 6 screws with the conical spring washers through the holes in the enclosure lid into the threaded bores of the enclosure.

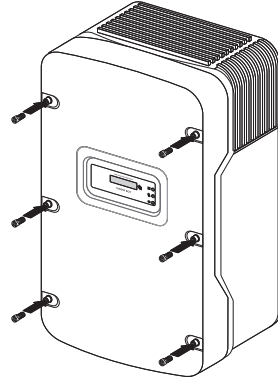

**i** Do not damage the thread of the screws

- Do not use power tools to tighten the screws.
  - The tothing of the conical spring washers must point toward the enclosure lid.
3. Check whether the enclosure lid is laying evenly on the enclosure.
  4. Tighten the 6 screws with a torque of 53 in-lb. (6 Nm).
- The Sunny Boy is closed.

### 8.3 Opening the DC Disconnect

1. Switch the DC Disconnect to "0".

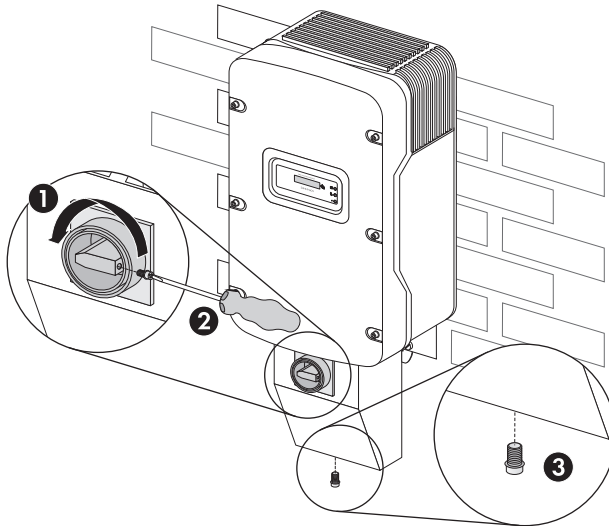

2. Loosen the screw on the rotary switch of the DC Disconnect. Use a cross-head screwdriver.

**i Do not fully remove the screws**

- If the rotary switch of the DC Disconnect cannot be removed, loosen the screw further.

3. Remove the screw and the washer of the cover on the underside of the DC Disconnect.

4. Remove the rotary switch.

5. Remove the cover of the DC Disconnect:

- Pull the cover on the underside forwards.
- At the same time, remove it from the enclosure.

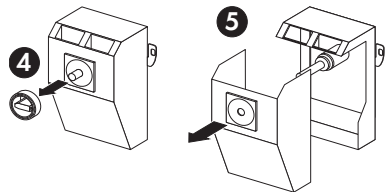

**⚠ DANGER**

**High voltages at the DC terminals with connected PV modules**

Risk of death or serious injury when touching the DC terminal.

- Do not touch any live component of the DC terminals.

- The DC Disconnect is open.

## 8.4 Closing the DC Disconnect

1. Place the cover onto the DC Disconnect and plug in the rotary handle. Turn the rotary handle to position "0".
2. Tighten the screw on the right side of the rotary handle.
3. Insert the screw and conical spring washer of the DC Disconnect into the bottom. Tighten the screw with a torque of 44 in-lb. (5 Nm).

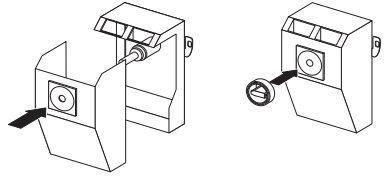

### **i** Grounding the enclosure lid

- For the grounding of the enclosure lid, the tooting of the conical spring washers must point toward the enclosure lid.

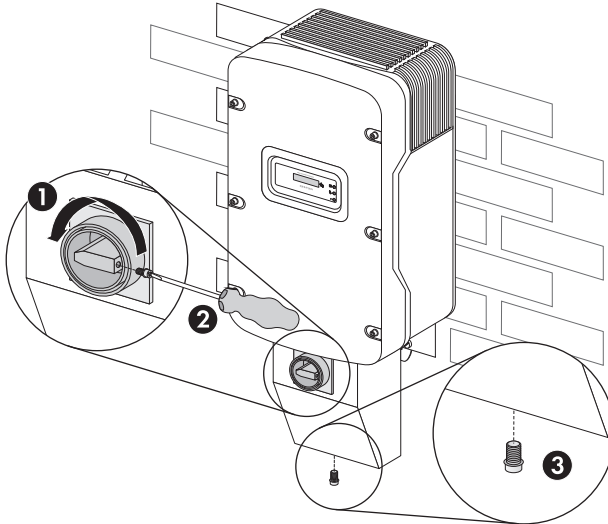

- The DC Disconnect is closed.

## 9 Maintenance

Regular maintenance ensures a long operating life and optimum efficiency of the entire PV plant.

### 9.1 Cleaning the Fans

The Sunny Boy is fitted with two fans on its underside.

The fan intakes and handle covers should be cleaned periodically with a vacuum cleaner. For more thorough cleaning, completely remove the fans.

#### NOTICE

##### Potential damage to the fans due to compressed air

- Do not use compressed air for cleaning.
- Use a soft brush or a cloth for cleaning.
- Always remove the fans for cleaning.

1. Disconnect the Sunny Boy on the AC and DC sides.
2. Wait 5 minutes until the residual voltage has been drained and the fans are no longer turning.

#### Cleaning the Fan Guards

3. Removing the fan guards:
  - Press both latches on the right edge of the fan guard to the right using a screwdriver and loosen from the retainer.
  - Carefully remove the fan guard.

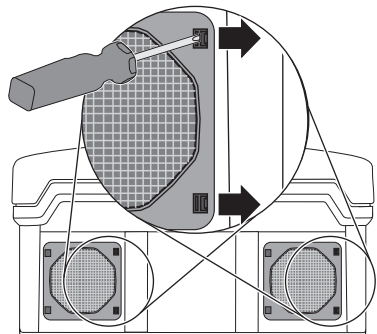

4. Clean the fan guards with a soft brush, a paint brush, a cloth or compressed air.

## Cleaning the Fans

5. Press the front latches to the rear and the rear latches to the front.

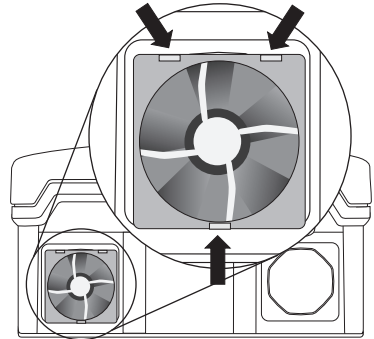

6. Remove the fan by pulling it slowly and carefully downwards.
7. Unlock and remove the plug. The cables of the fans are long enough to disconnect the plug in the inside of the Sunny Boy.
8. Remove the fan.
9. Clean the fan with a soft brush, a paint brush, or a cloth.
10. After cleaning, mount the fans and the ventilation grids in reverse order.
11. Check the function of the fans as described in Section "Checking the Fans" on page 63.

## 9.2 Cleaning the Handle Covers

For optimal heat dissipation of the device, the handle covers must be clean. Clean the handle covers regularly.

### NOTICE

#### Insects can enter the Sunny Boy

Potential damage to the Sunny Boy.

- The handle covers must not be removed permanently, otherwise the inverter is not protected against the ingress of insects.

1. Remove the handle covers. To do this, put your finger up into the space between the handle covers and the enclosure and pull the handle covers to the side.

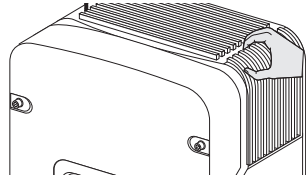

2. Clean the handle covers with a soft brush or a paint brush.
3. Re-attach the handle covers to the inverter. The side on which they are to be mounted is stated on the inside of the handle covers ("links/left" and "rechts/right").

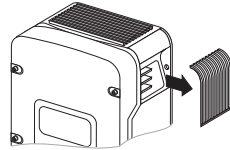

## 9.3 Checking the DC Disconnect

**i** In the case of normal use, the DC Disconnect does not require any maintenance.

Operating the switch cleans the contacts and extends the life of the DC Disconnect.

It is recommended, though not compulsory, to:

- Check the DC Disconnect regularly.
- Activate the DC Disconnect 10 times in a row once a year.

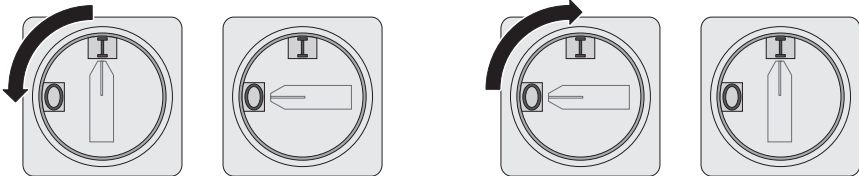

## 9.4 Checking the Fans



### In the event of frost, the fan cannot be inspected

The fans are not activated under 32°F (0°C).

You can check the operation of the fans in 2 ways:

- Set the "Fan Test" parameter to "1" in the installer mode. To do this, use a communication interface.

**or**

- Set the jumpers on the system control board. The jumpers for testing the fans are included in the scope of delivery of the Sunny Boy.

### Setting Parameters

1. Request the installer password from the SMA Service Line. See "Contact" on page 90.
2. Set the "Fan Test" parameter to "1" in the installer mode.
3. Check the air flow of the fans.
  - The Sunny Boy draws in cold air from below through the fans and blows it out again through the handle covers.
  - Pay attention to unusual sounds.
4. After checking the fans, set the parameter "Fan Test" back to "0".

## Fitting the Jumpers

**i** The Sunny Boy recognizes the jumpers after the restart.

All LEDs must be off prior to a restart.

1. Disconnect the Sunny Boy on the AC and DC sides.  
Wait 5 minutes until the residual voltage has been drained.
2. Open the Sunny Boy as described in Section 8.1 "Opening the Sunny Boy", page 55.
3. Insert the jumpers supplied into the slot on the system control board shown below.

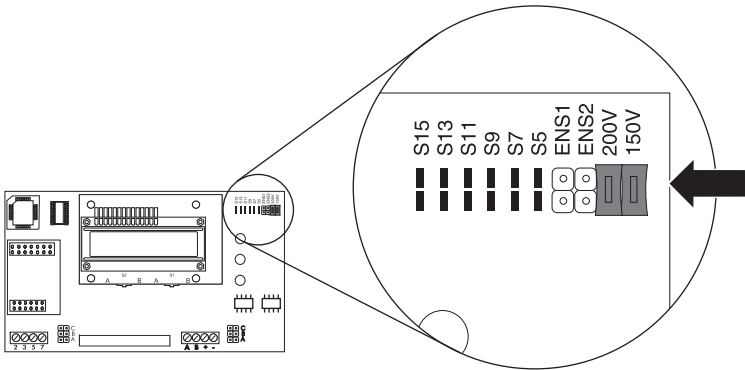

4. Close the Sunny Boy as described in Section 8.2 "Closing the Sunny Boy", page 56.
5. Check the air flow of the fans.
  - The Sunny Boy draws in cold air from below through the fans and blows it out again through the handle covers.
  - Pay attention to unusual sounds.
6. After testing the fans, remove the jumper.



## 9.5 Testing and Replacing the Varistors

In regions where storms or other DC overvoltages frequently occur, the DC varistors lose their functionality if the PV plant is not equipped with an additional overvoltage protection. To ensure that the functionality of the DC varistors remains at a constant level, SMA recommends in such cases to replace the DC varistors after an operating time of 10 years with new ones.

### NOTICE

#### No protection against overvoltage due to faulty or missing varistors

Destruction of the inverter is possible.

- Do not operate the inverter with faulty varistors or no varistors at all.
- Replace faulty varistors immediately.

### 9.5.1 DC Varistors

- i** Only the following inverter types are equipped with DC varistors:  
 SB 6000TLUS-12/SB 7000TLUS-12/SB 8000TLUS-12/SB 9000TLUS-12/  
 SB 10000TLUS-12/SB 11000TLUS-12.

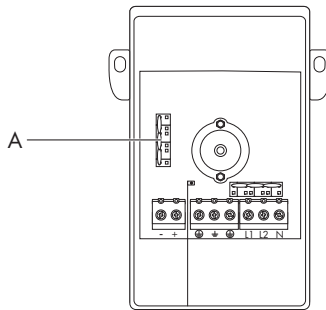

Position	Description
A	DC varistors

1. Disconnect the Sunny Boy on the AC and DC sides.
2. Wait 5 minutes for the component parts to cool down.
3. Open the DC disconnect as described in Section 8.3 "Opening the DC Disconnect", page 58.

4. Check the DC varistors for discoloration and visible damage.
- ✘ If one of the DC varistors is discolored or damaged, replace all DC varistors:

**i** Only use spare parts from SMA

- Always replace the entire set of DC varistors.
  - Order number in Section 12 "Spare Parts and Accessories", page 88.
- Insert the insertion tool into the rectangular opening of the terminal.

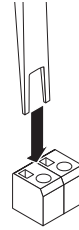

- Remove the DC varistor.

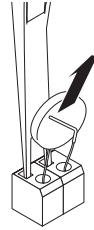

- Insert the new DC varistor into the terminal.



- Pull the insertion tool out of the rectangular opening of the terminal.

5. Ensure that all DC varistors in the terminals are securely in place.
6. Close the DC disconnect as described in Section 8.4 "Closing the DC Disconnect", page 59.
- ☑ Testing and replacement of the DC varistors is completed.

### 9.5.2 AC Varistors

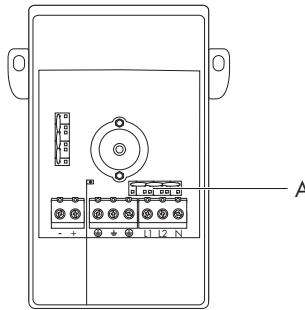

Position	Description
A	AC varistors

1. Disconnect the Sunny Boy on the AC and DC sides.
  2. Wait 5 minutes for the component parts to cool down.
  3. Open the DC disconnect as described in Section 8.3 "Opening the DC Disconnect", page 58.
  4. Ensure that no voltage is present at the AC varistors (A).
  5. Check the AC varistors (A) for discoloration and visible damage.
- ✘ If one of the AC varistors is discolored or damaged, replace all AC varistors:

**i** Only use spare parts from SMA

- Always replace the entire set of AC varistors.
  - Order number in Section 12 "Spare Parts and Accessories", page 88.
- Insert the insertion tool into the rectangular opening of the terminal (1).
  - Remove the AC varistor (2).
  - Insert the new AC varistor into the terminals (3).
- 
- Pull the insertion tool out of the openings of the terminal contacts.

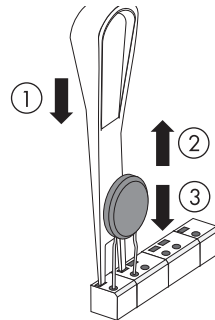

6. Ensure that all AC varistors in the terminals are securely in place.
  7. Close the DC disconnect as described in Section 8.4 "Closing the DC Disconnect", page 59.
- ☑ Testing and replacement of the AC varistors is completed.

## 10 Decommissioning

### 10.1 Dismantling the Sunny Boy and the DC Disconnect

1. Open the Sunny Boy as described in Section 8.1 "Opening the Sunny Boy", page 55.
2. Remove all cables connected to the Sunny Boy.
3. Close the Sunny Boy as described in Section 8.2 "Closing the Sunny Boy", page 56.
4. Open the DC Disconnect as described in Section 8.3 "Opening the DC Disconnect", page 58.
5. Remove all cables connected to the DC Disconnect.

6. **⚠ CAUTION**

**The Sunny Boy may fall down due to inappropriate disassembly.**

Contusions or bone fractures due to the heavy weight of the Sunny Boy.

- Prior to disassembling the Sunny Boy, take its weight of 77 lb. (35 kg) into account.
- Use suitable lifting technique when disassembling.

7. Remove both screws on the left and right side of the Sunny Boy that attach it to the wall mounting bracket.

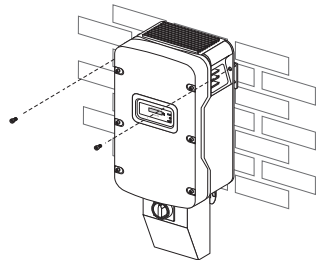

8. Remove the Sunny Boy vertically upwards from the wall mounting bracket.
9. 2 people must transport the Sunny Boy using the side handles at the top and bottom.

or

Feed a steel rod with a maximum diameter of  $1\frac{1}{8}$  in. (30 mm) through the enclosure openings at the top. 2 people must transport the Sunny Boy.

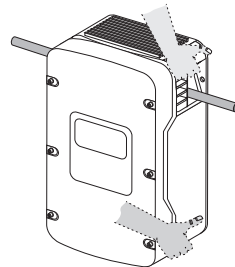

10. Remove both screws on the left and right side of the DC Disconnect that attach it to the wall mounting bracket.

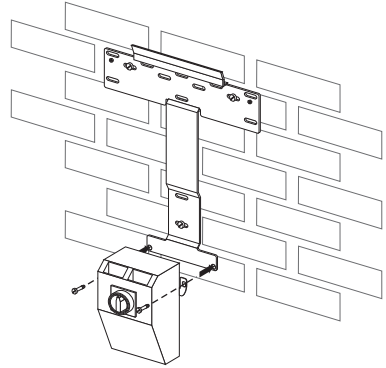

## 10.2 Packaging the Sunny Boy

- Pack the Sunny Boy and DC Disconnect. Use the original packaging or packaging that is suitable for the weight and dimensions of the inverter.

## 10.3 Storage

Store the Sunny Boy and the DC Disconnect in a dry place. The ambient temperature must be between  $-40^{\circ}\text{F}$  ( $-40^{\circ}\text{C}$ ) and  $+140^{\circ}\text{F}$  ( $+60^{\circ}\text{C}$ ).

## 10.4 Disposal

- Dispose of the Sunny Boy and the DC Disconnect in accordance with the disposal regulations for electronic waste that apply at the installation site.

or

- Send the Sunny Boy and the DC Disconnect to SMA carriage paid (see Section 14 "Contact", page 90). When doing so, label the packaging with the information "FOR DISPOSAL".

# 11 Technical Data

## 11.1 Sunny Boy 6000TL-US

### PV Array Connection

Maximum DC power	6,200 W
Maximum DC voltage	600 V
Minimum DC voltage at 208 V AC	300 V
Minimum DC voltage at 240 V AC	345 V
DC nominal voltage at 208 V AC	345 V
DC nominal voltage at 240 V AC	379 V
DC start voltage	360 V
MPP voltage range at 208 V AC	300 V to 480 V
MPP voltage range at 240 V AC	345 V to 480 V
Maximum DC input current at 208 V AC	21 A
Maximum DC input current at 240 V AC	18 A
Number of MPP trackers	1 (OptiTrac)

### Grid Connection

AC nominal power	6,000 W
Maximum AC power	6,000 W
Reduced power output at 140°F (60°C)	6,000 W
Maximum AC current at 208 V AC	33 A
Maximum AC current at 240 V AC	29 A
Maximum AC reverse current	0 A
Maximum AC fuse size	45 A
AC nominal voltage	208 V/240 V
AC voltage range at 208 V AC	183 V to 229 V
AC voltage range at 240 V AC	211 V to 264 V
AC nominal frequency	60 Hz
AC nominal frequency range	59.3 Hz to 60.5 Hz
Power factor at nominal power	1
Total harmonic factor	< 4%
AC connection/Power Balancing	Two Phases / ✓
Ground fault monitoring (R-Iso)	Yes
Power consumption nighttime	≤ 0.25 W

### Protection Devices

DC reverse polarity protection	Short-circuit diode
AC short-circuit current capability	Software-controlled
AC overcurrent protection	Current-controlled
Grid monitoring	SMA Grid Guard

### General Data

Topology	Transformerless H5
Cooling concept	OptiCool
Protection class	NEMA 3R
Optional communication interfaces	RS485/wireless ( <i>Bluetooth</i> )
DC connection	Screw terminals
AC connection	Screw terminals

### Efficiency

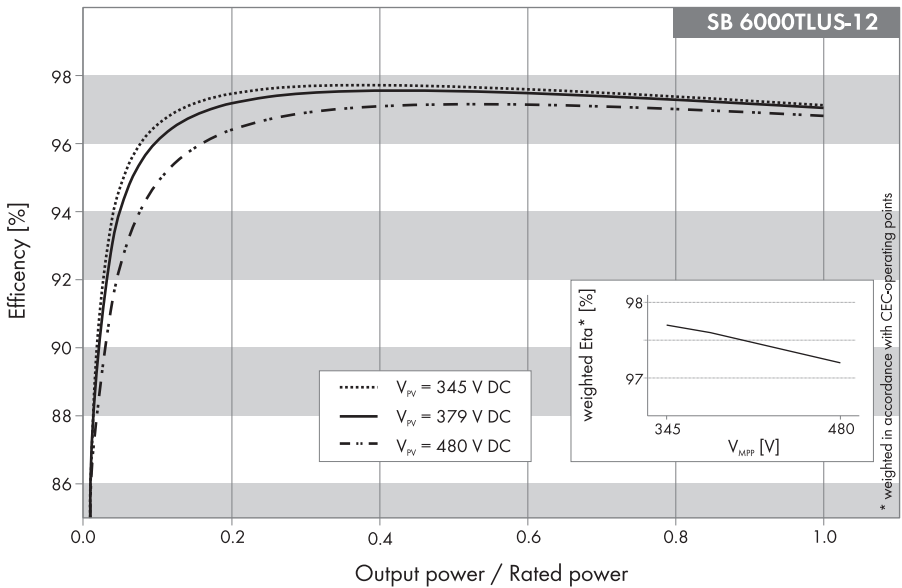

Inverter peak efficiency	98.3%
CEC weighted efficiency	98%

## Ambient Conditions

Ambient temperature range <b>SB 6000TLUS-12</b>	- 40°F to +140°F ( - 40°C to +60°C)
---	--

## Mechanical Data

Width x height x depth (including DC Disconnect)	18 <sup>3</sup> / <sub>8</sub> in. x 33 in. x 9 <sup>7</sup> / <sub>16</sub> in. 467 mm x 838 mm x 241 mm
Weight of the inverter	77 lb (35 kg)
Weight of the DC Disconnect	8 lb (3.5 kg)
Noise emission	≤ 46 dB(A)

## 11.2 Sunny Boy 7000TL-US

### PV Array Connection

Maximum DC power	7,200 W
Maximum DC voltage	600 V
Minimum DC voltage at 208 V AC	300 V
Minimum DC voltage at 240 V AC	345 V
DC nominal voltage at 208 V AC	345 V
DC nominal voltage at 240 V AC	379 V
DC start voltage	360 V
MPP voltage range at 208 V AC	300 V to 480 V
MPP voltage range at 240 V AC	345 V to 480 V
Maximum DC input current at 208 V AC	24 A
Maximum DC input current at 240 V AC	21 A
Number of MPP trackers	1 (OptiTrac)



## Grid Connection

AC nominal power	7,000 W
Maximum AC power	7,000 W
Reduced power output at 140°F (60°C)	7,000 W
Maximum AC current at 208 V AC	39 A
Maximum AC current at 240 V AC	34 A
Maximum AC reverse current	0 A
Maximum AC fuse size	45 A
AC nominal voltage	208 V/240 V
AC voltage range at 208 V AC	183 V to 229 V
AC voltage range at 240 V AC	211 V to 264 V
AC nominal frequency	60 Hz
AC nominal frequency range	59.3 Hz to 60.5 Hz
Power factor at nominal power	1
Total harmonic factor	< 4%
AC connection/Power Balancing	Two Phases / ✓
Ground fault monitoring (R-Iso)	Yes
Power consumption nighttime	≤ 0.25 W

## Protection Devices

DC reverse polarity protection	Short-circuit diode
AC short-circuit current capability	Software-controlled
AC overcurrent protection	Current-controlled
Grid monitoring	SMA Grid Guard 2

## General Data

Topology	Transformerless H5
Cooling concept	OptiCool
Protection class	NEMA 3R
Optional communication interfaces	RS485/wireless ( <i>Bluetooth</i> )
DC connection	Screw terminals
AC connection	Screw terminals

### Efficiency

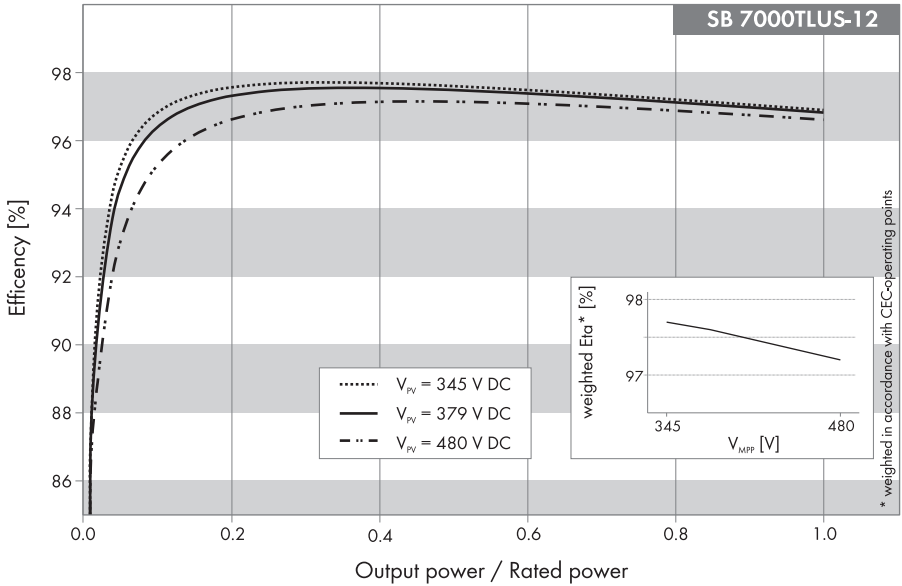

Inverter peak efficiency	98.3%
CEC weighted efficiency	98%

### Ambient Conditions

Ambient temperature range <b>SB 7000TLUS-12</b>	- 40°F to +140°F (- 40°C to +60°C)
---	---------------------------------------

### Mechanical Data

Width x height x depth (including DC Disconnect)	18 <sup>3</sup> / <sub>8</sub> in. x 33 in. x 9 <sup>7</sup> / <sub>16</sub> in. 467 mm x 838 mm x 241 mm
Weight of the inverter	77 lb (35 kg)
Weight of the DC Disconnect	8 lb (3.5 kg)
Noise emission	≤ 46 dB(A)

## 11.3 Sunny Boy 8000TL-US

### PV Array Connection

Maximum DC power	8,300 W
Maximum DC voltage	600 V
Minimum DC voltage at 208 V AC	300 V
Minimum DC voltage at 240 V AC	345 V
DC nominal voltage at 208 V AC	345 V
DC nominal voltage at 240 V AC	379 V
DC nominal voltage	345 V
DC start voltage	360 V
MPP voltage range at 208 V AC	300 V to 480 V
MPP voltage range at 240 V AC	345 V to 480 V
Maximum DC input current at 208 V AC	28 A
Maximum DC input current at 240 V AC	24 A
Number of MPP trackers	1 (OptiTrac)

### Grid Connection

AC nominal power	8,000 W
Maximum AC power	8,000 W
Reduced power output at 140 °F (60 °C)	8,000 W
Maximum AC current at 208 V AC	44 A
Maximum AC current at 240 V AC	38 A
Maximum AC reverse current	0 A
Maximum AC fuse size	60 A
AC nominal voltage	208 V/240 V
AC voltage range at 208 V AC	183 V to 229 V
AC voltage range at 240 V AC	211 V to 264 V
AC nominal frequency	60 Hz
AC nominal frequency range	59.3 Hz to 60.5 Hz
Power factor at nominal power	1
Total harmonic factor	< 4%
AC connection/Power Balancing	Two Phases / ✓
Ground fault monitoring (R-Iso)	Yes
Power consumption nighttime	≤ 0.25 W

### Protection Devices

DC reverse polarity protection	Short-circuit diode
AC short-circuit current capability	Software-controlled
AC overcurrent protection	Current-controlled
Grid monitoring	SMA Grid Guard

### General Data

Topology	Transformerless H5
Cooling concept	OptiCool
Protection class	NEMA 3R
Optional communication interfaces	RS485/wireless (Bluetooth)
DC connection	Screw terminals
AC connection	Screw terminals

### Efficiency

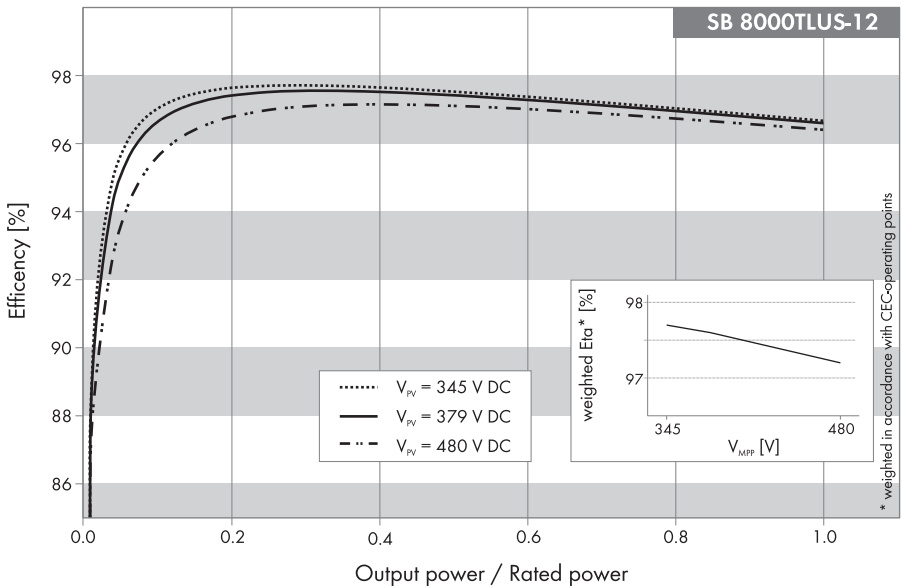

Inverter peak efficiency	98.3%
CEC weighted efficiency	98%

## Ambient Conditions

Ambient temperature range <b>SB 8000TLUS-10</b>	- 13°F to +140°F (- 25°C to +60°C)
Ambient temperature range <b>SB 8000TLUS-12</b>	- 40°F to +140°F (- 40°C to +60°C)

## Mechanical Data

Width x height x depth (including DC Disconnect)	18 <sup>3</sup> / <sub>8</sub> in. x 33 in. x 9 <sup>7</sup> / <sub>16</sub> in. 467 mm x 838 mm x 241 mm
Weight of the inverter	77 lb (35 kg)
Weight of the DC Disconnect	8 lb (3.5 kg)
Noise emission	≤ 46 dB(A)

## 11.4 Sunny Boy 9000TL-US

### PV Array Connection

Maximum DC power	9,300 W
Maximum DC voltage	600 V
Minimum DC voltage at 208 V AC	300 V
Minimum DC voltage at 240 V AC	345 V
DC nominal voltage at 208 V AC	345 V
DC nominal voltage at 240 V AC	379 V
DC start voltage	360 V
MPP voltage range at 208 V AC	300 V to 480 V
MPP voltage range at 240 V AC	345 V to 480 V
Maximum DC input current at 208 V AC	31 A
Maximum DC input current at 240 V AC	27 A
Number of MPP trackers	1 (OptiTrac)

## Grid Connection

AC nominal power	9,000 W
Maximum AC power	9,000 W
Reduced power output at 140°F (60°C)	8,000 W
Maximum AC current at 208 V AC	49 A
Maximum AC current at 240 V AC	43 A
Maximum AC reverse current	0 A
Maximum AC fuse size	60 A
AC nominal voltage	208 V/240 V
AC voltage range at 208 V AC	183 V to 229 V
AC voltage range at 240 V AC	211 V to 264 V
AC nominal frequency	60 Hz
AC nominal frequency range	59.3 Hz to 60.5 Hz
Power factor at nominal power	1
Total harmonic factor	< 4%
AC connection/Power Balancing	Two Phases / ✓
Ground fault monitoring (R-Iso)	Yes
Power consumption nighttime	≤ 0.25 W

## Protection Devices

DC reverse polarity protection	Short-circuit diode
AC short-circuit current capability	Software-controlled
AC overcurrent protection	Current-controlled
Grid monitoring	SMA Grid Guard

## General Data

Topology	Transformerless H5
Cooling concept	OptiCool
Protection class	NEMA 3R
Optional communication interfaces	RS485/wireless ( <i>Bluetooth</i> )
DC connection	Screw terminals
AC connection	Screw terminals

### Efficiency

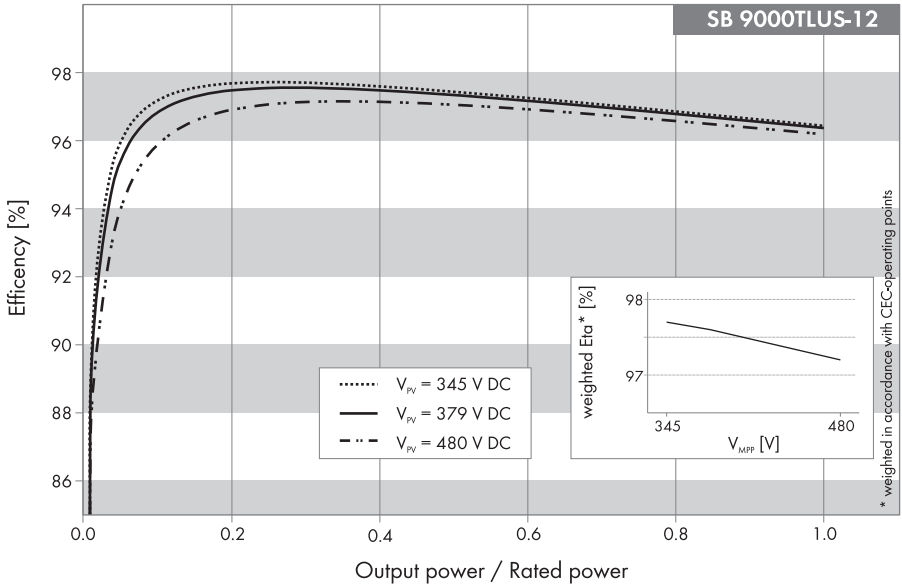

Inverter peak efficiency	98.3%
CEC weighted efficiency	98%

### Ambient Conditions

Ambient temperature range <b>SB 9000TLUS-10</b>	- 13°F to +140°F (- 25°C to +60°C)
Ambient temperature range <b>SB 9000TLUS-12</b>	- 40°F to +140°F (- 40°C to +60°C)

### Mechanical Data

Width x height x depth (including DC Disconnect)	18 <sup>3</sup> / <sub>8</sub> in. x 33 in. x 9 <sup>7</sup> / <sub>16</sub> in. 467 mm x 838 mm x 241 mm
Weight of the inverter	77 lb (35 kg)
Weight of the DC Disconnect	8 lb (3.5 kg)
Noise emission	≤ 46 dB(A)

## 11.5 Sunny Boy 10000TL-US

### PV Array Connection

Maximum DC power	10,350 W
Maximum DC voltage	600 V
Minimum DC voltage at 208 V AC	300 V
Minimum DC voltage at 240 V AC	345 V
DC nominal voltage at 208 V AC	345 V
DC nominal voltage at 240 V AC	379 V
DC start voltage	360 V
MPP voltage range at 208 V AC	300 V to 480 V
MPP voltage range at 240 V AC	345 V to 480 V
Maximum DC input current at 208 V AC	35 A
Maximum DC input current at 240 V AC	30 A
Number of MPP trackers	1 (OptiTrac)

### Grid Connection

AC nominal power	10,000 W
Maximum AC power	10,000 W
Reduced power output at 140°F (60°C)	8,000 W
Maximum AC current at 208 V AC	49 A
Maximum AC current at 240 V AC	48 A
Maximum AC reverse current	0 A
Maximum AC fuse size	60 A
AC nominal voltage	208 V/240 V
AC voltage range at 208 V AC	183 V to 229 V
AC voltage range at 240 V AC	211 V to 264 V
AC nominal frequency	60 Hz
AC nominal frequency range	59.3 Hz to 60.5 Hz
Power factor at nominal power	1
Total harmonic factor	< 4%
AC connection/Power Balancing	Two Phases / ✓
Ground fault monitoring (R-Iso)	Yes
Power consumption nighttime	≤ 0.25 W



### Protection Devices

DC reverse polarity protection	Short-circuit diode
AC short-circuit current capability	Software-controlled
AC overcurrent protection	Current-controlled
Grid monitoring	SMA Grid Guard

### General Data

Topology	Transformerless
Cooling concept	OptiCool
Protection class	NEMA 3R
Optional communication interfaces	RS485/wireless ( <i>Bluetooth</i> )
DC connection	Screw terminals
AC connection	Screw terminals

### Efficiency

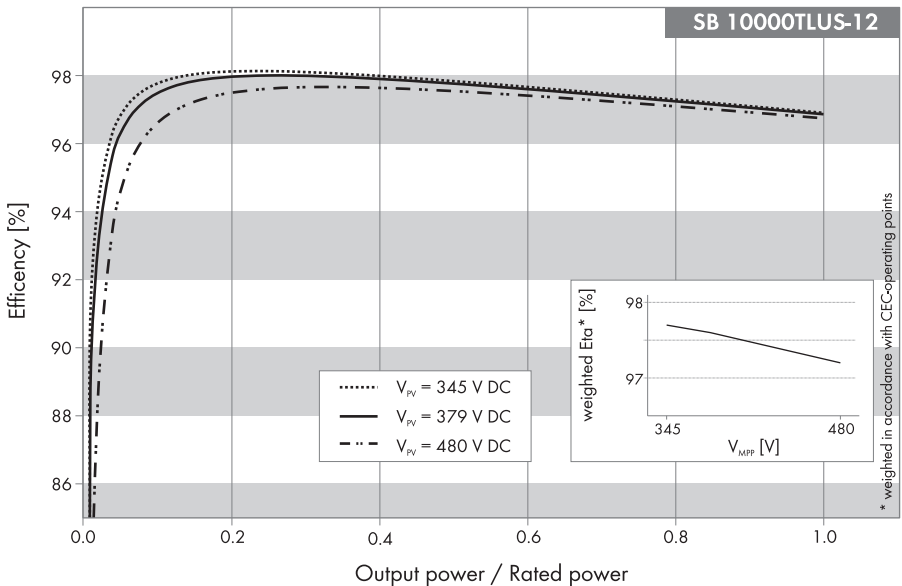

Inverter peak efficiency	98.3%
CEC weighted efficiency	97.5%

## Ambient Conditions

Ambient temperature range <b>SB 10000TLUS-10</b>	- 13°F to +140°F (- 25°C to +60°C)
Ambient temperature range <b>SB 10000TLUS-12</b>	- 40°F to +140°F (- 40°C to +60°C)

## Mechanical Data

Width x height x depth (including DC Disconnect)	18 <sup>3</sup> / <sub>8</sub> in. x 33 in. x 9 <sup>7</sup> / <sub>16</sub> in. 467 mm x 838 mm x 241 mm
Weight of the inverter	77 lb (35 kg)
Weight of the DC Disconnect	8 lb (3.5 kg)
Noise emission	≤ 46 dB(A)

## 11.6 Sunny Boy 11000TL-US

### PV Array Connection

Maximum DC power	11,400 W
Maximum DC voltage	600 V
Minimum DC voltage at 240 V AC	345 V
DC nominal voltage at 240 V AC	379 V
DC start voltage	360 V
MPP voltage range at 240 V AC	345 V to 480 V
Maximum DC input current	33 A
Number of MPP trackers	1 (OptiTrac)

## Grid Connection

AC nominal power	11,000 W
Maximum AC power	11,000 W
Reduced power output at 140 °F (60 °C)	8,000 W
Maximum AC current at 240 V AC	48.6 A
Maximum AC reverse current	0 A
Maximum AC fuse size	60 A
AC nominal voltage	240 V
AC voltage range at 240 V AC	211 V to 264 V
AC nominal frequency	60 Hz
AC nominal frequency range	59.3 Hz to 60.5 Hz
Power factor at nominal power	1
Total harmonic factor	< 4%
AC connection/Power Balancing	Two Phases / ✓
Ground fault monitoring (R-Iso)	Yes
Power consumption nighttime	≤ 0.25 W

## Protection Devices

DC reverse polarity protection	Short-circuit diode
AC short-circuit current capability	Software-controlled
AC overcurrent protection	Current-controlled
Grid monitoring	SMA Grid Guard

## General Data

Topology	Transformerless
Cooling concept	OptiCool
Protection class	NEMA 3R
Optional communication interfaces	RS485/wireless ( <i>Bluetooth</i> )
DC connection	Screw terminals
AC connection	Screw terminals

### Efficiency

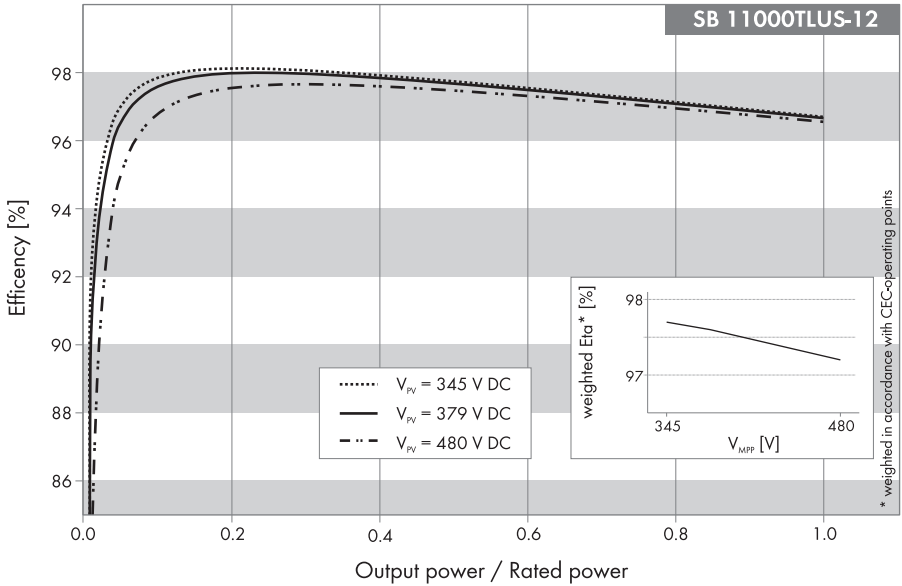

Inverter peak efficiency	98.3%
CEC weighted efficiency	97.5%

### Ambient Conditions

Ambient temperature range <b>SB 11000TLUS-12</b>	- 40°F to +140°F (- 40°C to +60°C)
--	---------------------------------------

### Mechanical Data

Width x height x depth (including DC Disconnect)	18 <sup>3</sup> / <sub>8</sub> in. x 33 in. x 9 <sup>7</sup> / <sub>16</sub> in. 467 mm x 838 mm x 241 mm
Weight of the inverter	77 lb (35 kg)
Weight of the DC Disconnect	8 lb (3.5 kg)
Noise emission	≤ 46 dB(A)

## 11.7 DC Disconnect

### PV Array Connection

Maximum DC voltage	600 V
DC operating voltage range	0 V to 600 V
Maximum DC operating current	35 A
Maximum DC short-circuit current	45 A
Maximum string fuse rating	20 A

### AC Connection

Maximum AC current	49 A
--------------------	------

### General Data

Dimensions (width x height x depth)	$7\frac{7}{8}$ in. x $11\frac{3}{4}$ in. x $7\frac{15}{32}$ in. (200 mm x 300 mm x 190 mm)
Cable Requirements ( <i>National Electrical Code</i> <sup>®</sup> , 310.16)	8 to 2 AWG (10 to 35 mm <sup>2</sup> ) copper wire, rated for 194°F (90°C)
Protection class	NEMA 3R

## 11.8 Tripping Limits and Tripping Times

Nominal frequency	Tripping limit	Tripping frequencies	Tripping times
60 Hz	> 60.5 Hz	60.45 Hz to 60.55 Hz	max. 0.1602 s
	< 57.0 Hz to 59.8 Hz (Standard 59.3 Hz)	56.95 Hz to 59.85 Hz (Standard 59.25 Hz to 59.35 Hz)	adjustable, 0.16 s to 300 s (Standard max. 0.1602 s)
	< 57.0 Hz	56.95 Hz to 57.05 Hz	max. 0.1602 s

Voltage	Tripping limit - tripping voltages	Conductor-neutral conductor	Tripping voltage - conductor-conductor	Tripping times
208 V	50%	57.6 to 62.4 V	99.8 to 108.2 V	max. 0.1602 s
	88%	103.2 to 108.0 V	178.9 to 187.2 V	max. 2.002 s
	110%	129.6 to 134.4 V	224.6 to 233.0 V	max. 1.001 s
	120%	141.6 to 146.4 V	245.4 to 253.8 V	max. 0.1602 s
240 V	50%	57.6 to 62.4 V	115.2 to 124.8 V	max. 0.1602 s
	88%	103.2 to 108.0 V	206.4 to 216.0 V	max. 2.002 s
	110%	129.6 to 134.4 V	259.2 to 268.8 V	max. 1.001 s
	120%	141.6 to 146.4 V	283.2 to 292.8 V	max. 0.1602 s

### Measurement accuracy

- Tripping limit accuracy:  $\pm 2\%$  of nominal grid voltage
- Tripping time accuracy:  $\pm 1\%$  of nominal tripping time
- Tripping frequency accuracy:  $\pm 0.05$  Hz

## 11.9 Torque Values and Cable Sizes

	in-lb.	Nm	Wire size
<b>Sunny Boy</b>			
AC terminal block	40	4.5	6 to 2 AWG (16 to 35 mm <sup>2</sup> ) copper wire, rated for 194 °F (90 °C) *
DC terminal block	40	4.5	8 to 2 AWG (10 to 35 mm <sup>2</sup> ) copper wire, rated for 194 °F (90 °C) *
Attachment to the wall mounting bracket	44	5	-
Enclosure lid	53	6	-
<b>DC Disconnect</b>			
AC terminal block	40	4.5	6 to 2 AWG (16 to 35 mm <sup>2</sup> ) copper wire, rated for 194 °F (90 °C) *
DC terminal block	40	4.5	8 to 2 AWG (10 to 35 mm <sup>2</sup> ) copper wire, rated for 194 °F (90 °C) *
Terminal block grounding conductor	40	4.5	8 to 2 AWG (10 to 35 mm <sup>2</sup> ) copper wire, rated for 194 °F (90 °C) *
Attachment to the wall mounting bracket	44	5	-
Enclosure lid	44	5	-

\*see National Electrical Code<sup>®</sup>, 310.16

## 12 Spare Parts and Accessories

If needed, you can order these from SMA or your SMA specialty retailer.

### Spare parts

Name	Description	SMA order number
Ventilation grid	Ventilation grid set, right and left	45-7202
AC varistors	AC varistor replacement kit	SB-VAC-US01
DC varistors*	DC varistor replacement kit	SB-VDC-US01

\* only SB 6000TLUS-12/SB 7000TLUS-12/SB 8000TLUS-12/SB 9000TLUS-12/SB 10000TLUS-12/SB 11000TLUS-12

### Accessories

Name	Description	SMA order number
Sunny Boy Combiner Box	String-Combiner for 6 strings maximum	SBCBT6-10
Power Balancer	Retrofit kit for the Power Balancer function	PBL-SBUS-10-NR
RS485 retrofit kit	RS485 communication interface	485USPB-SMC-NR
Bluetooth retrofit kit	Bluetooth communication interface	BTPBINV-NR



# 13 Compliance Information

## FCC Compliance

This device complies with Part 15 of the FCC Rules. Operation is subject to the following conditions:

1. This device may not cause harmful interference, and
2. This device must accept any interference received, including interference that may cause undesired operation.

NOTE: This equipment has been tested and found to comply with the limits for a Class B digital device, pursuant to Part 15 of the FCC Rules. These limits are designed to provide reasonable protection against harmful interference in a residential installation. This equipment generates, uses, and can radiate radio frequency energy and if not installed and used in accordance with the instructions, may cause harmful interference to radio communications. However, there is no guarantee that interference will not occur in a particular installation. If this equipment does cause harmful interference to radio or television reception, which can be determined by turning the equipment off and on, the user is encouraged to try to correct the interference by one or more of the following measures:

- Reorient or relocate the receiving antenna.
- Increase the separation between the equipment and the receiver.
- Connect the equipment into an outlet on a circuit different from that to which the receiver is connected.
- Consult the dealer or an experienced radio/TV technician for help.

The user is cautioned that changes or modifications not expressly approved by SMA America, LLC could void the user's authority to operate this equipment.

## IC Compliance

This device complies with Industry of Canada licence-exempt RSS standard(s). Operation is subject to the following two conditions:

- This device may not cause interference, and
- This device must accept any interference, including interferences that may cause undesired operation of the device.

## 14 Contact

If you have technical problems concerning our products, contact the SMA Service Line. We require the following information in order to provide you with the necessary assistance:

- Type of inverter
- Type and number of modules connected
- Communication method
- Sunny Boy failure or warning number
- Display message of the Sunny Boy

### **SMA Solar Technology America, LLC**

6020 West Oaks Blvd, Ste 300

Rocklin, CA 95765

Tel. +1 916 625 0870

Tel. +1 877-MY SMA TECH

Tel. +1 877 697 6283 (Toll free, available for USA, Canada and Puerto Rico)

Fax +1 916 625 0871

Service@SMA-America.com

www.SMA-America.com

### **SMA Solar Technology Canada Inc.**

2425 Matheson Blvd E , 8th Floor

Mississauga, ON L4W 5K5 , Canada

Tel. +1 877 506 1756 (Toll free, available for Canada)

Service@SMA-Canada.ca

www.SMA-Canada.ca



**SMA Solar Technology**

