

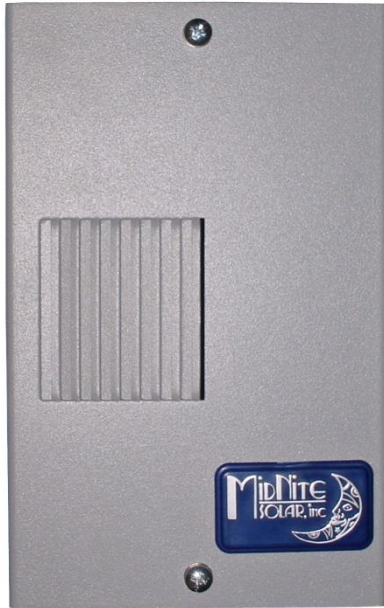

Big Baby Box / MNEDC-Quad Instructions



BIG BABY



QUAD

Features

- General use enclosure
- Convenient size for small applications
- Big Baby's DIN rail accepts up to 4 breakers (not included)
- Quad accepts up to 4 panel mount breakers (not included)
- Breakers: 1-63 amp Big Baby and 1-65 amp Quad
- Ground lug accepts up to 1/0 wire

IMPORTANT SAFETY INSTRUCTIONS

SAVE THESE INSTRUCTIONS - These instructions contain important safety and operating instructions for the MidNite Solar Big Baby and Quad breaker boxes for residential and commercial applications.

If you do not fully understand any of the concepts, terminology, or hazards outlined in these instructions, please refer installation to a qualified dealer, electrician or installer. These instructions are not meant to be a complete explanation of a renewable energy system.

GENERAL PRECAUTIONS

WORKING WITH OR IN THE VICINITY OF A LEAD ACID BATTERY, SEALED OR VENTED IS DANGEROUS. VENTED BATTERIES GENERATE EXPLOSIVE GASES DURING NORMAL OPERATION. FOR THIS REASON, IT IS VERY IMPORTANT THAT BEFORE SERVICING EQUIPMENT IN THE VICINITY OF LEAD-ACID BATTERIES, YOU REVIEW AND FOLLOW THESE INSTRUCTIONS CAREFULLY.

If service or repair should become necessary, contact MidNite solar Inc. Improper servicing may result in a risk of shock, fire or explosion. To reduce these risks, disconnect all wiring before attempting any maintenance or cleaning. Turning off the inverter will not reduce these risks. Solar modules produce power when exposed to light. When it is not possible to disconnect the power coming from the Photovoltaics by an external means such as a combiner, cover the modules with an opaque material before servicing any connected equipment.

Never attempt to charge a frozen battery.

When it is necessary to remove a battery, make sure that the battery bank disconnect breaker is in the off position and that the PV breakers, grid breakers and any other sources of power to the inverter are in the off position. Then remove the negative terminal from the battery first.

To reduce risk of battery explosion follow these instructions and those published by the battery manufacturer as well as the manufacturer of any additional equipment used in the vicinity of the batteries. Before installing the battery enclosure, read all instructions and cautionary markings in or on any connected electrical equipment.

Avoid producing sparks in the vicinity of the batteries when using vented batteries. Provide ventilation to clear the area of explosive gases. Sealed AGM and Gel batteries do not under normal conditions create explosive gases. Be especially cautious when using metal tools. Dropping a metal tool onto batteries can short circuit them. The resulting spark can lead to personal injury or damage to the equipment. Provide ventilation to outdoors from the battery compartment when installing vented batteries such as golf cart T-105 batteries. The addition of a spill tray is also a good idea.

Clean all battery terminals. Very high currents are drawn from the batteries; even a small amount of electrical resistance can result in overheating, poor performance, premature failure or even fire.

Have plenty of fresh water and soap nearby in case battery acid contacts skin, clothing or eyes. Wear complete eye and clothing protection. Always avoid touching eyes while working near batteries. If battery acid or battery terminal corrosion contacts skin or clothing, wash immediately with soap and water. If acid enters the eyes, immediately flood with cool running water for at least 15 minutes and get medical attention immediately. Baking soda neutralizes battery acid electrolyte. Keep a supply near the batteries.

Do not work alone. Someone should be in the range of your voice or close enough to come to your aid when you work with or near electrical equipment.

Remove rings, bracelets, necklaces, watches etc. when working with batteries, photovoltaic modules or other electrical equipment. Power from an illuminated photovoltaic array makes a very effective arc welder with dire consequences if one of the welded pieces is on your person.

To reduce the risk of injury, connect only deep cycle lead acid type rechargeable batteries. Other types of batteries may leak or burst, causing personal injury or damage.

E-Panel Instructions (continued)

Big Baby

The Baby Box was hugely successful in filling an industry need, but was just a little small so the Big Baby was developed to meet the need for a medium sized breaker box.

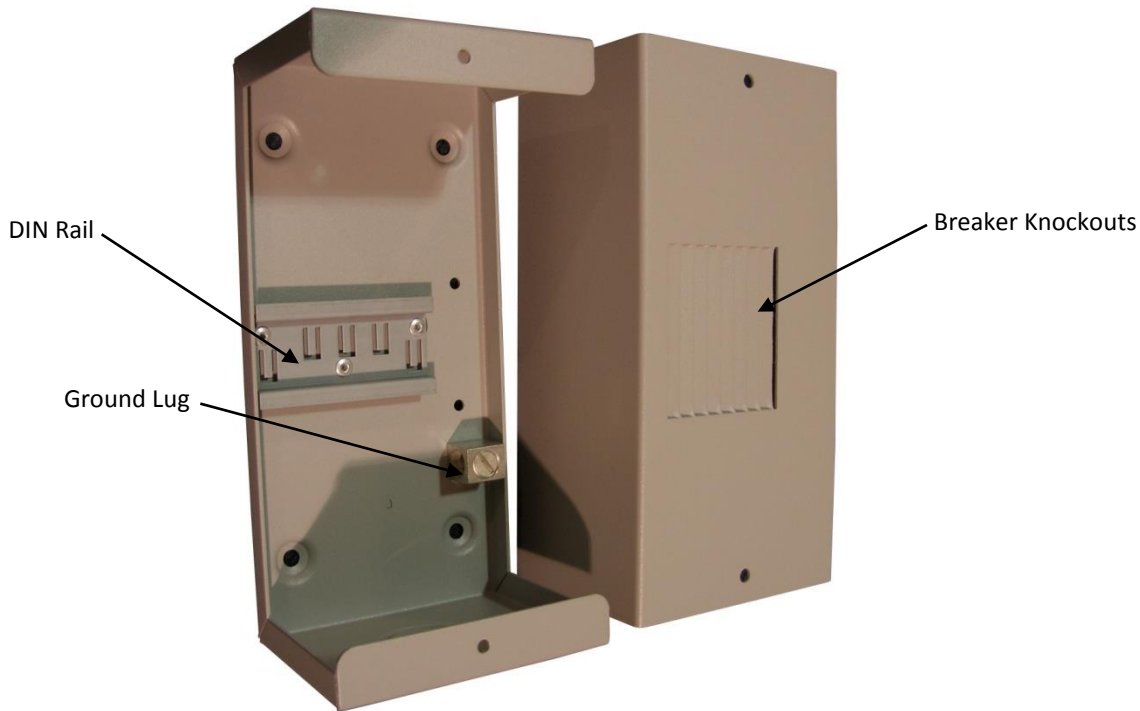

Big Baby Enclosure

Installation:

Select a safe dry indoor or sheltered location and secure to the wall with appropriate screws or wall anchors. The Big baby is a general purpose enclosure and may be used with up to four 13mm wide dinrail AC or DC breakers. Midnite Solar breakers available at your local dealer are highly recommended such as MNEPVXX where XX is the breaker rating. For example MNEPV10 is a 10 amp breaker. Other Midnite breakers and GFP's (Ground Fault Protectors) are available from your dealer. Use breakers rated for a max of 300 VDC or 277 VAC.

Wiring:

It is the installer's responsibility to ensure compliance the National Electrical Code, ANSI/NFPA 70 and all applicable local codes. A box lug is provided for grounding of the enclosure. The Big Baby is designed for up to 6AWG wire. Use of larger wire will reduce the required bending room allowance. Knockouts are provided at the top and bottom of the Big Baby. You will need a hammer, screwdriver and needle nose pliers to remove knockouts.

Torque – Ground Box Lug	
10AWG	20 in-lbs (2.3Nm)
8AWG	25 in-lbs (2.8Nm)
6AWG	35 in-lbs (4.0Nm)
4AWG	45 in-lbs (5.1Nm)
2AWG – 1/0	50 in-lbs (5.6Nm)

Torque Circuit Breaker to 20 in-lbs (2.3Nm)
Re-torque after 1 hour

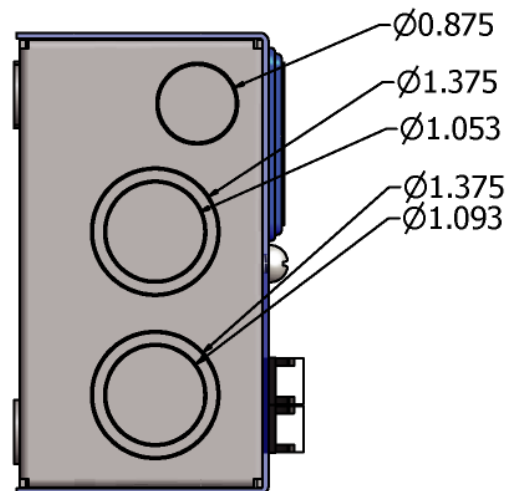

E-Panel Instructions (continued)

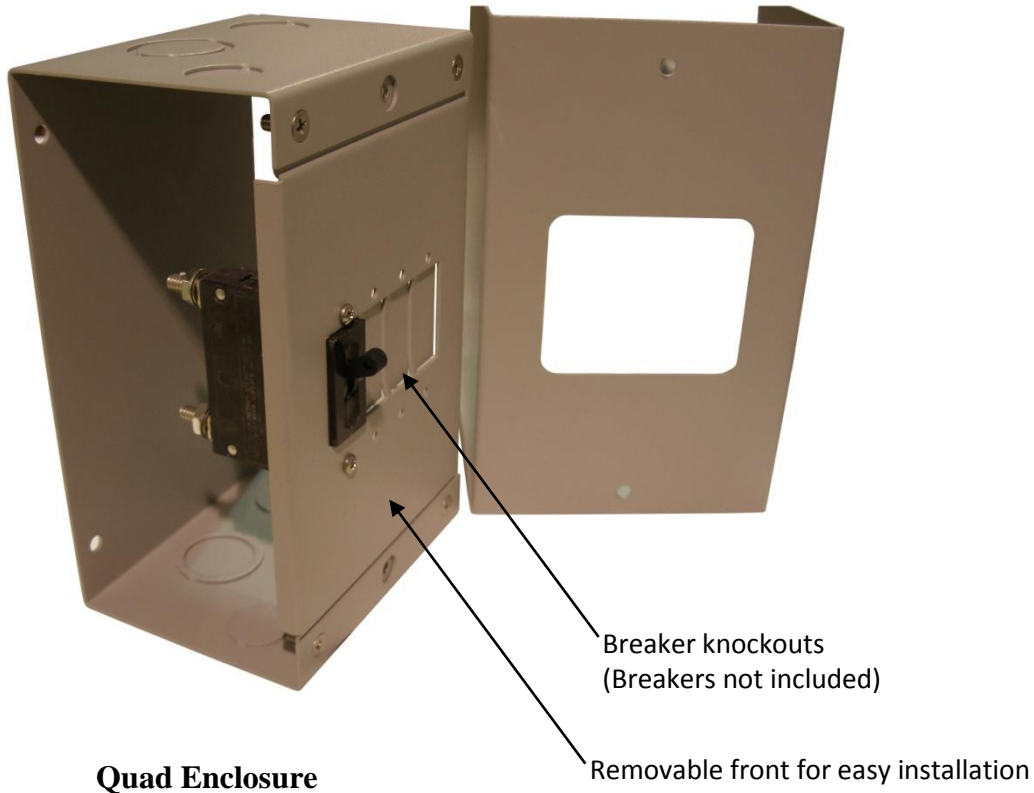

Installation:

Select a safe dry indoor or sheltered location and secure to the wall with appropriate screws or wall anchors.

Wiring:

The MNEDC Quad is a general purpose enclosure that may be used with up to 4 panel mount AC or DC breakers. Midnite Solar breakers available at your local dealer are highly recommended such as Midnite Solar part number MNEDCXX Circuit Breakers, where XX is the breaker value, for example: MNEDC10 = 10 amps. Use Breakers rated for 300 VDC or 277 VAC max.

The MNEDC Quad is designed for breakers up to 65 amps and wire up to 6 AWG. If you decide to use larger breakers and wire this will affect the required bending room for wiring. The wiring area gets pretty tight with all four breakers installed and 4 AWG wire. A box lug is provided for grounding of the enclosure. Knockouts are provided at the top and bottom of the Quad enclosure. You will need a hammer, screwdriver and needle nose pliers to remove knockouts.

Note: It is the installer’s responsibility to ensure compliance the National Electrical Code, ANSI/NFPA 70 and all applicable local codes

Torque – Ground Box Lug	
10AWG	20 in-lbs (2.3Nm)
8AWG	25 in-lbs (2.8Nm)
6AWG	35 in-lbs (4.0Nm)
4AWG	45 in-lbs (5.1Nm)
2AWG – 1/0	50 in-lbs (5.6Nm)

Torque – Circuit Breaker to 75 in-lbs (8.47Nm)
Re-torque after 1 hour

