



Small Battery Box Instructions Model MNBE-A



The MidNite MNBE-A is designed for those applications where a small battery bank is required. This enclosure is listed for indoor use. It can hold two group 31 batteries per shelf end to end or three side by side, or one 8D per shelf. Group 31 batteries are typically 105 amp hours at 12v.

IMPORTANT SAFETY INSTRUCTIONS

SAVE THESE INSTRUCTIONS - These instructions contain important safety and operating instructions for the MidNite Solar Battery Enclosure Size A for residential and commercial applications.

If you do not fully understand any of the concepts, terminology, or hazards outlined in these instructions, please refer installation to a qualified dealer, electrician or installer. These instructions are not meant to be a complete explanation of a renewable energy system.

GENERAL PRECAUTIONS

WORKING WITH OR IN THE VICINITY OF A LEAD ACID BATTERY, SEALED OR VENTED IS DANGEROUS. VENTED BATTERIES GENERATE EXPLOSIVE GASES DURING NORMAL OPERATION. FOR THIS REASON, IT IS VERY IMPORTANT THAT BEFORE SERVICING EQUIPMENT IN THE VICINITY OF LEAD-ACID BATTERIES YOU REVIEW AND FOLLOW THESE INSTRUCTIONS CAREFULLY.

If service or repair should become necessary, contact MidNite Solar Inc. Improper servicing may result in a risk of shock, fire or explosion. To reduce these risks, disconnect all wiring before attempting any

Small Battery Box Instructions

maintenance or cleaning. Turning off the inverter will not reduce these risks. Solar modules produce power when exposed to light. When it is not possible to disconnect the power coming from the Photovoltaics by an external means such as a combiner, cover the modules with an opaque material before servicing any connected equipment.

Never attempt to charge a frozen battery.

When it is necessary to remove a battery, make sure that the battery bank disconnect breaker is in the off position and that the PV breakers, grid breakers and any other sources of power to the inverter are in the off position. Then remove the negative terminal from the battery first.

To reduce risk of battery explosion follow these instructions and those published by the battery manufacturer as well as the manufacturer of any additional equipment used in the vicinity of the batteries. Before installing the battery enclosure, read all instructions and cautionary markings in or on any connected electrical equipment.

Avoid producing sparks in the vicinity of the batteries when using vented batteries. Provide ventilation to clear the area of explosive gases. Sealed AGM and Gel batteries do not under normal conditions create explosive gases. Be especially cautious when using metal tools. Dropping a metal tool onto batteries can short circuit them. The resulting spark can lead to personal injury or damage to the equipment. Provide ventilation to outdoors from the battery compartment when installing vented batteries such as golf cart T-105 batteries. The addition of a spill tray is also a good idea.

Clean all battery terminals. Very high currents are drawn from the batteries; even a small amount of electrical resistance can result in overheating, poor performance, premature failure or even fire.

Have plenty of fresh water and soap nearby in case battery acid contacts skin, clothing or eyes. Wear complete eye and clothing protection. Always avoid touching eyes while working near batteries. If battery acid or battery terminal corrosion contacts skin or clothing, wash immediately with soap and water. If acid enters the eyes, immediately flood with cool running water for at least 15 minutes and get medical attention immediately. Baking soda neutralizes battery acid electrolyte. Keep a supply near the batteries.

Do not work alone. Someone should be in the range of your voice or close enough to come to your aid when you work with or near electrical equipment.

Remove rings, bracelets, necklaces, watches etc. when working with batteries, photovoltaic modules or other electrical equipment. Power from an illuminated photovoltaic array makes a very effective arc welder with dire consequences if one of the welded pieces is on your person.

To reduce the risk of injury, connect only deep cycle lead acid type rechargeable batteries. Other types of batteries may leak or burst, causing personal injury or damage.

Small Battery Box Instructions

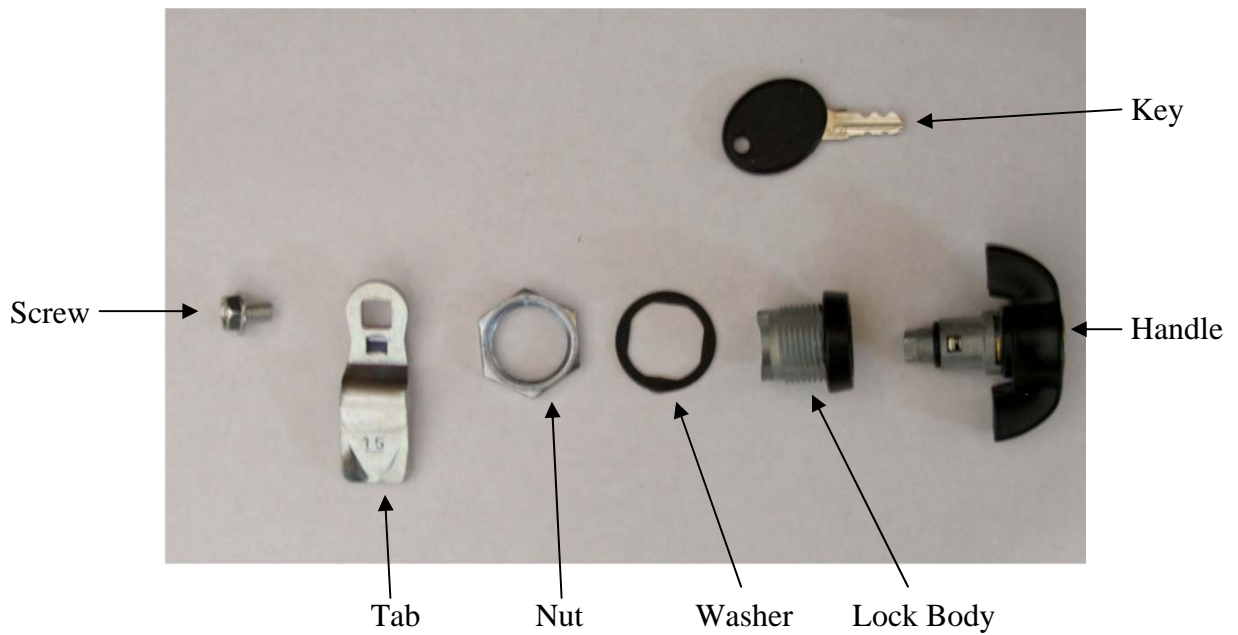
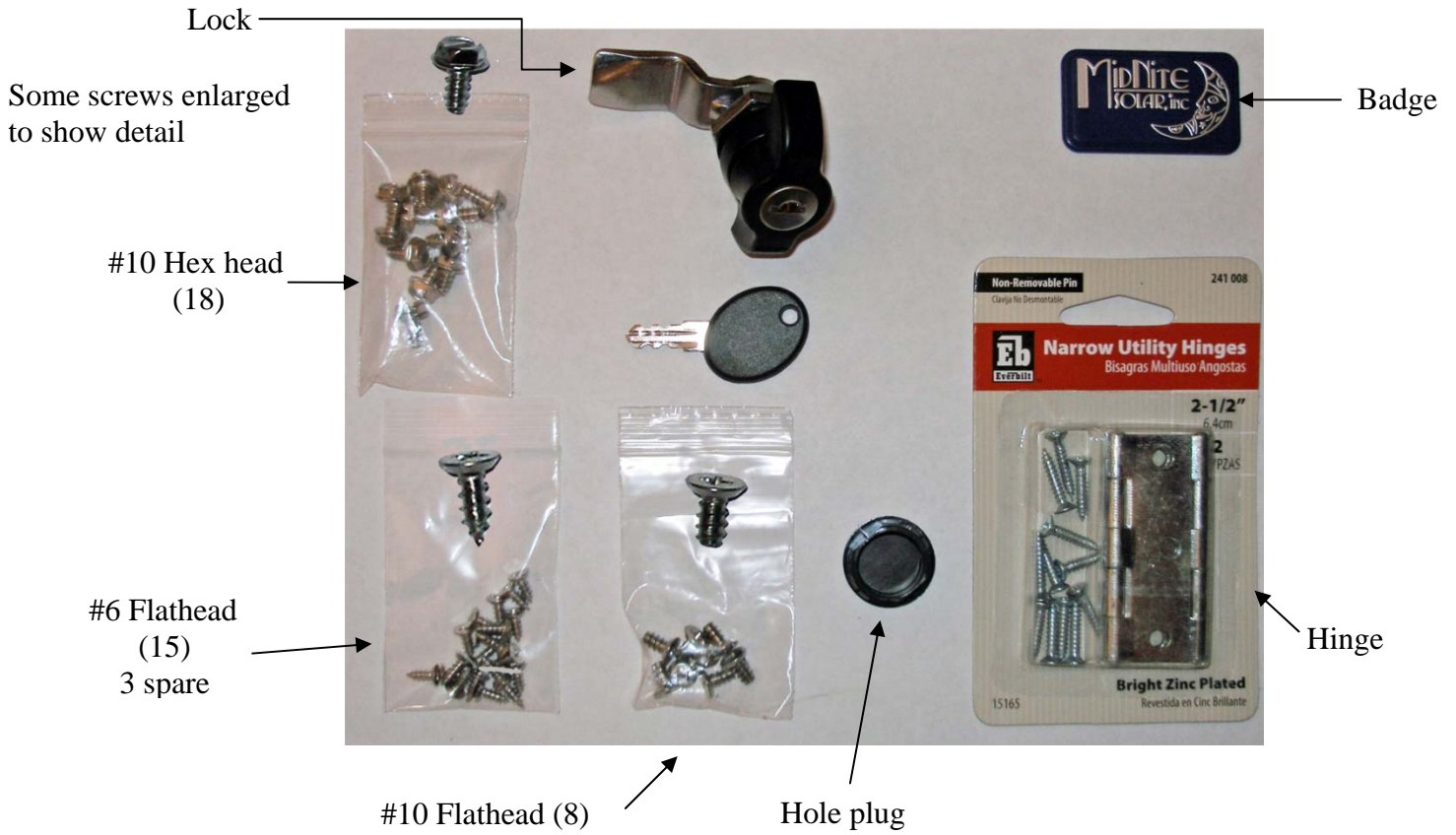

Hardware Identification

Small Battery Box Instructions

It is recommended to perform the assembly on a flat surface. You will require a #2 Philips screw driver and a 5/16" wrench to tighten screws, as well as a slotted screw driver and hammer to remove Knockouts.

Assembly:

Step 1

Attach the two shelves to the sides using eight #10 X 3/8" **Hex Head** Sheet metal screws from the sides and eight #10 **Flat head** Philips sheet metal screws front and back. See image below.

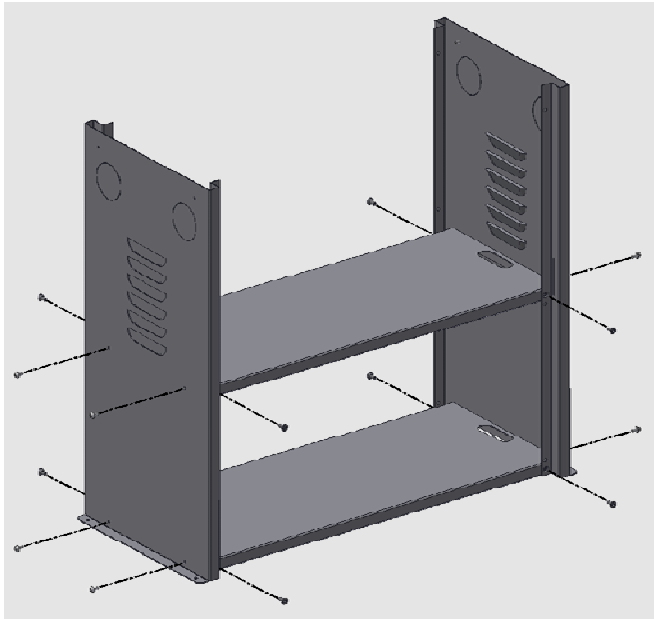

#10 **Hex head** sheet metal screw.
6 Places



Step 2

Attach back using six # 10 X 3/8 **Hex Head** sheet metal screws. Note: the front door and back panel are identical. Fill the unused lock hole with the snap in plug provided.

Step 3

Secure top to sides using four #10 X 3/8" **Hex Head** sheet metal screws. The large knockout goes towards the rear of the battery box. The MNBE-A is listed for use indoors, however if the installation is to be made outside, the inside corner seams of the top should be sealed up using 100% silicone sealant available from your local hardware store. Do this prior to installing the top cover.



Step 4

Attach hinges and door using twelve #6 X 3/8" **Flat head** Philips sheet metal screws.

Hint: attach the hinges to enclosure and then attach the door afterwards.

If mounting the enclosure outdoors, the addition of a thin weather strip around the door flanges may be required.

Small Battery Box Instructions



Lock viewed from inside



Lock viewed from outside

Step 5

Install lock. The lock will require disassembly in order to feed it through the hole and slot. The handle, lock body and washer go in from the front. Position the lock body such that the cutout faces towards the upper left as viewed from the front. Secure lock body with the nut provided from the back. Position the tab on the back of the lock and tighten screw.

Note: Unit is locked when the tab is up (behind shelf).

Optional DC Disconnect installation.

Many Jurisdictions are beginning to require DC disconnects as part of the installation. A double knockout is provided on the side of the battery box to satisfy this requirement.

Important! You must use sealed AGM or Gel batteries when installing a circuit breaker / DC disconnect in the cabinet. Circuit breakers make sparks and vented batteries cannot be in the same cabinet with any device that makes arcs and sparks. The circuit breaker must be installed in the positive leg. Do not install in the negative leg.



Battery box with no breaker.



Battery box with 125 amp DC breaker. Remove only the inner knockout



Battery box with 250 amp DC breaker and optional protector. Remove entire knockout.

You may want to bolt the enclosure down using the .265" diameter holes on the bottom side flanges. You can additionally drill holes through the back panel and bolt to a wall behind the enclosure to help make it earthquake proof.

If two enclosures are required, they can easily be stacked horizontally. There are two sets of 2" knockouts on each end plate that will accommodate running cables through a 6" long 2" diameter nipple. If stacking vertical, place a 3/4" thick piece of wood inside the top cover of the lower enclosure on each end for added strength. This will keep the lower cabinet from being crushed from the added weight. The upper enclosure should be bolted through the back to a wall.

Slots are provided at the ends of the shelves for strapping batteries to the shelves. You will need to run strapping for the bottom shelf prior to final positioning of the enclosure. Strapping is not supplied as part of the MNBE-A kit.

The enclosure is set up to use sealed batteries as is. If installing flooded batteries, you may need to add venting and spill trays. These items are not supplied by MidNite Solar.

Always use caution when hooking up batteries. They can be very dangerous. Do not wear rings or watches. Pay close attention to the order of cable installation. For instance if four 12V batteries are to be configured as a 24 volt bank, the batteries will be more safe to work around if the series connecting jumpers are installed after all other connections have been made.

Note: Battery banks below 50 volts are not required to be grounded per the NEC.

Small Battery Box Instructions

Common battery wiring configurations.

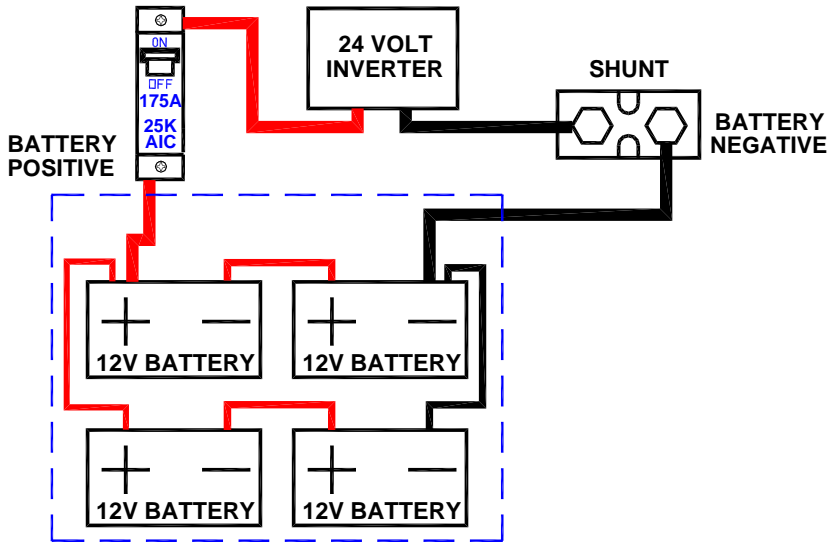

24 Volt system with four 12 volt batteries. This is a series parallel setup with two batteries in series paralleled with two more batteries in series.

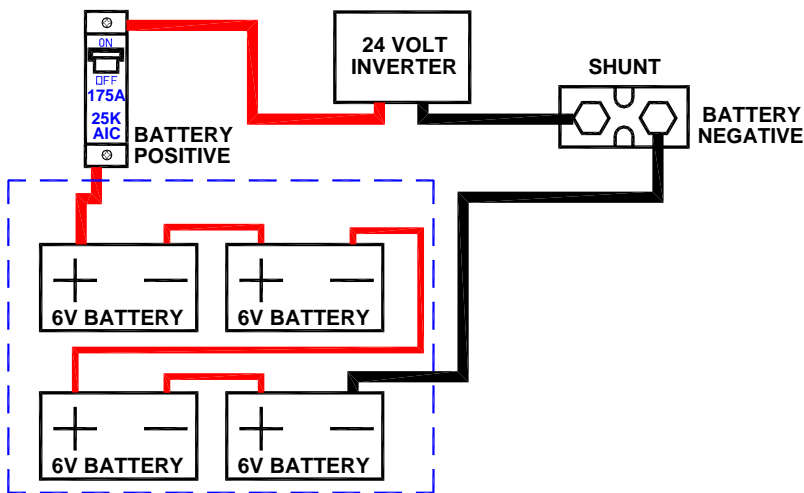

24 Volt system with 4 – 6 volt batteries. This setup has four 6 volt batteries in series to provide 24 volts.

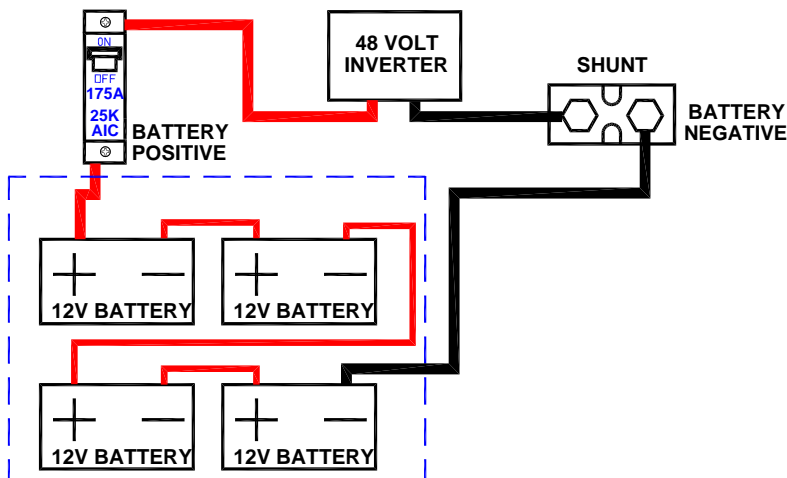

48 Volt system with 4 – 12 volt batteries. This setup has four 12 volt batteries in series to provide 48 volts.