



MPX Series Extension Kit



Owner's Manual

Disclaimer of Liability

The use of this manual and the conditions or methods of installation, operation, use, and maintenance of the MPX Extension Kit is beyond the control of Magnum Energy, Inc. Therefore, this company does not assume responsibility and expressly disclaims liability for loss, damage or expense, whether direct, indirect, consequential or incidental, arising out of or in anyway connected with such installation, operation, use, or maintenance.

Due to continuous improvements and product updates, the images shown in this manual may not exactly match the unit purchased.

Restrictions on Use

The MPX Extension Kit may only be used in life-support devices or systems with the express written approval of Magnum Energy. Failure of the MPX can reasonably be expected to cause failure of that life-support device or system, or to affect the safety or effectiveness of that device or system. If the MPX fails, it is reasonable to assume the health of the user or other persons may be endangered.

Copyright Notice

Copyright © 2011 by Magnum Energy, Inc. All rights reserved. Permission to copy, distribute, and/or modify this document is prohibited unless express written permission from Magnum Energy, Inc. is provided.

Contact Information

Magnum Energy, Inc.
2211 West Casino Rd.
Everett, WA 98204
Phone: 425-353-8833
Fax: 425-353-8390
Web: www.magnumenergy.com

Statement of Appreciation

From all of us at Magnum Energy -

Thank you for purchasing this Magnum Extension Kit (MPX).

We understand that you have many purchasing options in the marketplace, and are pleased that you have decided on a Magnum Energy product. This MPX was proudly assembled and tested in the United States at our Everett, Washington facility.

At Magnum, we are committed to providing you with quality products and services; and hope that your experience with us is pleasant and professional.

Magnum Energy® is a registered trademark of Magnum Energy, Inc.

Table of Contents

| | |
|---|-----------|
| 1.0 Safety Information | 1 |
| 1.1 Safety Symbols | 1 |
| 1.2 General Safety | 1 |
| 1.3 Battery Safety..... | 2 |
| 2.0 Introduction | 3 |
| 2.1 MPX Series Kit..... | 3 |
| 2.2 Available MPX Models..... | 5 |
| 3.0 Installation..... | 7 |
| 3.1 Installing the MPX..... | 7 |
| 3.1.1 Preparation | 7 |
| 3.1.2 Attaching the MPX to the MP Enclosure..... | 10 |
| 3.1.3 Mounting the MP Enclosure (and Attached MPX) to a Backplate/Wall..... | 10 |
| 3.1.4 Attaching the DC and AC Breakers | 11 |
| 3.1.5 Connect and Separate Inverter AC Wires | 13 |
| 3.1.6 Mounting the Second Inverter onto the MPX..... | 13 |
| 3.1.7 Attaching the Inverter Hood..... | 14 |
| 3.1.8 Attaching the Router Bracket | 16 |
| 3.1.9 Attaching the Router to the Bracket | 16 |
| 3.2 Wiring the MPX | 17 |
| 3.2.1 Wiring Guidelines | 17 |
| 3.2.2 Wiring the MPXS-30D | 20 |
| 3.2.3 Wiring the MPXS-60S..... | 33 |
| 3.2.4 Wiring the MPXD-30D | 43 |
| 3.3 Installation Checklist..... | 52 |
| 3.4 Functional Test..... | 52 |
| 3.5 Attaching Labels and Covers | 52 |
| 4.0 Warranty and Service | 58 |
| 4.1 Limited Warranty..... | 58 |
| 4.2 How to Receive Repair Service..... | 58 |

List of Tables

| | |
|---|----|
| Table 2-1, MPX AC Wire Kit Part Numbers | 4 |
| Table 2-2, DC 2/0 Battery Cable Lengths | 5 |
| Table 2-3, MPX Models | 5 |
| Table 3-1, MPX Wiring Table | 17 |

List of Figures

| | |
|---|---|
| Figure 2-1, MPX Series Kit | 3 |
| Figure 2-2, MPX Kit Labels and Hardware..... | 4 |
| Figure 2-3, MPXS-60S Installation Configurations..... | 5 |
| Figure 2-4, MPXS-30D Installation Configurations | 6 |
| Figure 2-5, MPXD-30D Model Installation Configuration | 6 |
| Figure 3-1, MPX Series Dimensions and Knockout Locations/Sizes..... | 8 |
| Figure 3-2, Removing a Knockout | 9 |

List of Figures (cont.)

| | |
|---|----|
| Figure 3-3, Removing MPX Knockouts..... | 9 |
| Figure 3-4, MPX with RTR Bracket..... | 9 |
| Figure 3-5, Attaching the MPX to an MP Enclosure..... | 10 |
| Figure 3-6, Mounting the MPX to a Backplate/Wall..... | 10 |
| Figure 3-7, Removing Breaker Screws | 11 |
| Figure 3-8, Attaching the New DC Breaker | 11 |
| Figure 3-9, Attaching the New AC Breaker Within a MP Single Enclosure | 12 |
| Figure 3-10, Attaching the New AC Breaker Within a MP Dual Enclosure..... | 12 |
| Figure 3-11, Mounting the Second Inverter on the MPX..... | 13 |
| Figure 3-12, Mounting Multiple Inverters on the MPX..... | 14 |
| Figure 3-13, Attaching the Inverter Hood..... | 15 |
| Figure 3-14, Attaching Multiple Inverter Hoods | 15 |
| Figure 3-15, Attaching the Router Bracket..... | 16 |
| Figure 3-16, Mounting the Router to the Bracket..... | 16 |
| Figure 3-17, DC Cable Connections | 19 |
| Figure 3-18a, MPXS-30D / MPSL-30D Inverter AC Wiring | 23 |
| Figure 3-18b, MPXS-30D / MPSL-30D External AC Wiring | 24 |
| Figure 3-18c, MPXS-30D / MPSL-30D Inverter DC Wiring | 25 |
| Figure 3-18d, MPXS-30D / MPSL-30D Battery Bank DC Wiring | 26 |
| Figure 3-18e, MPXS-30D / MPSL-30D Communication Wiring..... | 27 |
| Figure 3-19a, MPXS-30D / MPSH-30D Inverter AC Wiring..... | 28 |
| Figure 3-19b, MPXS-30D / MPSH-30D External AC Wiring | 29 |
| Figure 3-19c, MPXS-30D / MPSH-30D Inverter DC Wiring..... | 30 |
| Figure 3-19d, MPXS-30D / MPSH-30D Battery Bank DC Wiring | 31 |
| Figure 3-19e, MPXS-30D / MPSH-30D Communication Wiring | 32 |
| Figure 3-20a, Inverter AC Input and Output Wiring Diagram | 34 |
| Figure 3-20b, MPXS-60S / MPSL-60S AC Breaker Input Wire Transition | 35 |
| Figure 3-21a, MPXS-60S / MPSL-60S Inverter AC Wiring..... | 38 |
| Figure 3-21b, MPXS-60S / MPSL-60S External AC Wiring..... | 39 |
| Figure 3-21c, MPXS-60S / MPSL-60S Inverter DC Wiring..... | 40 |
| Figure 3-21d, MPXS-60S / MPSL-60S Battery Bank DC Wiring..... | 41 |
| Figure 3-21e, MPXS-60S / MPSL-60S Communication Wiring | 42 |
| Figure 3-22a.1, MPXD-30D / MPDH-30D Inverter AC Wiring | 46 |
| Figure 3-22a.2, MPXD-30D / MPDH-30D Inverter AC Wiring (Closeup) | 47 |
| Figure 3-22b, MPXD-30D / MPDH-30D External AC Wiring..... | 48 |
| Figure 3-22c, MPXD-30D / MPDH-30D Inverter DC Wiring | 49 |
| Figure 3-22d, MPXD-30D / MPDH-30D Battery Bank DC Wiring..... | 50 |
| Figure 3-22e, MPXD-30D / MPDH-30D Communication Wiring..... | 51 |
| Figure 3-23, Attaching the Interior DC Labels..... | 52 |
| Figure 3-24, Attaching the MP Enclosure Cover | 53 |
| Figure 3-25, Attaching the MPX Cover | 54 |
| Figure 3-26, Attaching the Router Cover | 55 |
| Figure 3-27, Attaching the Exterior Labels MPSL/MPSH | 56 |
| Figure 3-28, Attaching the Exterior Labels MPDH | 57 |

1.0 Safety Information

IMPORTANT SAFETY INSTRUCTIONS

This manual contains important safety instructions that must be followed during the installation and operation of this product. Before using the MPX, read all instructions and cautionary markings in this manual for: the MPX extension, the inverter/charger, the MP enclosure, and the batteries – as well as the individual manuals provided for each component of the system.

These installation instructions are for use by qualified personnel only. Do not perform any installation or servicing other than that specified in this owner's manual unless you are qualified to do so. Incorrect installation or servicing may result in a risk of electric shock, fire, or other safety hazard.

1.1 Safety Symbols

The following safety symbols have been placed throughout this manual to indicate dangerous conditions and important safety instructions.



WARNING: This symbol indicates that failure to take a specified action could result in physical harm to the user.



CAUTION: This symbol indicates that failure to take a specified action could result in damage to the equipment.



Info: This symbol indicates information that emphasizes or supplements important points of the main text.

1.2 General Safety

- All electrical work must be performed in accordance with local and national electrical codes.
- This product is designed for indoor/compartment installation. It must not be exposed to rain, snow, moisture, or liquids of any type.
- Use insulated tools to reduce the chance of electrical shock or accidental short circuits.
- Remove all jewelry such as rings, watches, bracelets, etc., when installing or performing maintenance on the inverter.
- Both AC and DC overcurrent protection must be provided as part of the installation.
- Use Class 1 wiring methods for field wiring connections to terminals of a Class 2 circuit.
- Listed or labeled equipment shall be installed and used in accordance with any instructions included in the listing or labeling.
- To reduce risk of electric shock, disconnect all wiring before attempting any maintenance or cleaning. Turning off the inverter will not reduce this risk, the inverter bypass must be used or the panel should be totally disconnected from all sources.
- All wiring must have a minimum rating of 150V, 75°C when using 120V AC inverters; or 300V, 75°C when using 120V/240V AC inverters.
- AC wiring must be no less than 10 AWG (5.3 mm²) gauge copper wire.
- Battery cables should be no less than #4/0 AWG unless fused close to the battery bank for smaller sized cables.
- Crimped and sealed copper ring terminal lugs with a 3/8" hole should be used to connect to the DC terminals inside the MP enclosure. Soldered cable lugs are also acceptable.
- Torque all AC wiring connections and DC cable connections to the required torque values.

READ AND SAVE THESE INSTRUCTIONS

1.3 Battery Safety

IMPORTANT BATTERY SAFETY INSTRUCTIONS

- Be very careful when working around batteries, they can produce extremely high currents if short-circuited. Read the battery supplier's precautions before installing and connecting the inverter and batteries.
- Wear eye protection such as safety glasses when working with batteries.
- Remove all jewelry such as rings, watches, bracelets, etc., when installing or performing maintenance on the batteries.
- Never work alone. Always have someone near you when working around batteries.
- Use proper lifting techniques when working with batteries.
- Never use old or untested batteries. Check each battery's label for age, type, and date code to ensure all batteries are identical.
- Batteries are sensitive to changes in temperature. Always install batteries in a stable environment.
- Install batteries in a well ventilated area. Batteries can produce explosive gasses. For compartment or enclosure installations, always vent batteries to the outside.
- Provide at least one inch of air space between batteries to provide optimum cooling.
- Never smoke when in the vicinity of batteries.
- To prevent a spark at the battery and reduce the chance of explosion, always connect the cables to the batteries first. Then connect the cables to the MP enclosure/inverter system.
- Use insulated tools at all times.
- Always verify proper polarity and voltage before connecting the batteries to the MP enclosure/inverter system.
- To reduce the chance of fire or explosion, do not short across the battery terminal.
- In the event of accidental exposure to battery acid, wash thoroughly with soap and water. In the event of exposure to the eyes, flood them for at least 15 minutes with running water and seek immediate medical attention.
- Recycle old batteries.
- Be extra cautious to reduce the risk of dropping a metal tool onto batteries. It could short-circuit the batteries or other electrical parts, resulting in sparks that could cause an explosion.
- Cover the terminals to prevent accidental shorting.

READ AND SAVE THESE INSTRUCTIONS

2.0 Introduction

The MPX Series Extension Kit provides the necessary equipment to mount and connect an additional Magnum inverter to a MP Series enclosure and panel. The MPX is designed to allow a Magnum inverter to fit seamlessly into the top.

IMPORTANT: If you have not yet installed any of your system (i.e., MP enclosure, first inverter), refer to the MP Owner's Manual (PN: 64-0028) for initial setup instructions.

2.1 MPX Series Kit

Carefully remove the MPX from its shipping container and inspect all contents. Verify the below items are included. Contact your authorized Magnum Energy dealer or Magnum Energy if anything is missing. Save your proof-of-purchase as a record of your ownership (needed for in-warranty service).

The MPX kit includes (see Figure 2-1):

- | | |
|--|---|
| <p>A MPX extension box</p> <p>B Inverter hood - for vertically mounting an inverter</p> <p>C DC disconnect breaker - 250 ADC</p> <p>D AC breaker - 30 AAC double-pole (60 AAC single-pole with MPXS-60S)</p> <p>E DC positive/negative 2/0 AWG battery cables (see Table 2-1)</p> <p>F MPX AC Wiring Kit - for wiring to the AC terminals in MP panels (see Table 2-1)</p> | <p>G Remote cable (300V) - for installing remote control or router</p> <p>H Stacking cable - for series stacking MS4024 inverters or parallel stacking MS-PAE inverters</p> <p>See Note* on stacking cables below.</p> <p>I Labels and mounting hardware (Figure 2-2)</p> <p>J MPX Series Owner's Manual</p> <p>K Series Stacking Manual (MPXS-60S models only)</p> |
|--|---|

Note* - The supplied parallel stacking cables **must** be used when installing the router. They are like standard CAT 5 cables, but are rated for 300V to allow their use with the MS-PAE inverters and to meet electrical safety code requirements.

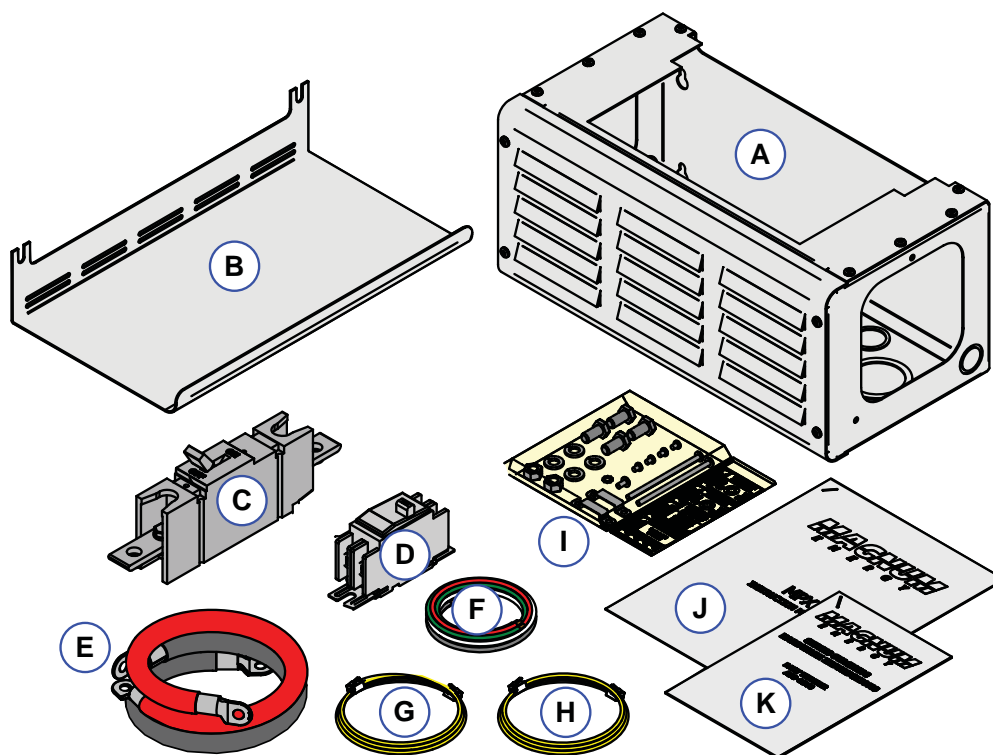
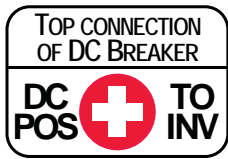
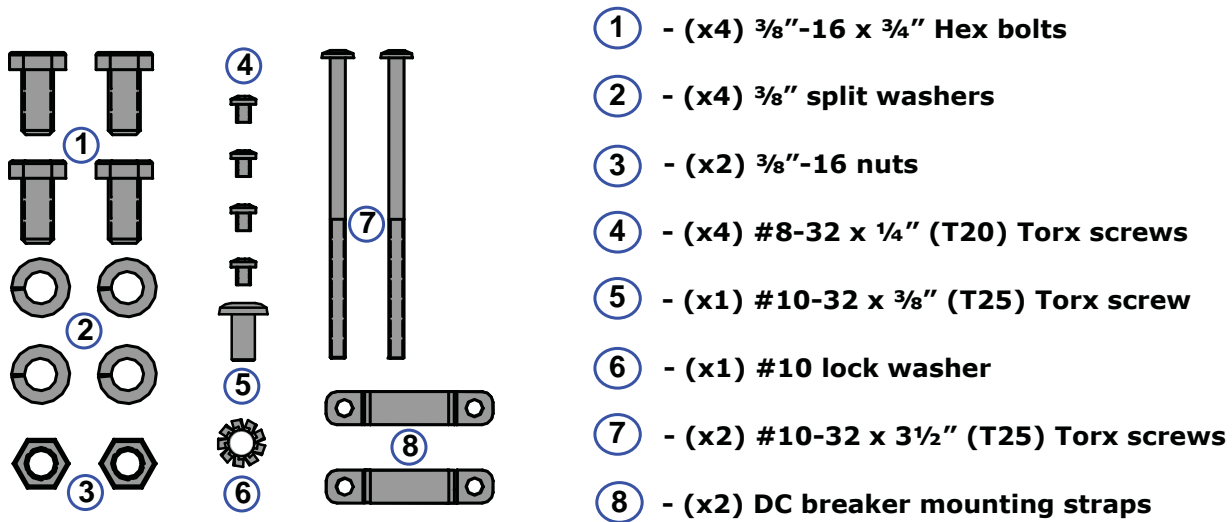
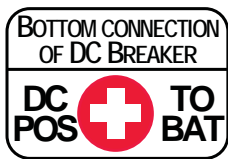

Figure 2-1, MPX Series Kit

2.0 Introduction



DC POS Top Connection



DC POS Bottom Connection

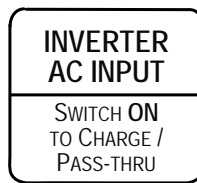

Inverter AC Input Label

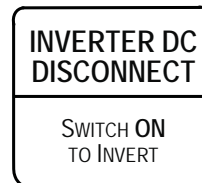

Inverter DC Disconnect Label

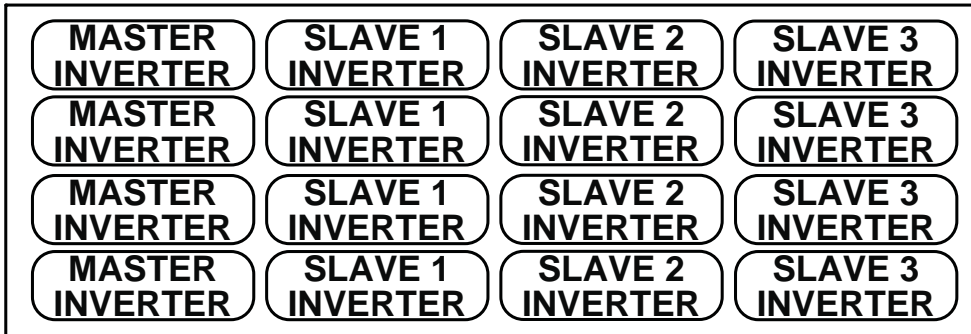

Master/Slave Labels

Figure 2-2, MPX Kit Labels and Hardware

| TABLE 2-1, MPX AC WIRE KIT PART NUMBERS | | | |
|---|-------------------------------|----------------------------|-------------------------------|
| AC Wire Function | A80-MPXS-30D | A80-MPXS-60S | A80-MPXD-30D |
| INV HOT 1 IN | #10 AWG Black (45")* | NA | #10 AWG Black (55")* |
| INV HOT 2 IN | #10 AWG Red (45")* | #6 AWG Red (45")* | #10 AWG Red (55")* |
| INV HOT 1 OUT | #10 AWG Black w/Stripe (45")* | NA | #10 AWG Black w/Stripe (55")* |
| INV HOT 2 OUT | #10 AWG Red w/Stripe (45")* | #6 AWG Red w/Stripe (45")* | #10 AWG Red w/Stripe (55")* |
| INV NEUTRAL IN | #10 AWG White (38") | #6 AWG White (38") | #10 AWG White (48") |
| INV NEUTRAL OUT | NA | #6 AWG White (38") | NA |
| INV AC GROUND | #10 AWG Green (38") | #10 AWG Green (38") | #10 AWG Green (48") |

* this wire is longer than needed to allow at least 7" to be cut and used for connecting to the inverter AC input breakers

| TABLE 2-2, DC 2/0 BATTERY CABLE LENGTHS | | |
|---|-------------|-----------|
| Model | Black Cable | Red Cable |
| MPXS-30D-L | 23.25" | 21.00" |
| MPXS-30D-R | 15.25" | 16.50" |
| MPXS-60S-L | 23.25" | 21.00" |
| MPXS-60S-R | 15.25" | 16.50" |
| MPXD-30D-L | 39.00" | 26.75" |
| MPXD-30D-R | 14.75" | 24.25" |

2.2 Available MPX Models

The three models in the MPX Series are: the MPXS-30D, MPXS-60S, and the MPXD-30D (see Figures 2-3 to 2-5). The MPXS-30D model is designed for use with a single MP enclosure (MPSL-30D and MPSH-30D), the MPXS-60S is only used with the MPSL-60S, while the MPXD-30D is designed for use with a dual MP enclosure (MPDH-30D). Each model comes in a left (L) and right (R) version. The 'right' version (MPXS-30D-R, MPXS-60S-R, or MPXD-30D-R) is used when the MPX is mounted to the right of the MP enclosure, and the 'left' version (MPXS-30D-L, MPXS-60S-L, or MPXD-30D-L) is used when the MPX is mounted to the left of the MP enclosure. The left version differs from the right only in that the length of the supplied DC cables are different to accommodate the difference in distance from the MP's DC breaker to the new installed inverter.



Info: The MPXS-60S model is unique in that it provides #6 AC wiring and a single-pole 60 AAC breaker, rather than the #10 AC wiring and 30 AAC double-pole breaker that comes with the MPXS-30D and MPXD-30D models.

| TABLE 2-3, MPX MODELS | | | |
|-----------------------|---------------------------------------|-------------------|--|
| MPX Model | Versions (left or right installation) | Used With: | |
| | | MP Enclosure | Inverters |
| MPXS-30D | MPXS-30D-L/MPXS-30D-R | MPSL-30D/MPSH-30D | MS4024PAE or MS4448PAE stacked in parallel |
| MPXS-60S | MPXS-60S-L/MPXS-60S-R | MPSL-60S | MS4024 stacked in series |
| MPXD-30D | MPXD-30D-L/MPXD-30D-R | MPDH-30D | MS4024PAE or MS4448PAE stacked in parallel |

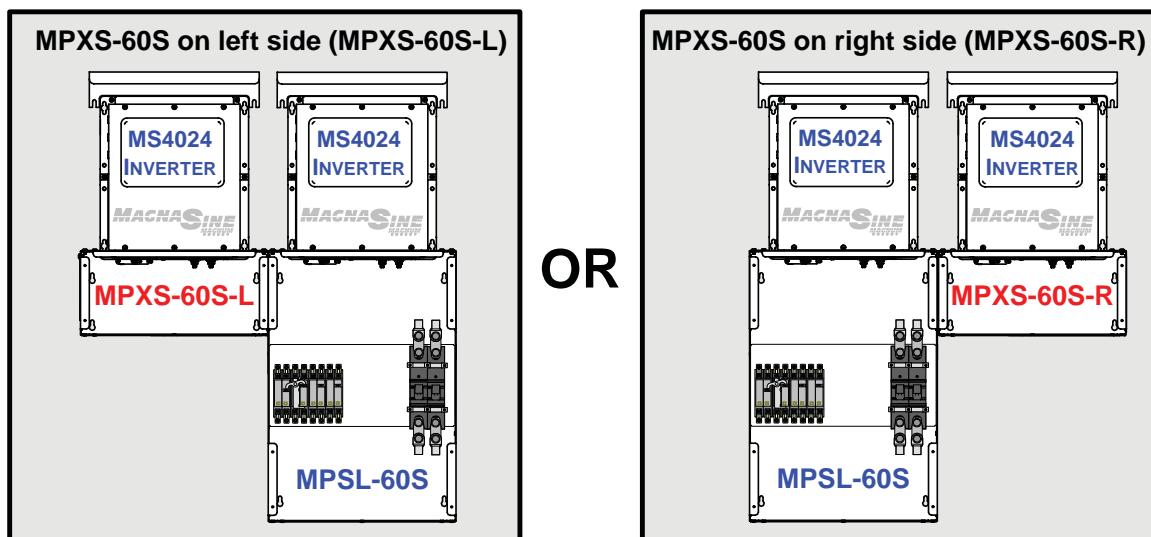

Figure 2-3, MPXS-60S Installation Configurations

2.0 Introduction

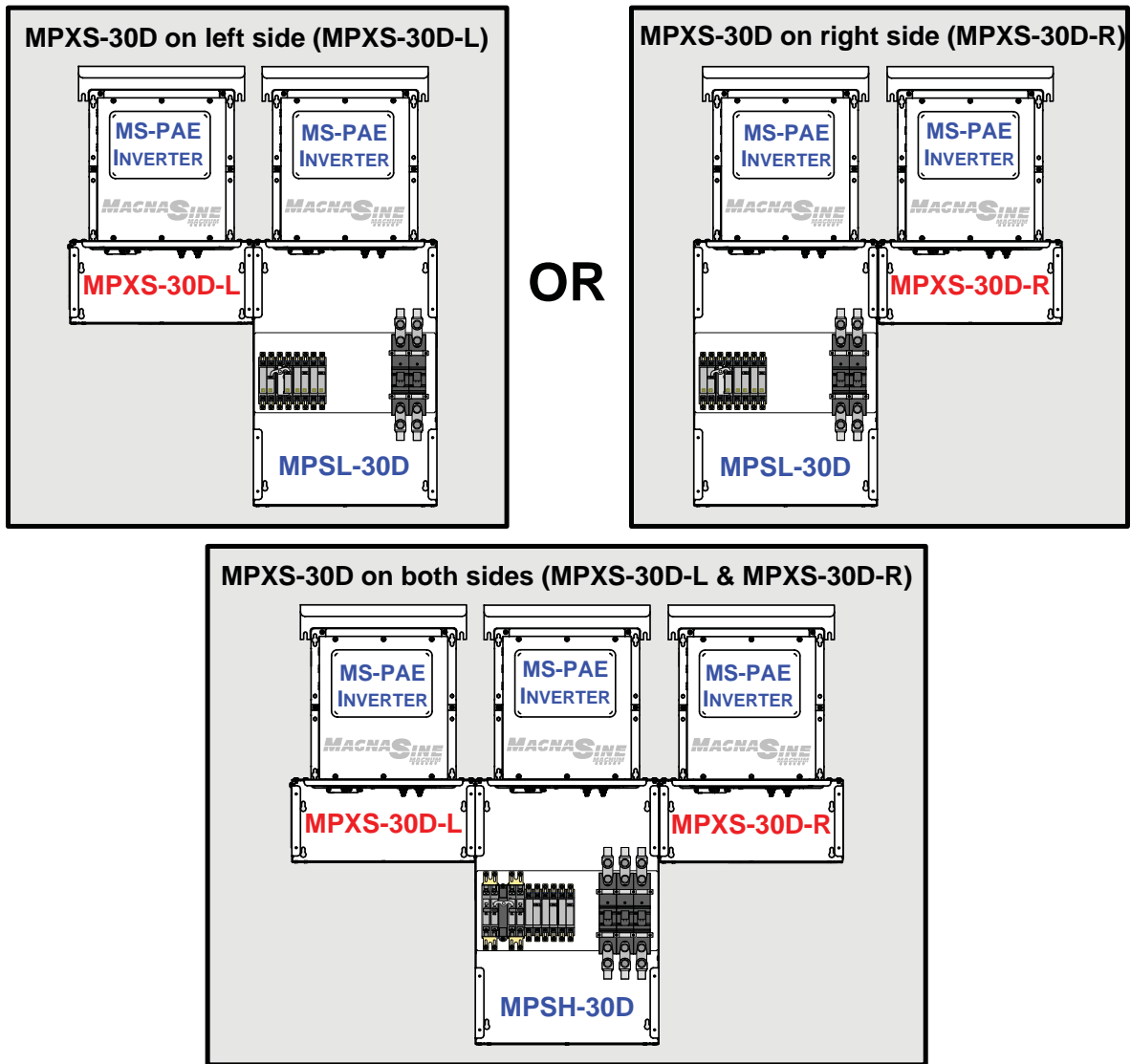

Figure 2-4, MPXS-30D Installation Configurations

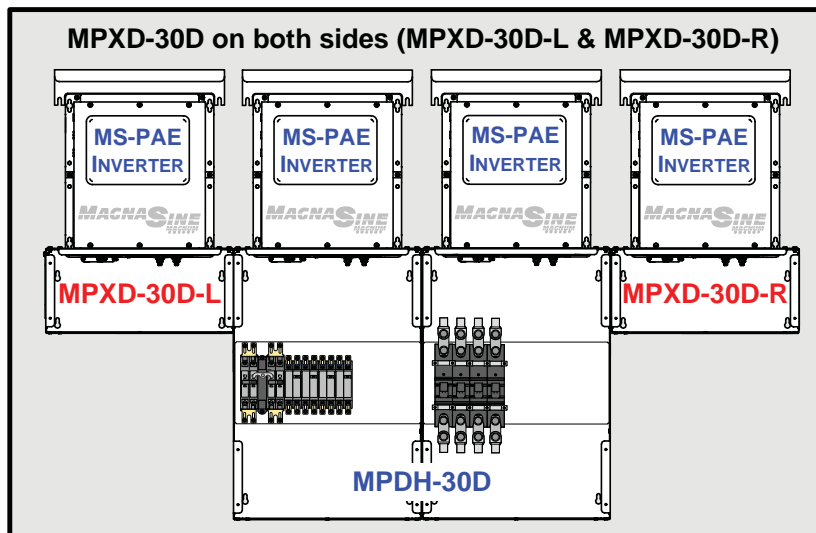

Figure 2-5, MPXD-30D Installation Configuration

3.0 Installation

3.1 Installing the MPX



Info: Installations should be performed by qualified personnel, such as a licensed or certified electrician. It is the installer's responsibility to determine which safety codes apply and to ensure that all applicable installation requirements are followed. Applicable installation codes vary depending on the location and application of the installation.



WARNING: This manual **does not** cover all the relevant safety instructions for your entire MP/MPX system. Review the safety information on pages 1 and 2 of this manual. Refer to the MP Owner's Manual (PN: 64-0028) **prior** to installing the MPX extension.



CAUTION: The MPX/MP enclosures and the inverters are heavy. Remember to use proper lifting techniques during installation to prevent personal injury.

3.1.1 Preparation

Before proceeding, read the entire Installation section to determine how you are going to install your MPX extension. The more thorough you plan in the beginning the more time you will save. Proper planning will also help you avoid common, costly mistakes.

Required Materials and Tools

Materials

- Conduit, strain-reliefs, and appropriate fittings
- Electrical tape
- Conductors/cables for wiring
- 1/4" mounting bolts & lock washers
- Wire ties

Tools

- Miscellaneous screwdrivers
- Drill and drill bits
- Level
- Torque wrenches
- Insulated pliers
- Pencil or marker
- 1/2" wrench
- Ratchet drives
- Wire cutters/strippers
- Multimeter
- Torx driver (T20,T25)

Location



Info: When possible, Magnum Energy recommends that if you are installing only one MPX it should be mounted to the left of the MP enclosure. Mounting the MPX on the right may prevent you from adding certain manufacturers' charge controllers in the future.

Only install your enclosure/inverter system in a location that meets the following requirements:

Clean and Dry - System must be mounted indoors in a relatively cool, clean, and dry environment.

Ventilation - If installed on the MP enclosure or MPX, the inverters pull in air through the intake vents. In order to provide full output power and avoid over-temperature fault conditions do not cover or block the MPX/MP enclosures' ventilation openings, or install it in an area with limited airflow. At the minimum, allow 3 inches of clearance to the left and right sides of the MPX/MP enclosures.

Close to the Battery Bank - Locate system as close to the batteries as possible. This ensures the battery cable length is kept as short as possible. Long DC wires tend to lose efficiency and reduce the overall performance of an inverter. However, the MPX/MP enclosures, inverter, and any other equipment that can spark (or that corrosion could damage) should not be installed in the same compartment/room as the batteries or mounted where it will be exposed to battery gases. These gases are corrosive and will damage this equipment; also, if these gases are not ventilated and if allowed to collect, they could ignite and cause an explosion. Consult your battery supplier for proper installation requirements.



Info: Consult your inverter owner's manual to determine the proper inverter-to-battery cable size for the distance that is used. However, this cable must not be sized any smaller than 0000 (4/0) AWG if the DC disconnect breaker in the MP enclosure will also be used as the overcurrent device. If a cable smaller than 4/0 AWG is used, an appropriately sized fuse must be installed to provide overcurrent protection to this smaller cable.

3.0 Installation

Safe - Keep any flammable/combustible material (e.g., paper, cloth, plastic, etc.,) that may be ignited by heat, sparks or flames at a minimum distance of 12 feet away from the MPX/inverter system. Do not install the MPX/MP/inverter system in any area that contains extremely flammable liquids like gasoline or propane, or in locations that require ignition-protected devices. Sparks from relays, circuit breakers, etc., could ignite the fumes or spills.

Accessible - Do not block access to the front of your system. Maintain at least a 36" (91 cm) clear space in front to access the AC and DC wiring terminals and connections inside the MPX/MP enclosure, as they will need to be checked and tightened periodically.

Removing the MPX's Front Cover

Remove the front cover on the MPX extension using a T25 Torx screwdriver. The screws are #10-32 x 3/8" Pan head, T25 Torx drive, thread cutting screws and the washers are #10 external tooth Star washers. You will need to reattach the MPX cover once all wiring is completed and tested.

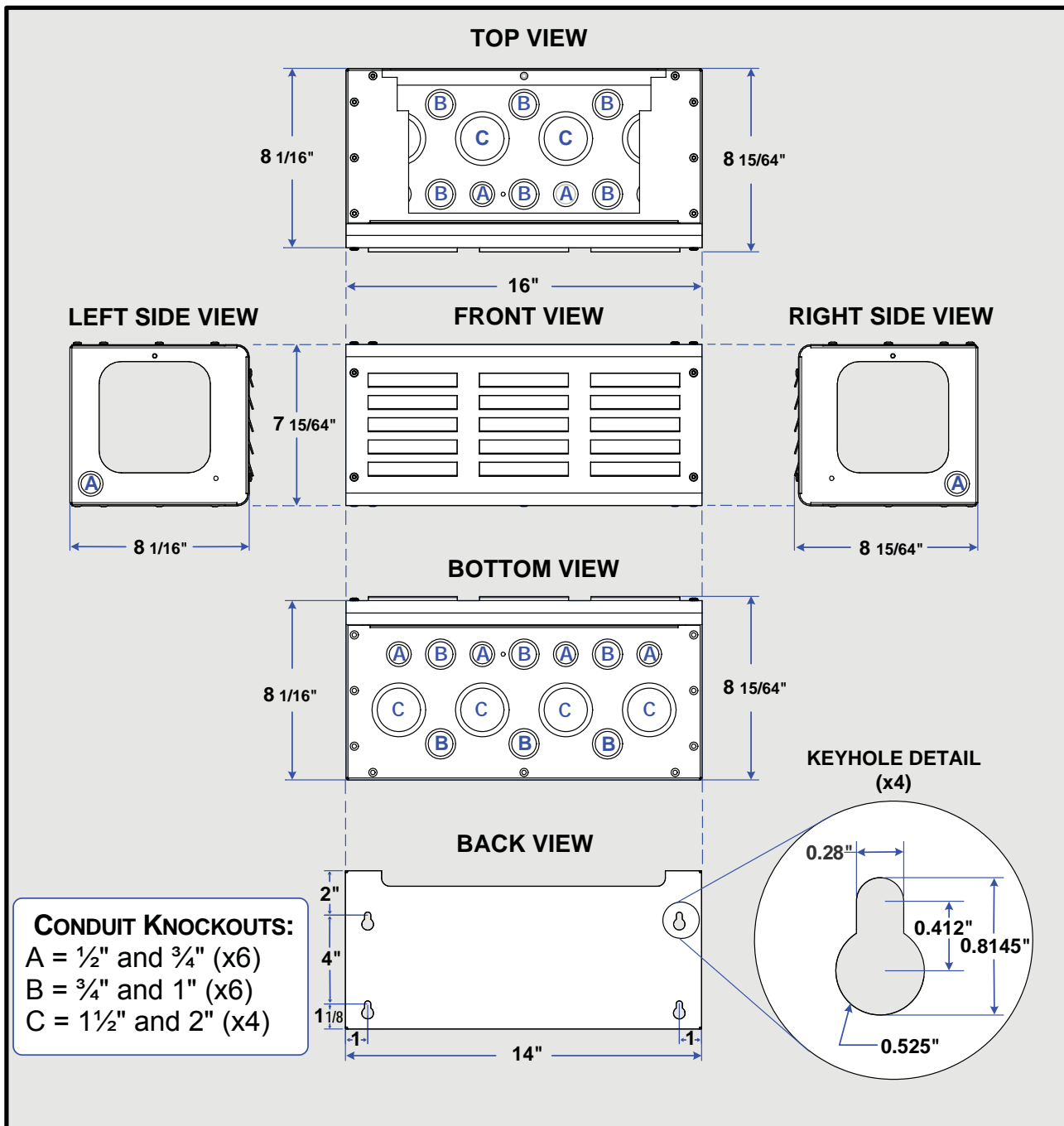

Figure 3-1, MPX Series Dimensions and Knockout Locations/Sizes

Conduit Knockouts



Info: Knockouts can be easily removed by tapping the edge with a straight bladed screwdriver and a hammer, then twist out with pliers; refer to Figure 3-2. Ensure that no debris remains inside the MPX after removing the knockouts.

The MPX comes standard with knockouts for 1/2", 3/4", 1", 1 1/2", and 2" conduits. Refer to Figure 3-1 for the location of these conduit knockouts. Select the appropriate knockout that is closest to the terminal to which you are running the cable/wire (see Figures 3-1 and 3-3).



Info: Identify and remove whatever MPX knockouts you will need for your installation prior to attaching the MPX to the MP enclosure. It is much easier to do this now rather than once the MPX is attached.

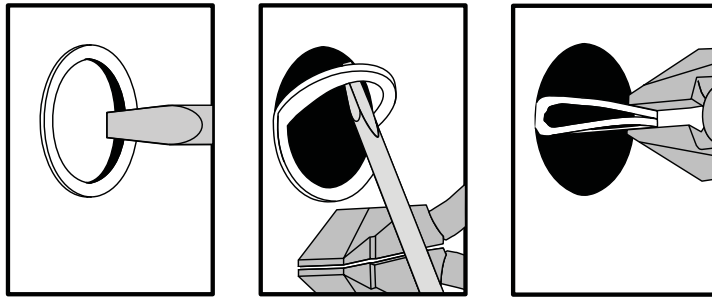
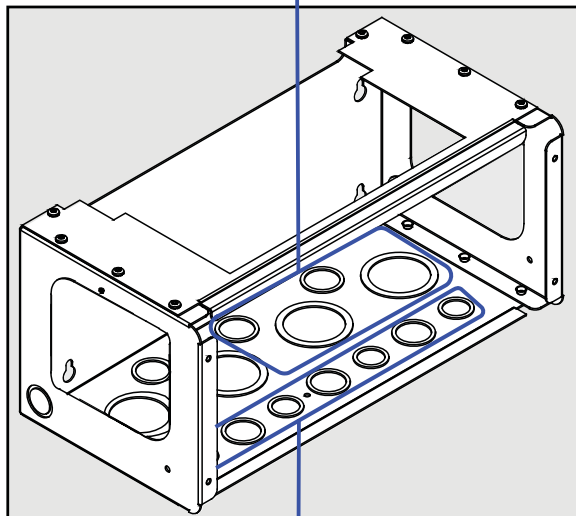

Figure 3-2, Removing a Knockout

Remove one of these knockouts in order to run the communication cables from the router to the inverters.



Do not remove any these front knockouts if the router* is attached to the MPX (see also Figure 3-4).

** The router and bracket are only used if inverters are to be parallel stacked.*

Figure 3-3, Removing MPX Knockouts

Note: The RTR bracket below is shown mounted on the right side of the MPX. The bracket can also be mounted on the left side of the MPX.

Do **not** attach the RTR bracket to the MPX/MP enclosure at this time (the bracket will be attached later in Section 3.1.8).

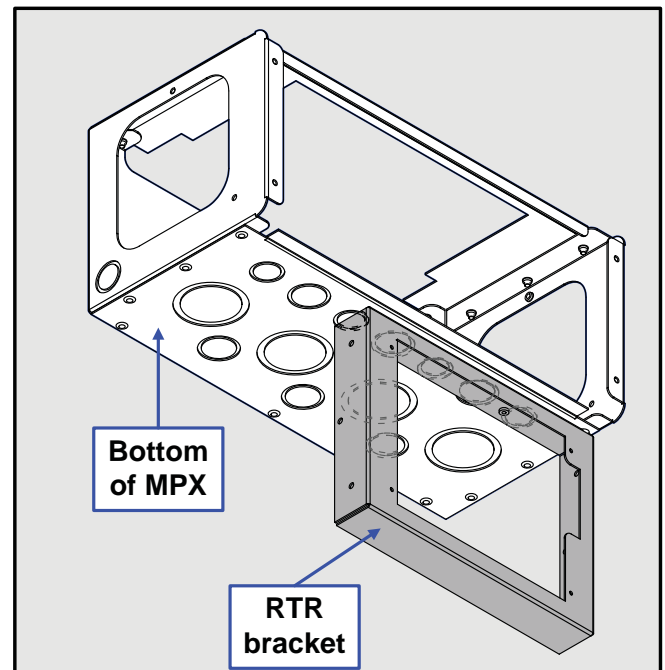

Figure 3-4, MPX with RTR Bracket

3.0 Installation

3.1.2 Attaching the MPX to the MP Enclosure

The MPX attaches to the MP enclosure. This provides unit stability when the MP enclosure is mounted to a backplate/sheathing, and also ensures good metal-to-metal contact for grounding the MPX and the MP enclosure together.

1. On the upper side of the MP enclosure, remove the side access plate – the side to which you will attach the MPX (see Figure 3-5).
2. Using the same screw and lock washer (see Item **A**), attach the side access plate to the side of the MPX (opposite the side of the MPX that attaches to the MP).

Note: Before attaching the MPX to the MP enclosure you should have already removed a knockout from the bottom of the MPX (see Figure 3-3). This knockout is needed for running the communication cables from the router to the inverters.

3. Use the supplied screw and lock washer (see Item **B**) to attach the MPX to the MP enclosure. The attachment hole is located towards the front of the (lower) side of the MPX.

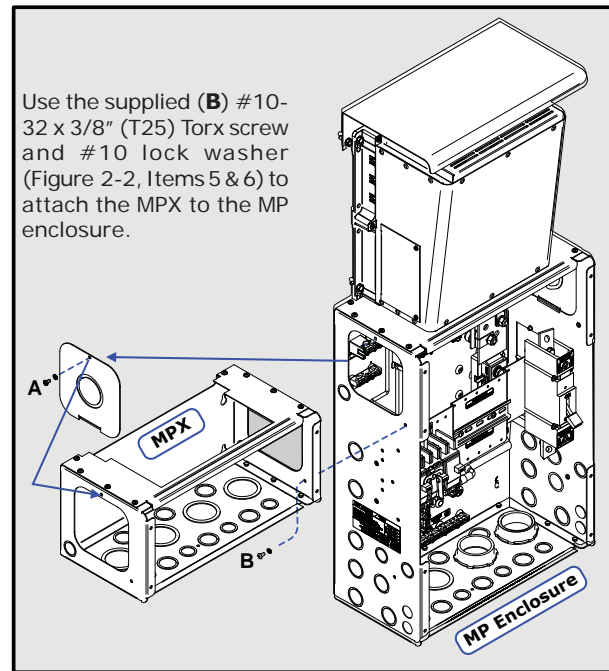

Figure 3-5, Attaching the MPX to an MP Enclosure

3.1.3 Mounting the MP/MPX Enclosure to a Backplate/Wall

The MP enclosure and attached MPX can be mounted on a Magnum backplate or a wall (see the MP Owner's Manual for wall requirements).

1. Using eight bolts, screw them halfway into the backplate/wall in the locations that the MP enclosure and attached MPX will be mounted (align with each unit's four keyhole slots).

Note: If you have purchased a Magnum dual or single backplate, you will be supplied with the necessary Hex head bolts (1/4-20 x 3/4") to mount the MP and MPX units to the backplate. If you are mounting to a wall, the installer must provide the appropriate mounting bolts.

2. Hang the MP enclosure and attached MPX onto the eight bolts using each unit's keyhole slots (see Figure 3-6).
3. Tighten the bolts to secure the MP enclosure and MPX onto the backplate/wall.

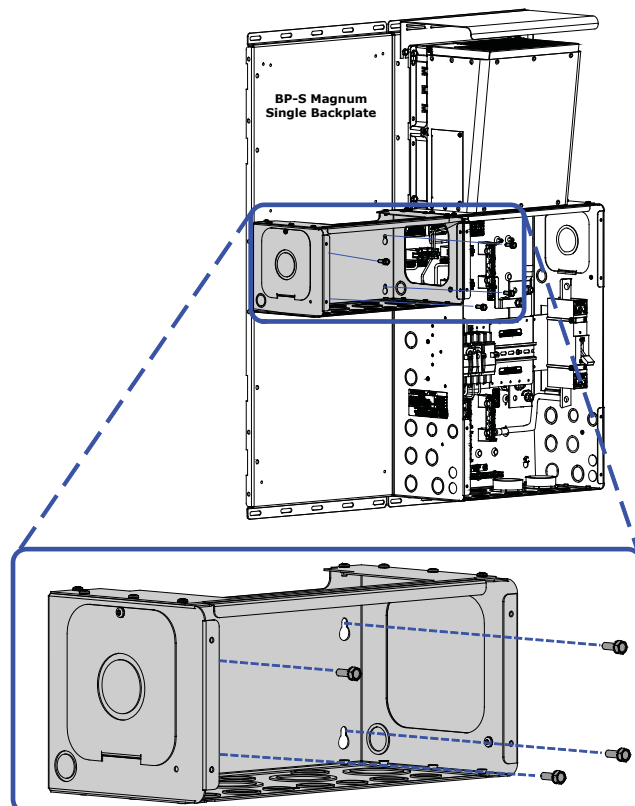

Figure 3-6, Mounting the MPX to a Backplate/Wall

3.1.4 Attaching the DC and AC Breakers



Info: The holes on the breaker mounting plate inside the MP enclosure — for Torx screws that hold the new DC and AC breakers — are NOT pre-threaded. Use a power driver to screw these self-threading screws into the mounting plate.



WARNING: During normal operation the terminals, busbars, and electrical components inside the MP enclosure may be energized - DO NOT TOUCH. Disconnect all power sources before removing the cover.

DC Breaker



CAUTION: The DC breakers must be mounted in a vertical position to meet the specified trip current and trip delay curve.

The DC breaker is attached within the MP enclosure and functions as the inverter's DC disconnect switch. The DC breaker can be used as the battery-to-inverter circuit protection in most installations.

1. Using a T25 screwdriver, remove two of the #10-32 x 3½" Torx screws that secure the existing DC breaker to the mounting plate – the removed screws should be the two that are adjacent to where the new DC breaker will be mounted (see Figure 3-7).
2. Place the new DC breaker against the MP's mounting plate and next to the existing DC breaker where the two mounting straps are loose.
3. While holding the new DC breaker in place, fit two new mounting straps over the new DC breaker. Ensure the holes on the new mounting straps — that are over the new DC breaker — line up with the holes of the adjacent two existing mounting straps (see Figure 3-8).
4. Insert the two Torx screws that were removed in Step 1 into the aligned holes of the new and existing mounting straps on the adjacent sides of the breakers, and then tighten to secure the existing DC breaker. Insert two new #10-32 x 3½" Torx screws into the other side of the new mounting straps and tighten enough to hold the new DC breaker in place. Do not fully tighten the screws, that will be done in Step 5 after being aligned.
5. Check for proper breaker alignment by temporarily placing the MP's front panel cover over the DC breakers. If fit and alignment are correct, tighten all Torx screws to secure the new DC breaker.



CAUTION: Be careful not to over-tighten to the point of bending down the tabs on the mounting straps.

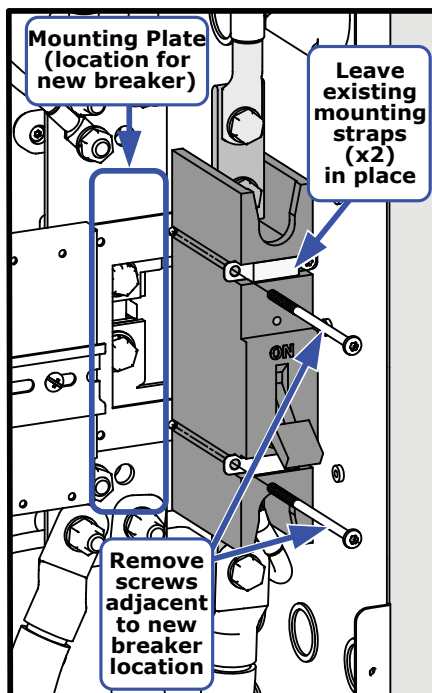

Note: Figure 3-8 includes the new breaker's DC wire connections. Actual connections occur in Section 3.2.

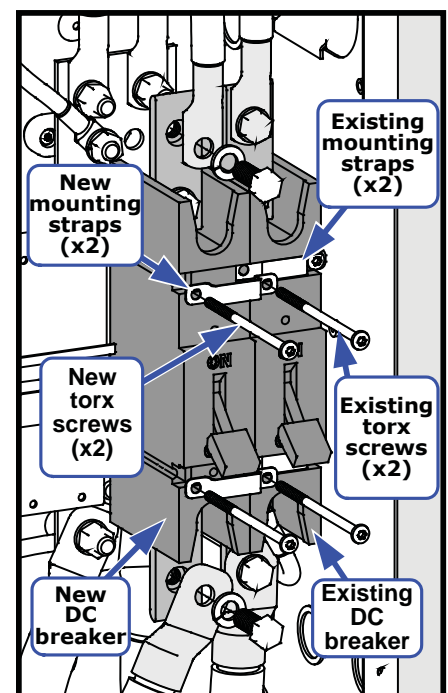

Fig. 3-7, Removing Breaker Screws Fig. 3-8, Attaching the New DC Breaker

3.0 Installation

AC Breaker

The AC breaker is attached within the MP enclosure and functions as the inverter's AC input disconnect switch.

1. While holding the new AC breaker against the MP's mounting plate, align the breaker's four mounting holes with the enclosure's mounting holes (see Figure 3-9). **Note:** The AC breakers are always installed in the left enclosure of a MP dual enclosure (see Figure 3-10).
2. Use the supplied four #8-32 x 1/4" T20 screws (Figure 2-2, Item 4) to hold the AC breaker in place. Do not fully tighten the screws, that will be done in the next step after ensuring proper alignment with the MP enclosure's cover.
3. Check the AC breaker alignment by temporarily placing the MP's front panel cover over the AC breakers. If the fit and alignment are correct, tighten all Torx screws to secure the new AC breaker.

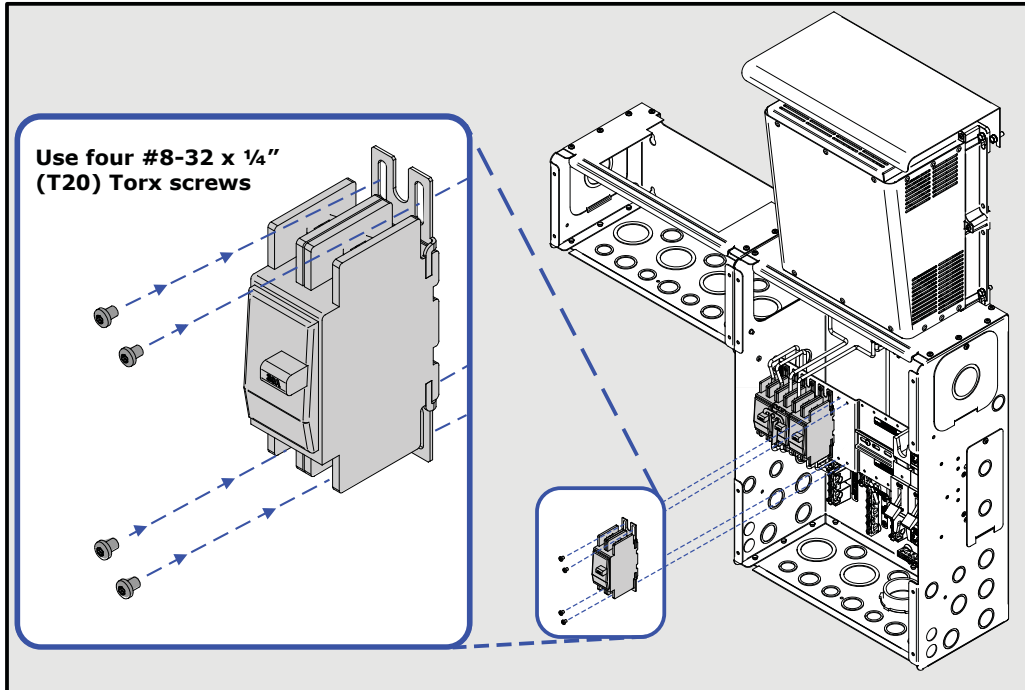

Figure 3-9, Attaching the New AC Breaker Within a MP Single Enclosure

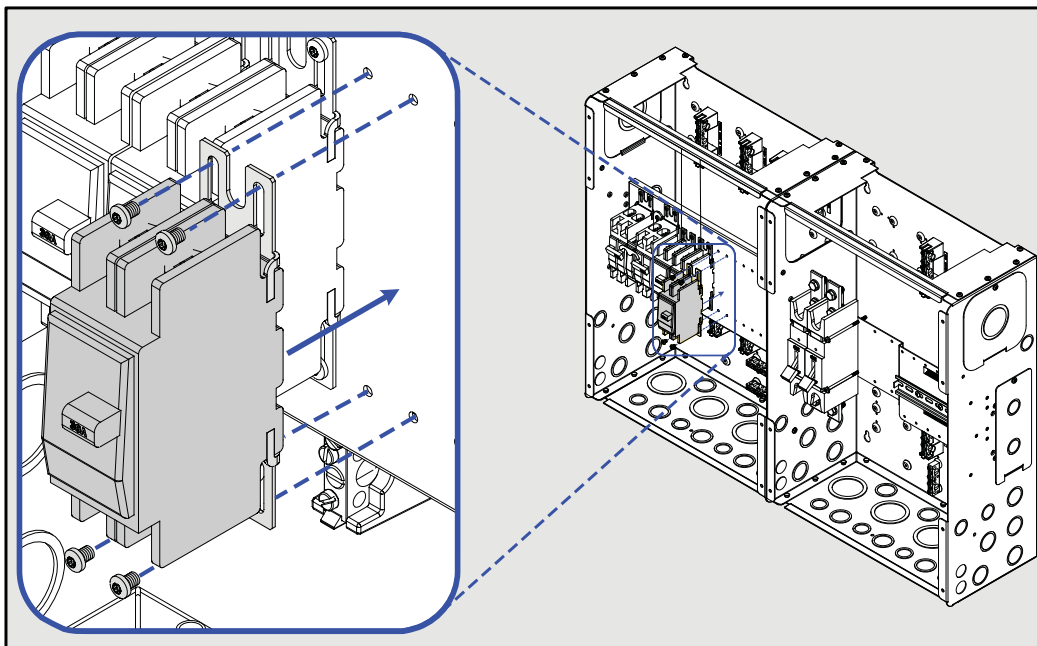

Figure 3-10, Attaching the New AC Breaker Within a MP Dual Enclosure

3.1.5 Connect and Separate Inverter AC Wires

Prior to mounting the second inverter on the MP enclosure, connect the AC wires provided in the MPX AC wire kit (see Figure 2-1, Item F and Table 2-1) to the inverter's AC wiring terminal (see the inverter owner's manual or the MP Owner's Manual for guidance in connecting the AC wires inside the inverter). Before connecting the AC wires, separate them into two wire bundles (inverter AC input and inverter AC output) to help ensure they are connected correctly after the inverter is mounted on the MP enclosure.

It is possible to connect these wires after the inverter is mounted. However, you have more space and easier access to the wiring terminal when the inverter's AC wires are connected before mounting – especially when installing multiple inverters side-by-side on an MP enclosure system. Replace the AC wiring access plate once you have connected the wires inside the inverter.

3.1.6 Mounting the Second Inverter onto the MPX

The additional inverter fits on top the MPX and is secured to the backplate/wall (Figures 3-11 & 3-12).

Note: Before mounting, pull the unconnected ends of the AC wiring outside of the inverter and through the MPX enclosure (see Figure 3-12).

1. Place the Magnum inverter on top of the MPX.
2. Secure it to the backplate/wall using four Hex head bolts and the inverter's keyhole slots.
3. Tighten the Hex head bolts to secure the inverter to the backplate/wall.

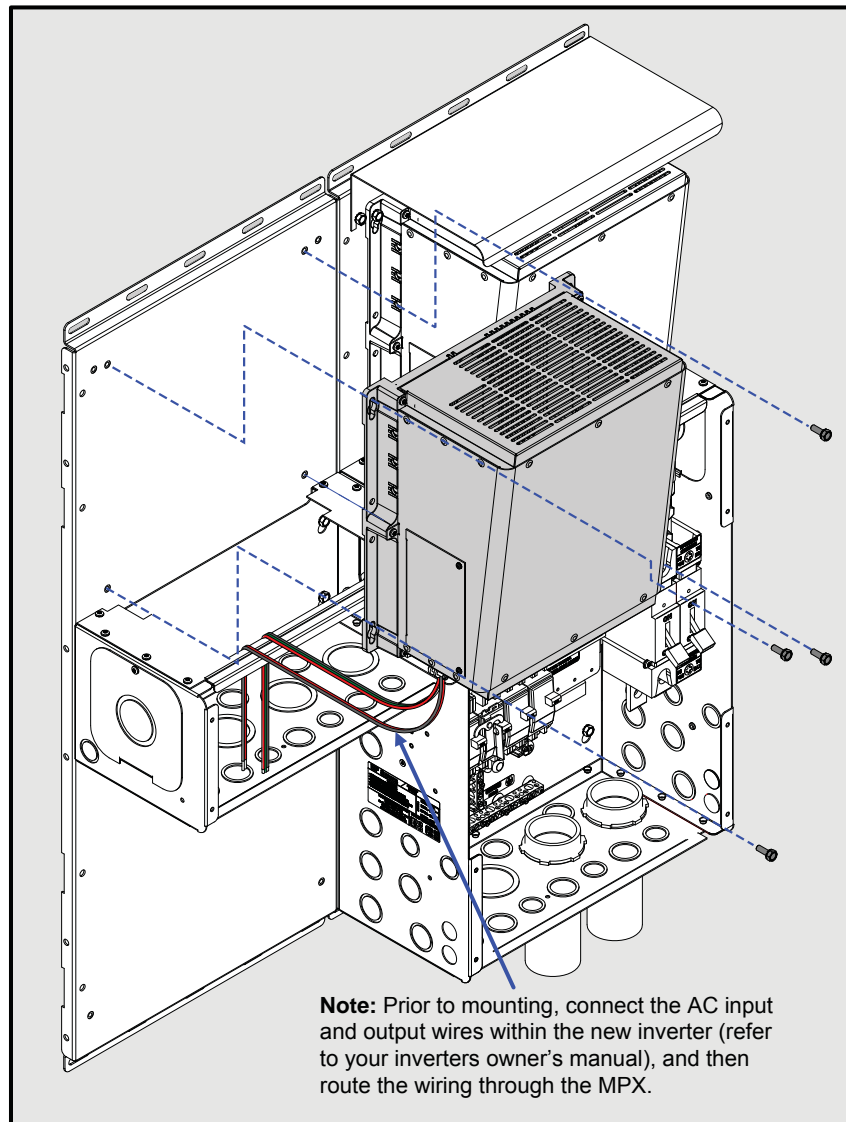

Figure 3-11, Mounting the Second Inverter on the MPX

3.0 Installation

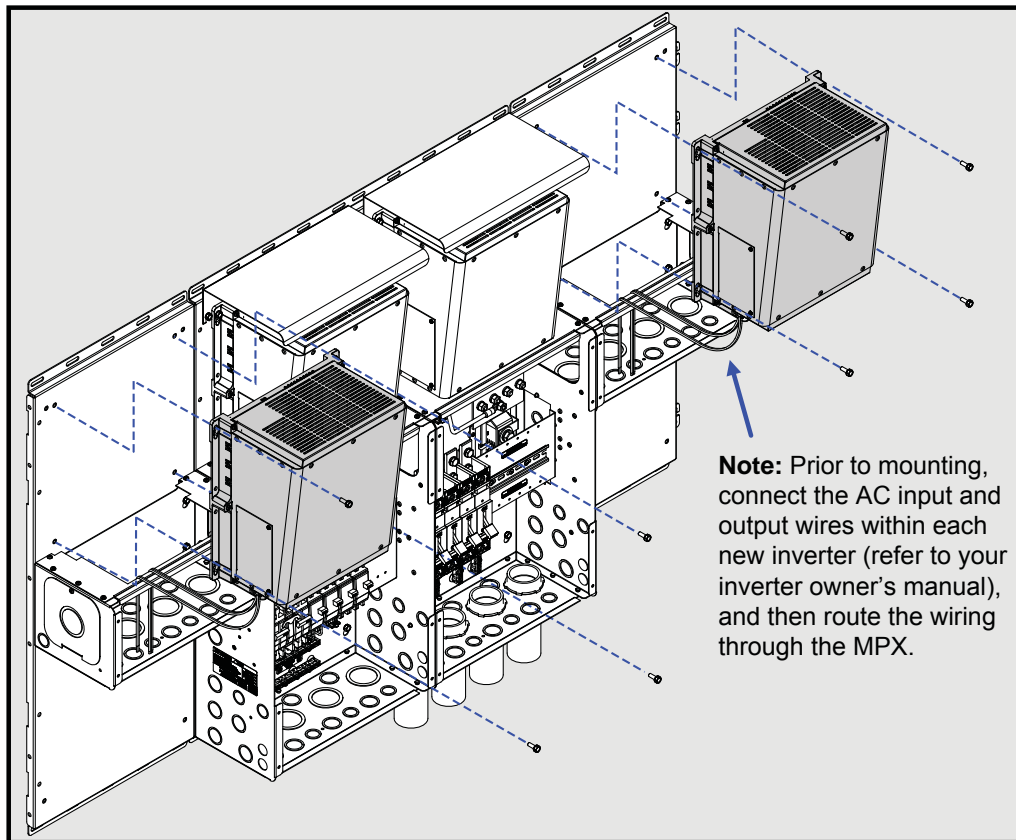

Figure 3-12, Mounting Multiple Inverters on the MPX

IMPORTANT: If the inverter is ever removed from the top of the MPX for service and the AC bypass breaker is used to continue to power the inverter loads, attach the knockout plate (provided with the MP enclosure) to the top of the MPX for use as a safety plate to prevent accidental access to live electrical circuits inside the MPX.



WARNING: If the knockout plate is used as a safety plate, the battery cables from the top of the DC disconnect must be prevented from touching the metal knockout plate or a short circuit to the battery bank may occur – causing lethal currents. Either remove these cables or isolate them (i.e., using electrical tape/rubber caps), do not rely **ONLY** on turning the DC disconnect switch to OFF.

3.1.7 Attaching the Inverter Hood

The inverter hood is designed to prevent objects from falling inside the top vents of the inverter, which can cause damage. For installations where the inverter is mounted on a vertical surface (DC terminals facing down) — such as a MP enclosure — the hood must be mounted above the inverter in order to meet UL regulatory requirements.



Info: The inverter hood does not mount to the inverter chassis, it must be mounted to the backplate/wall. Mounting bolts are included if a Magnum backplate has been purchased. If no backplate, the installer must supply the bolts – the mounting slots on the hood will accept up to a maximum 1/4" screw/bolt.



CAUTION: The inverter hood is not to be used as a drip shield to prevent water drops from entering the inverter.

Refer to Figures 3-13 & 3-14 to install the hood. The bottom edge of the hood must be mounted flush against the top of the inverter. This is the optimal position for minimizing the risk of objects falling into the inverter, and at the same time providing the clearance needed for air flow from the top vents of the inverter. **Do not** place anything on top of the inverter hood that might cause it to bend downward, or place anything on the sides that might restrict air flow through the inverter.

1. Screw two bolts/screws halfway into the backplate/wall where the hood will be mounted.
2. Place the inverter hood on these screws, and then tighten securely.

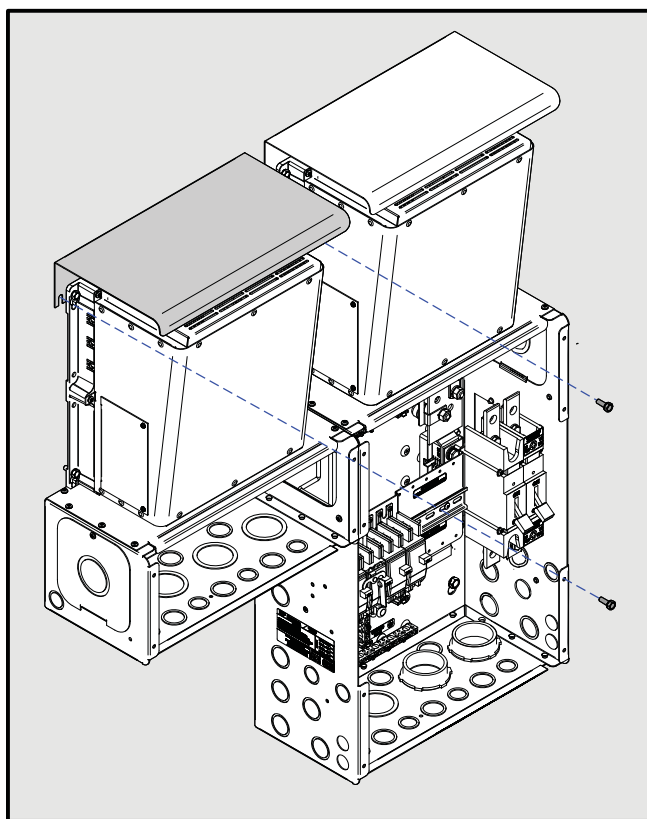

Figure 3-13, Attaching the Inverter Hood

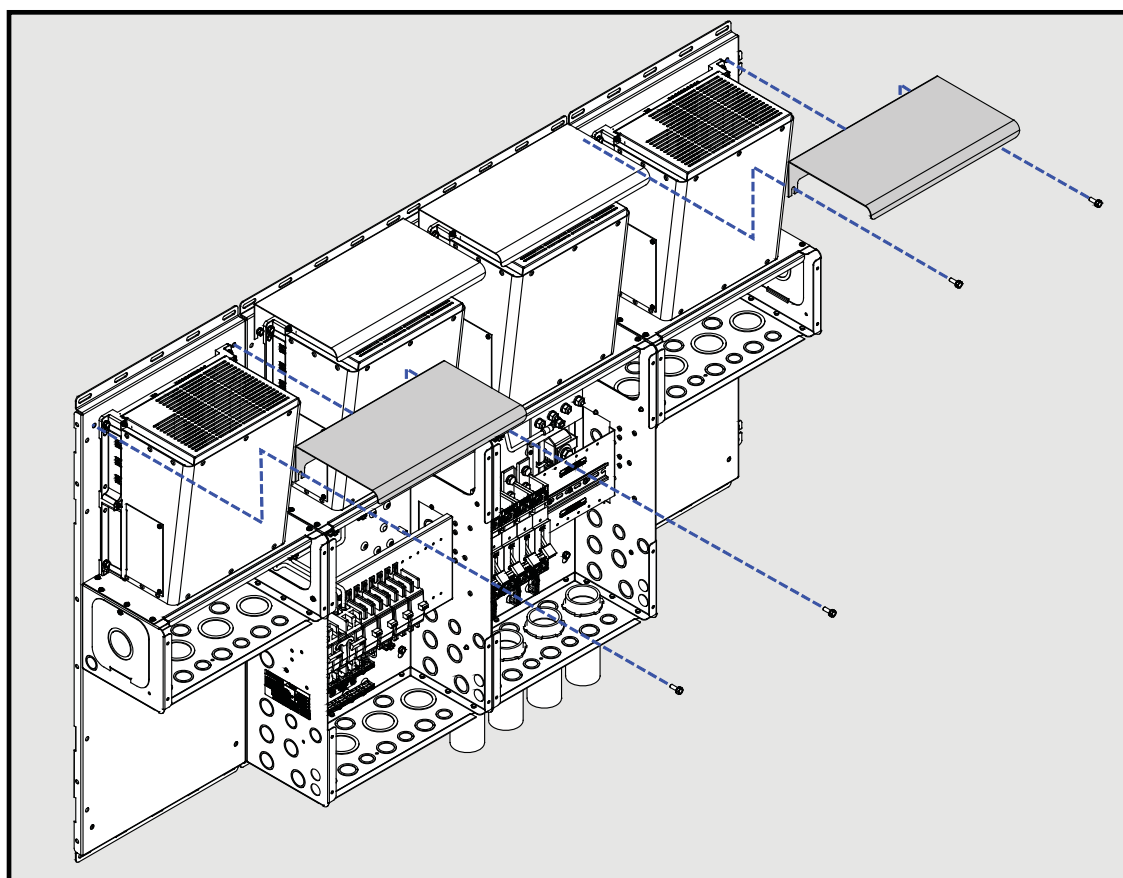

Figure 3-14, Attaching Multiple Inverter Hoods

3.0 Installation

3.1.8 Attaching the Router Bracket

The Magnum router can be easily attached to the MP and MPX enclosures using the router bracket. The router bracket comes with four screws (#8 x 32 x 3/8" T15 drive) for mounting; one for attaching the bracket to the MPX, and three for attaching the bracket to the MP enclosure (router bracket and hardware provided with MP enclosure). Refer to Figure 3-15.

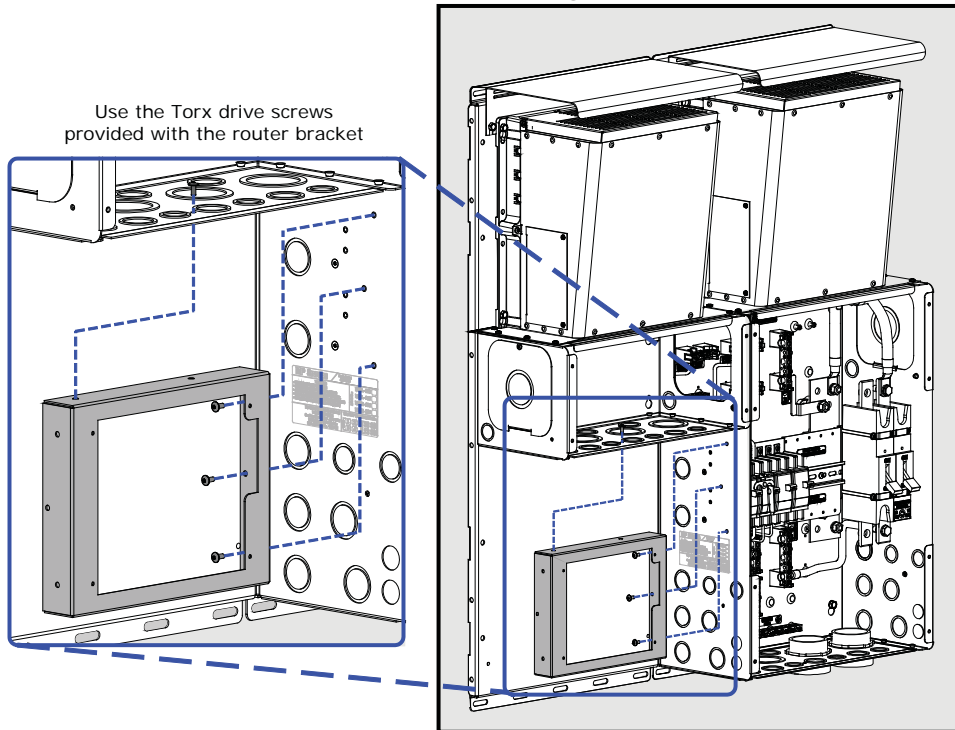

Figure 3-15, Attaching the Router Bracket

3.1.9 Attaching the Router to the Bracket

The router is easily attached to the router bracket using the four screws (#8-32 x 1/2" Phillips drive) in the router bracket kit provided with the MP enclosure. Refer to Figure 3-16 to attach the router to the bracket.

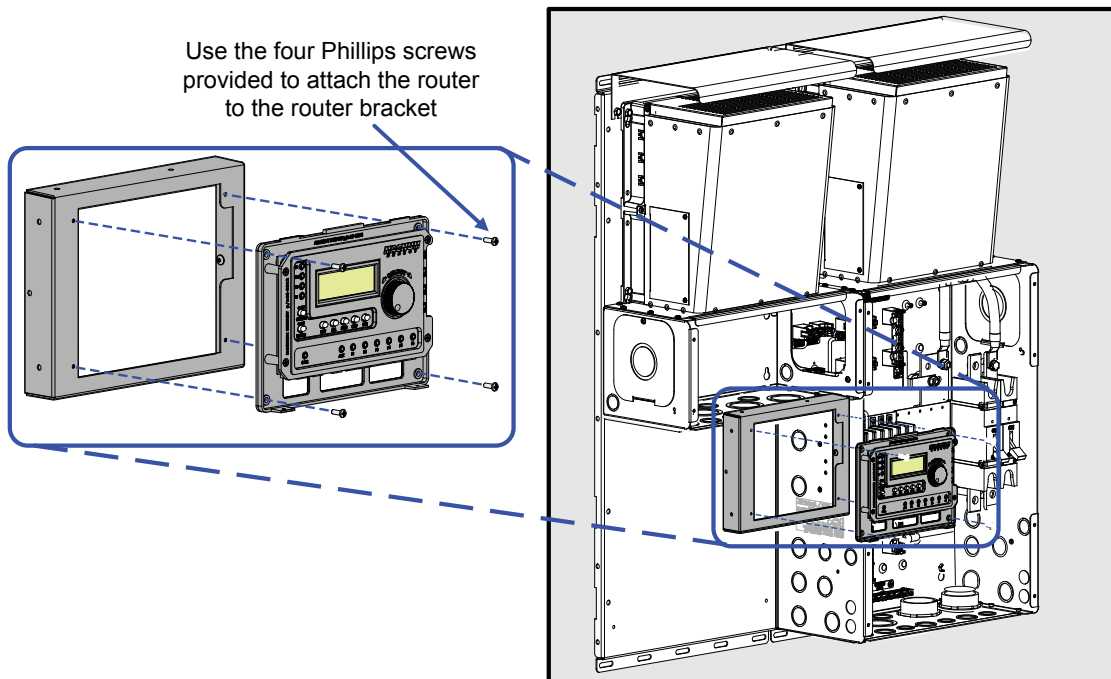

Figure 3-16, Attaching the Router to the Bracket

3.2 Wiring the MPX

This section covers installing AC, DC, and communication wiring for each MPX model (Table 3-1).

| TABLE 3-1, MPX WIRING TABLE | | | | | | |
|-----------------------------|-------------------------|--------------------|---------------------|--------------------|------------------------|-----------------------|
| MPX Model | MP Enclosure Used With: | Inverter AC Wiring | External* AC Wiring | Inverter DC Wiring | Battery Bank DC Wiring | Communications Wiring |
| MPXS-30D | MPSL-30D | Figure 3-18a | Figure 3-18b | Figure 3-18c | Figure 3-18d | Figure 3-18e |
| MPXS-30D | MPSH-30D | Figure 3-19a | Figure 3-19b | Figure 3-19c | Figure 3-19d | Figure 3-19e |
| MPXS-60S | MPSL-60S | Figure 3-21a | Figure 3-21b | Figure 3-21c | Figure 3-21d | Figure 3-21e |
| MPXD-30D | MPDH-30D | Figure 3-22a | Figure 3-22b | Figure 3-22c | Figure 3-22d | Figure 3-22e |

* - 'External' refers to wiring that is required outside the MP/MPX panel (i.e., wiring to loads, grid/gen input wiring)

3.2.1 Wiring Guidelines

This section provides general information on the AC wiring to/from the new inverter, from the incoming AC source, and to the outgoing AC distribution panel (i.e., inverter sub-panel).

IMPORTANT: All wiring should meet local codes and standards and be performed by qualified personnel such as a licensed electrician.



CAUTION: Before installing any AC wiring, review all safety information in the MP Owner's Manual (PN: 64-0028) and at the beginning of this manual, and the information below to ensure a safe system:

- The AC wires must be appropriately sized, and must be no less than #10 AWG (5.3 mm²) gauge copper wire and be approved for residential wiring.
- **DO NOT** connect the Magnum inverter's output to an AC power source. This could cause severe damage to the inverter and is not covered under warranty.



WARNING: To reduce the risk of fire, do not connect a 120V AC only inverter to both busbars in an AC load center (circuit breaker panel) having multi-wire branch circuits connected. Every circuit connected to a 120V AC panel must have its own neutral; otherwise, currents on shared neutrals will add rather than subtract – overloading the neutral conductor.

The AC and DC wires into and out of the MP enclosure and the MPX extension must be protected as required by code. This can be done by using jacketed wires or by feeding wires through conduit.



Info: If using a Magnum inverter, and the AC wires are individual conductors (i.e., not jacketed), the strain reliefs on the inverter can be replaced with 3/4" grommets.

- Use proper clamps or other approved methods for securing the cable/conduit to the enclosure.
- The MP enclosure is specifically approved/designed for both AC and DC wiring. However, where DC wiring must cross AC or vice-versa, try to make the wires at the crossing point 90° to one another.
- Use only copper wires with a minimum rating of 150V, 75°C if only 120V AC power is being used; or, with a minimum rating of 300V, 75°C if 120/240V AC power is being used.
- In a system where one conductor is grounded, the wire colors on the DC side and the AC side are the same. The insulation on all grounded conductors (DC negative/AC neutral) must be white, gray, or any color except green if marked with white at each termination (marking only allowed on 6 AWG or larger conductors). The equipment grounding conductors must be bare (no insulation), or have green or green with yellow-striped insulation or identification. The hot ungrounded conductor (DC positive/AC hot) is usually red or black.
- Terminals containing more than one conductor must be listed for multiple conductors.
- The connectors or terminals used on flexible, fine-stranded conductors must be specifically marked or labeled for use with fine-stranded conductors.
- The MPX/MP enclosures include wires (along with communication cables) with insulation rated for at least 300 volts, which allows 120/240V AC inverters to be installed. If installing a 120/240V AC inverter, the installer must also provide wires (both power and communication) with the insulation rated for at least 300 volts.

3.0 Installation

AC Connections

To view the AC connection points inside the MP enclosures, review Figures 3-18a/b and 3-19a/b for the MPLS-30D and MPLS-30D models, Figure 3-21a/b for the MPLS-60S model, or Figure 3-22a/b for MPDH-30D model.

If using an MS-PAE Series inverter, the full AC continuous pass-thru capacity of these inverters is 30 amps for each AC leg (AC LEG 1 and AC LEG 2), and requires a maximum 30 amp breaker on each AC input to protect the inverter's inputs. This correlates with the MPLS-30D, MPLS-30D, and the MPDH-30D enclosures, which include a dual 30 amp input inverter breaker and a minimum cable size of #10 AWG in conduit.

In MS4024 inverters, the AC LEG 1 and AC LEG 2 may be combined to obtain a 60 amps pass-thru capability. When tying the AC LEG 1 and AC LEG 2 together for a 60 amp continuous pass-thru capability, the AC input to the inverter requires a 60 amp breaker. This correlates with the MPLS-60S model, which includes a single 60 amp breaker and requires a minimum cable size of #6 AWG in conduit. Refer to Figure 3-20a for info on wiring to the MS4024 inverter.

If you are using other circuit breakers/wire sizes, refer to the appropriate electrical codes for proper sizing requirements.

DC Cable Connections

Before proceeding with the DC wiring, review the instructions in Figure 3-17 to ensure proper DC cable stacking and connections. Do not put anything between the DC cable ring lug and the battery terminal post or the flat metal part of the inverter's DC terminal. When connecting the DC cable to the battery or inverter DC terminals, the cable should be placed directly against the inverter or battery terminals. Incorrectly installed hardware causes a high resistance connection which could lead to poor inverter/charger performance, and may melt the cable and terminal connections.

Make sure to properly connect the DC cables and correctly stack the hardware. Tighten the terminal connections from 10 to 12 ft lbf (13.6 to 16.3 N-m).



CAUTION: The DC terminal and Flange/Kep nuts supplied with the inverter are made of stainless steel, which have a high likelihood of seizure. To help prevent the bolt and nut from seizing — causing the bolts to strip or snap/break-off — the use of anti-seize lubricant is highly recommended.



Info: If antioxidant grease or spray is used, apply it **after** all the connections have been made and are properly tightened.



Info: A 1/2-inch wrench or socket is used to tighten the 5/16-18 SAE Flange/Kep nuts.

IMPORTANT: Magnum accessories (ME-ARC, ME-RTR, ME-AGS, and ME-BMK) each use a communication chip to talk with the inverter. This communication chip is powered through the communication lines using the B+ (battery positive) and B- (battery negative) supply. We have found that customers are removing the battery negative circuit (B-) while the battery positive circuit (B+) is still connected; or, they are connecting the battery positive (B+) before connecting battery negative (B-). When accessories are connected to the inverter and B+ is connected or disconnected to the inverter without a return path (i.e., B-), the communication chips/lines become the DC return path to the battery — causing permanent damage to all connected accessories on the network.

You should not have any issue with communication circuits when using the MP/MPX panels. This is because when you open the Inverter Disconnect Breaker on the MP to power-down the system you are opening the B+ circuit while all B- circuits remain connected. Once the system is powered-down, you can connect and disconnect communication cables as needed. When you are finished removing/adding accessories and comm cables, you can turn the Inverter Disconnect Breaker back on to resume operation, which connects the B+ circuits (with B- circuits already connected).

In summary: Ensure all battery negative (B-) circuits are connected before connecting or disconnecting battery positive (B+).

INVERTER DC NEGATIVE AND POSITIVE CONNECTIONS

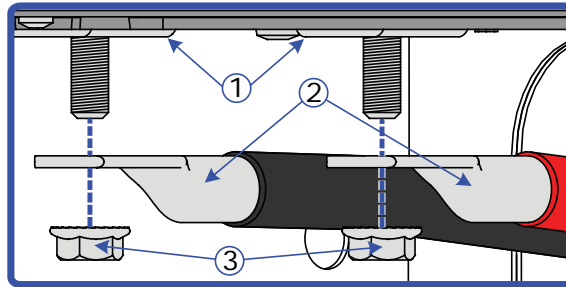

Inverter Hardware Stack-up:

- 1 Inverter DC terminals
- 2 Inverter cable lugs
[(-) to shunt busbar,
(+) to inverter DC breaker]
- 3 5/16-18 nut (Flange or Kep)

DO NOT place anything between the inverter DC terminals and the inverter cable lugs.

INVERTER NEGATIVE TO SHUNT BUSBAR (TOP) DC POSITIVE CONNECTION

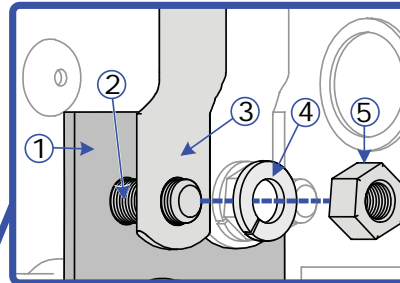

Top of Shunt Busbar Hardware Stack-up:

- 1 DC shunt busbar (top)
- 2 Hex bolt (3/8-16-3/4")
- 3 Negative (-) battery cable lug
- 4 Split-lock washer
- 5 3/8-16 nut

DO NOT place anything between the DC shunt busbar and the negative inverter cable lug.

INVERTER POSITIVE TO INVERTER DC BREAKER (TOP) CONNECTION

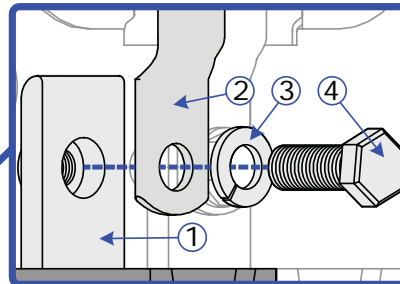

Top of DC Breaker Hardware Stack-up:

- 1 DC breaker (top) terminal
- 2 Positive (+) inverter cable lug
- 3 Split-lock washer
- 4 Hex bolt (3/8-16-3/4")

DO NOT place anything between the DC breaker terminal and the positive inverter cable lug.

BATTERY POSITIVE TO INVERTER DC BREAKER (BOTTOM) CONNECTION

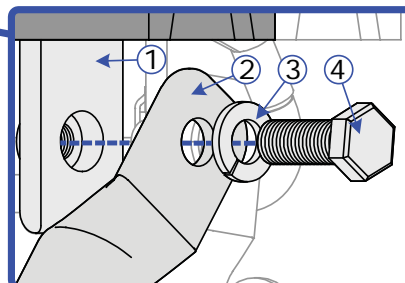

Bottom of DC Breaker Hardware Stack-up:

- 1 DC breaker (bottom) terminal
- 2 Positive (+) battery cable lug
- 3 Split-lock washer
- 4 Hex bolt (3/8-16-3/4")

DO NOT place anything between the DC breaker terminal and the positive battery cable lug.

BATTERY NEGATIVE TO SHUNT BUSBAR (BOTTOM) CONNECTION

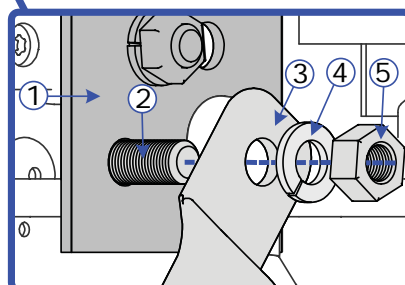

Bottom of Shunt Busbar Hardware Stack-up:

- 1 DC shunt busbar (bottom)
- 2 Hex bolt (3/8-16-3/4")
- 3 Negative (-) battery cable lug
- 4 Split-lock washer
- 5 3/8-16 nut

DO NOT place anything between the DC shunt busbar and the negative battery cable lug.

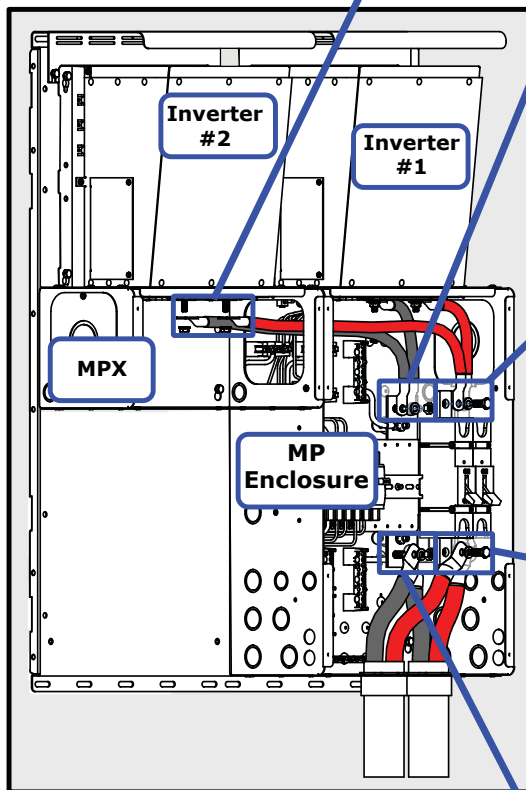

Figure 3-17, DC Cable Connections

3.0 Installation

3.2.2 Wiring the MPXS-30D

The following steps are basic guidelines for installing and connecting the AC, DC, and communication wiring for the MPXS-30D (used with MPSL-30D or MPSH-30D enclosures).



WARNING: To prevent electrical shock, make sure all AC power (inverter, generator, or utility) is off before making any AC connections inside the MP enclosure.

MPXS-30D AC Wiring

This section provides information on the AC wiring to/from the inverters, and to/from the main panel and sub-panel. The MPX kit includes strand B wires for wiring to the AC terminals in the MP enclosure. The HOT 1 and HOT 2 wires into/out of the inverter are longer than needed. This allows you to cut and use the two excess wire lengths (one black and one red, or one black w/stripe and one red w/stripe) for routing AC wires from the bottom of the AC breaker to the MP's busbar terminals. See Table 2-1 for AC wire size, color, length, and routing location.

Inverter AC Input Wiring (see Figure 3-18a - MPSL-30D, Figure 3-19a - MPSH-30D)

1. Route and attach a black wire from the top right terminal of each of the MP enclosure's new AC input breakers to each inverter's AC HOT 1 IN terminal (Master, Slave 1, and if MPSH-30D enclosure, Slave 2).
2. Route and attach a red wire from the top left terminal of each of the MP enclosure's new AC input breakers to each inverter's AC HOT 2 IN terminal.
3. Route and attach a green wire from the MP enclosure's GROUND busbar to each inverter's AC GROUND terminal.

Inverter AC Output Wiring (see Figure 3-18a - MPSL-30D, Figure 3-19a - MPSH-30D)

1. Route and attach a black w/white stripe wire from the MP enclosure's INV HOT 1 OUT busbar to each inverter's AC HOT 1 OUT terminal (Master, Slave 1, and if MPSH-30D enclosure, Slave 2).
2. Route and attach a red w/white stripe wire from the MP enclosure's INV HOT 2 OUT busbar to each inverter's AC HOT 2 OUT terminal.
3. Route a white wire from the MP enclosure's AC NEUTRAL busbar to each inverter's AC NEUTRAL terminal.

Bottom AC Breaker Wiring (see Figure 3-18b - MPSL-30D, Figure 3-19b - MPSH-30D)

1. Route and attach a black wire from the bottom right terminal of each of the new AC input breakers to the MP enclosure's AC LEG 1 IN busbar (Master, Slave 1, and if a MPSH-30D enclosure, Slave 2).
2. Route and attach a red wire from the bottom left terminal of each of the new AC input breakers to the MP enclosure's AC LEG 2 IN busbar.

External AC Main Panel Wiring (see Figure 3-18b - MPSL-30D, Figure 3-19b - MPSH-30D)

1. Route and attach a black wire from MP enclosure's AC LEG 1 IN busbar to the main AC electrical panel.
2. Route and attach a red wire from the MP enclosure's AC LEG 2 IN busbar to the main AC electrical panel.
3. Route and attach a green wire from the MP enclosure's GROUND busbar to the main AC electrical panel's Ground busbar.
4. Route and attach a white wire from the MP enclosure's AC NEUTRAL busbar to the main AC electrical panel's Neutral busbar.

External AC Sub-Panel Wiring (see Figure 3-18b - MPSL-30D, Figure 3-19b - MPSH-30D)

1. Route and attach a black wire from the MP enclosure's AC LEG 1 OUT busbar to the AC electrical sub-panel.
2. Route and attach a red wire from the MP enclosure's AC LEG 2 OUT busbar to the AC electrical sub-panel.
3. Route and attach a green wire from the MP enclosure's GROUND busbar to the AC electrical sub-panel's Ground busbar.
4. Route and attach a white wire from the MP enclosure's AC NEUTRAL busbar to the AC electrical sub-panel's Neutral busbar.

AC Wiring Inspection

After verifying all AC connections are correct — and all AC terminal screws are torqued correctly — replace the covers on the main electrical panel/sub-panel.

MPXS-30D DC Wiring

This section covers the DC wiring to/from the inverters, and from the battery bank.



WARNING: During normal operation, the terminals, busbars, and electrical components inside the MP enclosure may be energized – DO NOT TOUCH. Disconnect all power sources before removing the cover.



WARNING: Use precaution when working with the DC/battery system, even though it is a “low voltage” system significant hazards may be present, particularly if short circuits occur.



CAUTION: DO NOT connect the battery cables to the battery bank until all wiring to the inverters and inside the MP/MPX enclosures is complete, and the correct DC voltage and polarity have been verified.

Installing DC Cables from Inverters to MP (see Fig. 3-18c - MPSL-30D, Fig. 3-19c - MPSH-30D)

IMPORTANT: Coordinate the DC wiring to each inverter from each DC breaker such that the far left inverter (Master) is connected to the far left breaker (Master DC breaker), and the second inverter (Slave 1) is connected to the second DC breaker (Slave 1 breaker), and so on.

1. Route a DC positive cable (red) from each inverter into the MP enclosure.
2. Connect the end of the DC positive cable (red) to the inverter’s positive DC terminal.
3. Connect the other end of the DC positive cable (red) to a DC circuit breaker’s top terminal.
4. Route a DC negative cable (black) from each inverter into the MP enclosure.
5. Connect the end of the DC negative cable (black) to the inverter’s negative DC terminal.
6. Connect the other end of the DC negative cable (black) to the top of the DC shunt’s busbar.
7. Route an appropriately sized DC equipment ground wire from each new inverter’s DC GROUND terminal to the DC GROUND busbar in the MP enclosure.
8. Verify all DC connections are torqued from 10 to 12 ft lbf (13.6 to 16.3 N-m).
9. Once the DC connections are correctly wired and tested, coat the terminals with an approved anti-oxidizing coating.

Installing the DC Cables From the Battery Bank to the MP Enclosure (see Figure 3-18d - MPSL-30D, Figure 3-19d - MPSH-30D)

IMPORTANT: Damage may occur if DC power is connected to the MP enclosure before the Communication wiring is completed. **DO NOT** connect the DC cables from the MP enclosure to the battery bank until: 1) all DC, AC, and Comm wirings are completed, 2) the correct DC and AC overcurrent protection have been installed and, 3) the correct DC voltage and polarity have been verified.



WARNING: Ensure all AC and DC breakers are switched OFF before connecting or disconnecting the battery cables, and that all AC and DC power is disconnected from the inverter.



WARNING: Lethal currents will be present if the positive and negative cables attached to the battery bank touch each other. During the installation and wiring process, ensure the cable ends are insulated or covered to prevent touching/shorting the cables.



CAUTION: The Magnum inverter is NOT reverse polarity protected, if this happens the inverter will be damaged and will not be covered under warranty. Before making the final DC connection from the MP enclosure down to the battery bank, verify the correct battery voltage and polarity by using a voltmeter. If the positive (+) terminal of the battery is connected to the negative (–) busbar of the MP enclosure and vice versa, severe damage will result. Ensure the cables are color-coded to avoid polarity confusion.

1. Route a DC positive battery cable (red) from the battery bank thru the bottom of the MP enclosure for each inverter.
2. Connect the end of each DC positive battery cable (red) to a DC circuit breaker’s bottom battery positive connection.

3.0 Installation

3. Route a DC negative battery cable (black) from the battery bank thru the bottom of the MP enclosure for each inverter.
4. Connect the end of each DC negative battery cable (black) to the battery negative connection (DC shunt's bottom busbar).
5. Route an appropriately sized DC equipment ground wire from the ground terminal in the battery bank enclosure to the DC ground terminal in the MP enclosure.
6. Route an appropriately sized DC grounding wire (green or bare wire) from the DC GROUND busbar in the MP enclosure to the system ground (see the MP owner's manual for information on sizing and connecting the system ground wire).
7. Ensure the DC wire connections (to the inverter, DC circuit breaker, and DC shunt) are flush on the surface of the DC terminals and the hardware used to hold these connections are stacked correctly (see Figure 3-17); and then securely tighten these connections.

IMPORTANT: Only after the entire installation is complete and all connections are verified, should the DC circuit breaker be closed to provide power to the inverters.

MPXS-30D Communication Wiring

Each MPXS-30D kit includes a remote cable and a stacking cable for connecting to a router. The Magnum router comes with two CAT 5 stacking cables and two RJ11 remote cables. The MP enclosure comes with an extension cable for connecting the inverter to a Battery Temperature Sensor (BTS).

Connecting Remote Cables to Router (Figure 3-18e - MPSL-30D, Figure 3-19e - MPSH-30D)

1. Using the supplied RJ11 remote cables, route a cable from each inverter through the MPX to the attached router.
2. Connect one end of each remote cable to the Remote (blue label) port on each installed inverter.
3. Connect the other end of each remote cable to its respective comm port (P1-P6) on the router.



Info: It is recommended that the Master inverter be connected to Port 1, Slave 1 to Port 2 etc., in order to keep track of which inverter is displayed on each port.

Connecting Stacking Cables to Router (Figure 3-18e - MPSL-30D, Figure 3-19e - MPSH-30D)

1. Using the supplied stacking (CAT 5) cables, route a cable from each inverter through the MPX to the attached router.
2. Connect one end of each stacking cable to the Stack Port (red label) on each installed inverter.
3. Connect the other end of each stacking cable to its respective CAT 5 port on the router (MA, SL1, SL2, and SL3 ports for the appropriate number of installed inverters).



Info: At least one CAT 5 cable **must** be plugged into the router's MA port in order for the router to operate any inverters.

Battery Temperature Sensors (BTS) (Figures 3-18e - MPSL-30D, Figure 3-19e - MPSH-30D)

The Battery Temperature Sensor provides the inverter with precise battery temperature information that enables the batteries to be correctly charged under extreme temperature changes. If the BTS is not installed and the batteries are subjected to large temperature changes, battery life may be shortened.

1. Using the supplied extension cable, route the cable from the Master inverter through the MPX and the MP enclosure to the BTS.



Info: When the inverters are installed in parallel, the BTS **must** be connected to the Master inverter.

2. Connect one end the extension cable to the Battery Temp Sensor port (yellow label) on the Master inverter.
3. Connect the other end of the extension cable to the RJ-11 connector on the BTS.

Connecting the DC Cables from the MP Enclosure to the Battery Bank

Once all the wiring is completed, connect the DC cables from the MP enclosure to the battery bank.

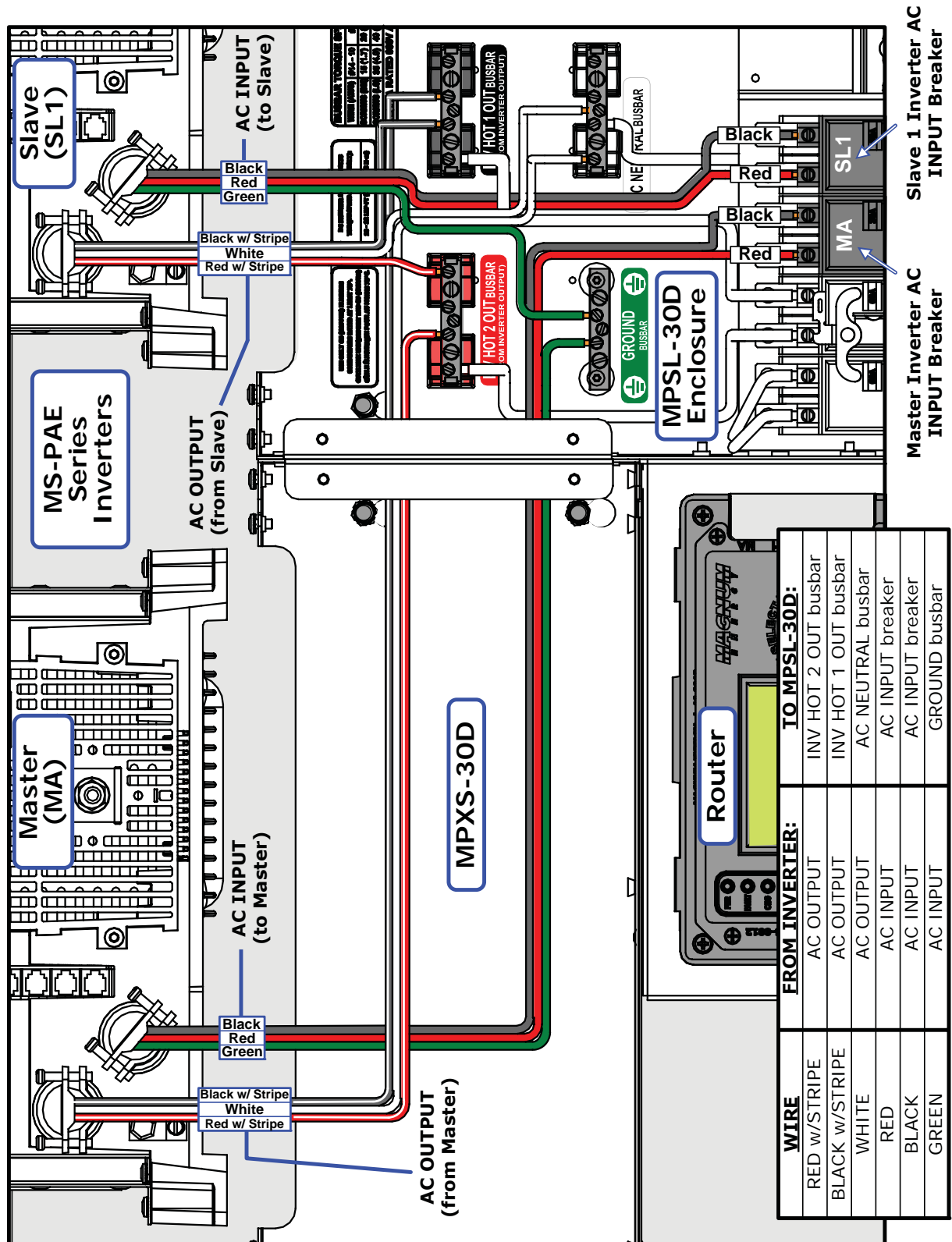

Figure 3-18a, MPXS-30D / MPLS-30D Inverter AC Wiring

3.0 Installation

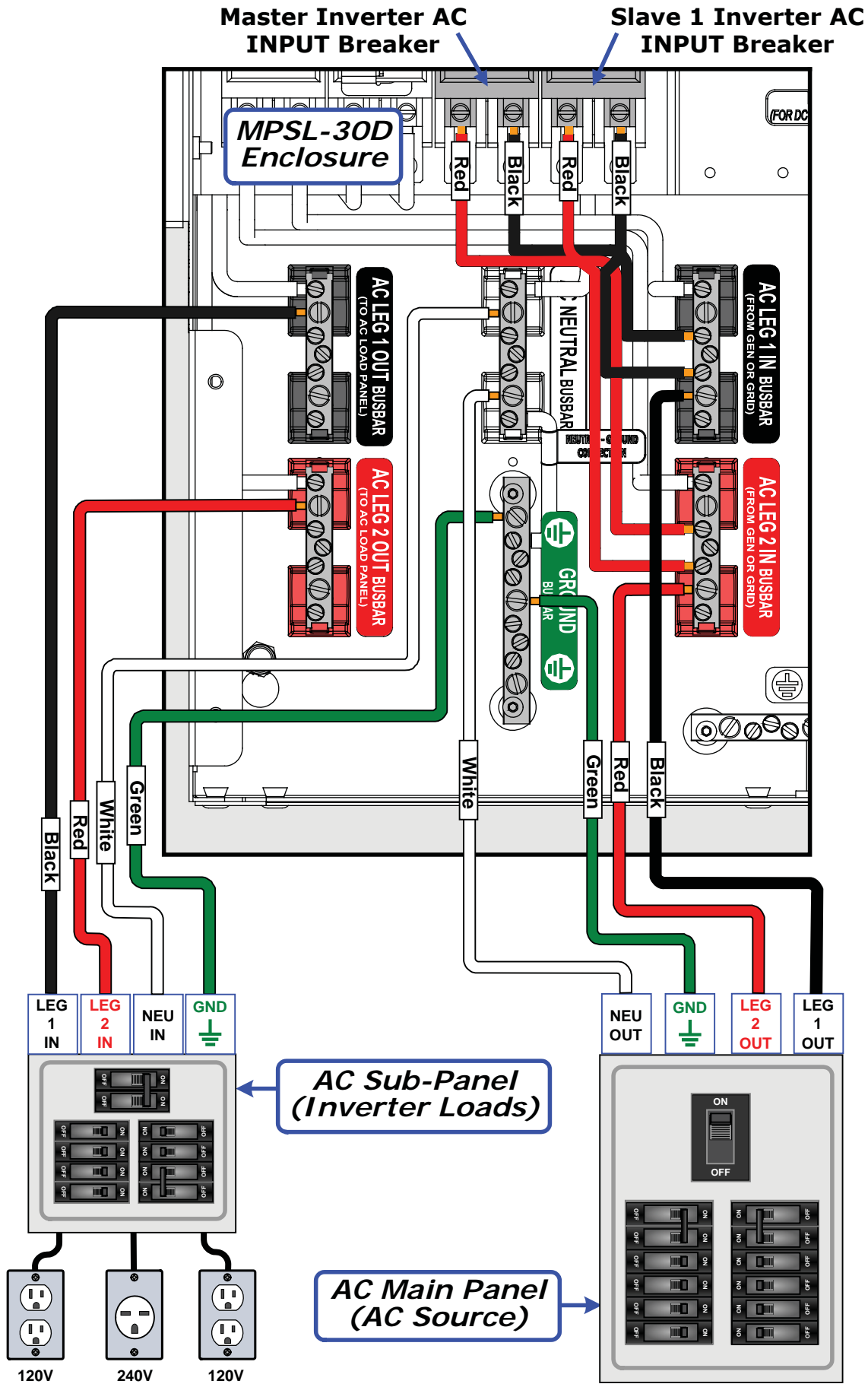

Figure 3-18b, MPXS-30D / MPLS-30D External AC Wiring

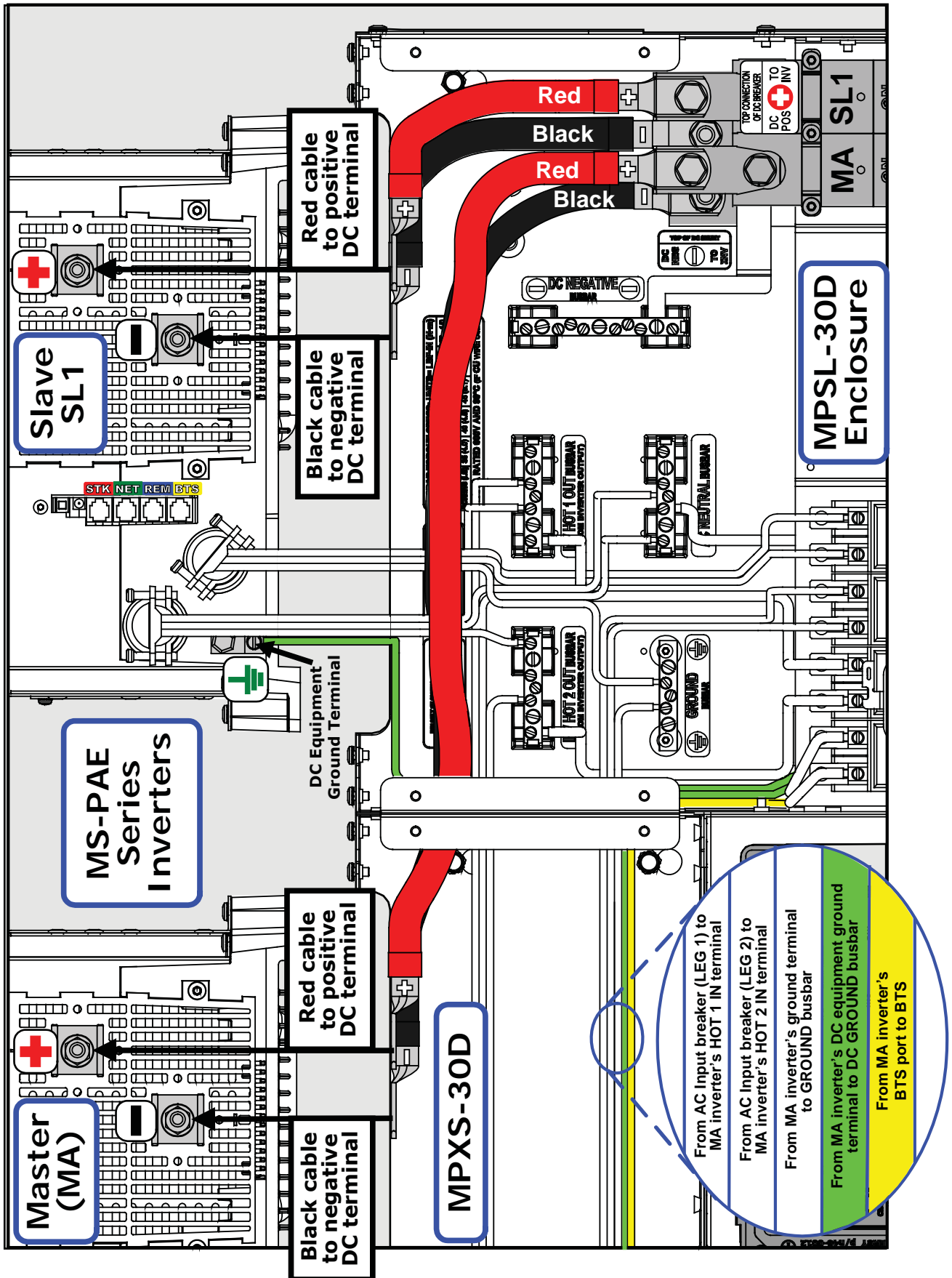

Figure 3-18c, MPXS-30D / MPXL-30D Inverter DC Wiring

3.0 Installation

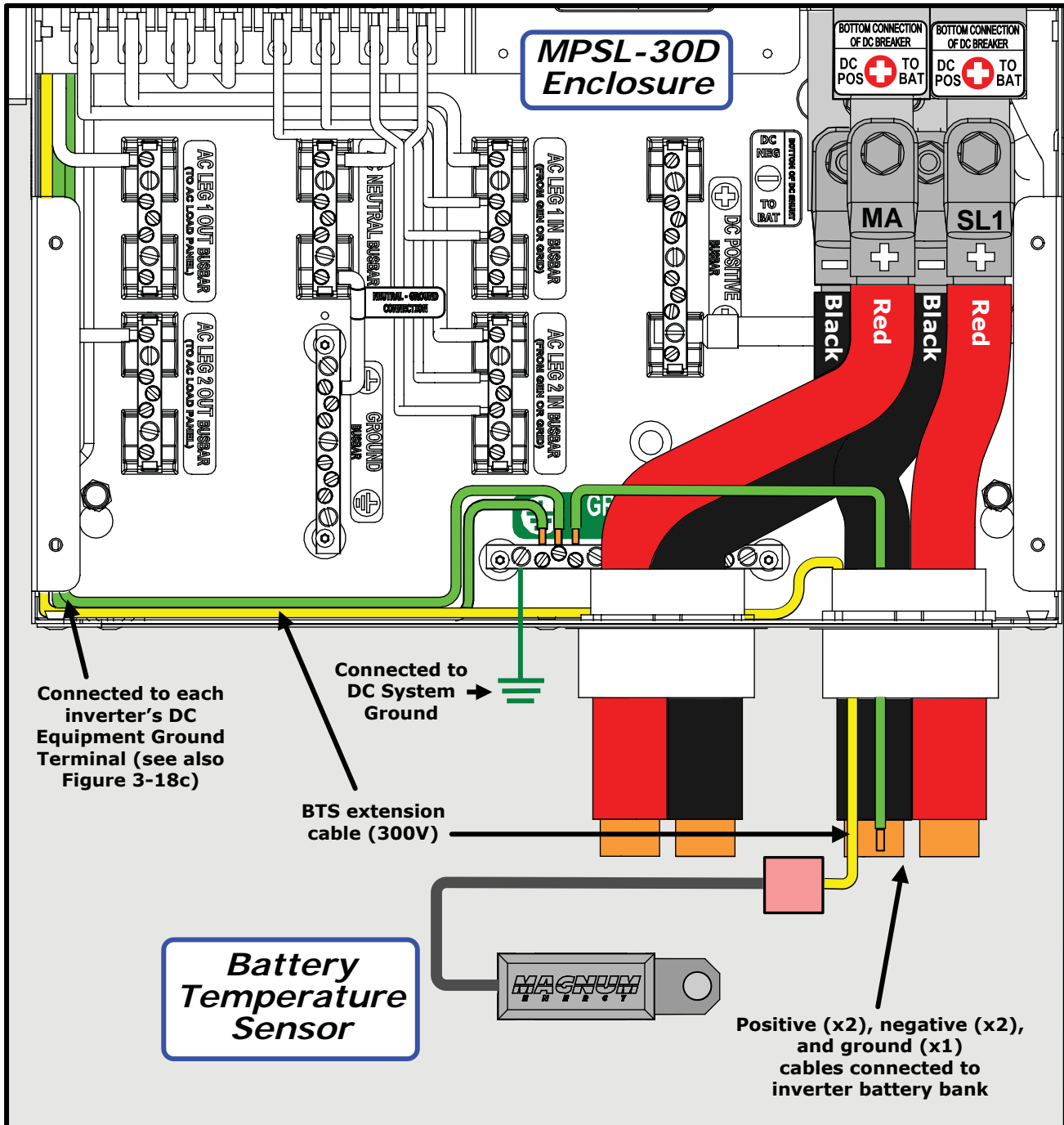

Figure 3-18d, MPXS-30D / MPSL-30D Battery Bank DC Wiring

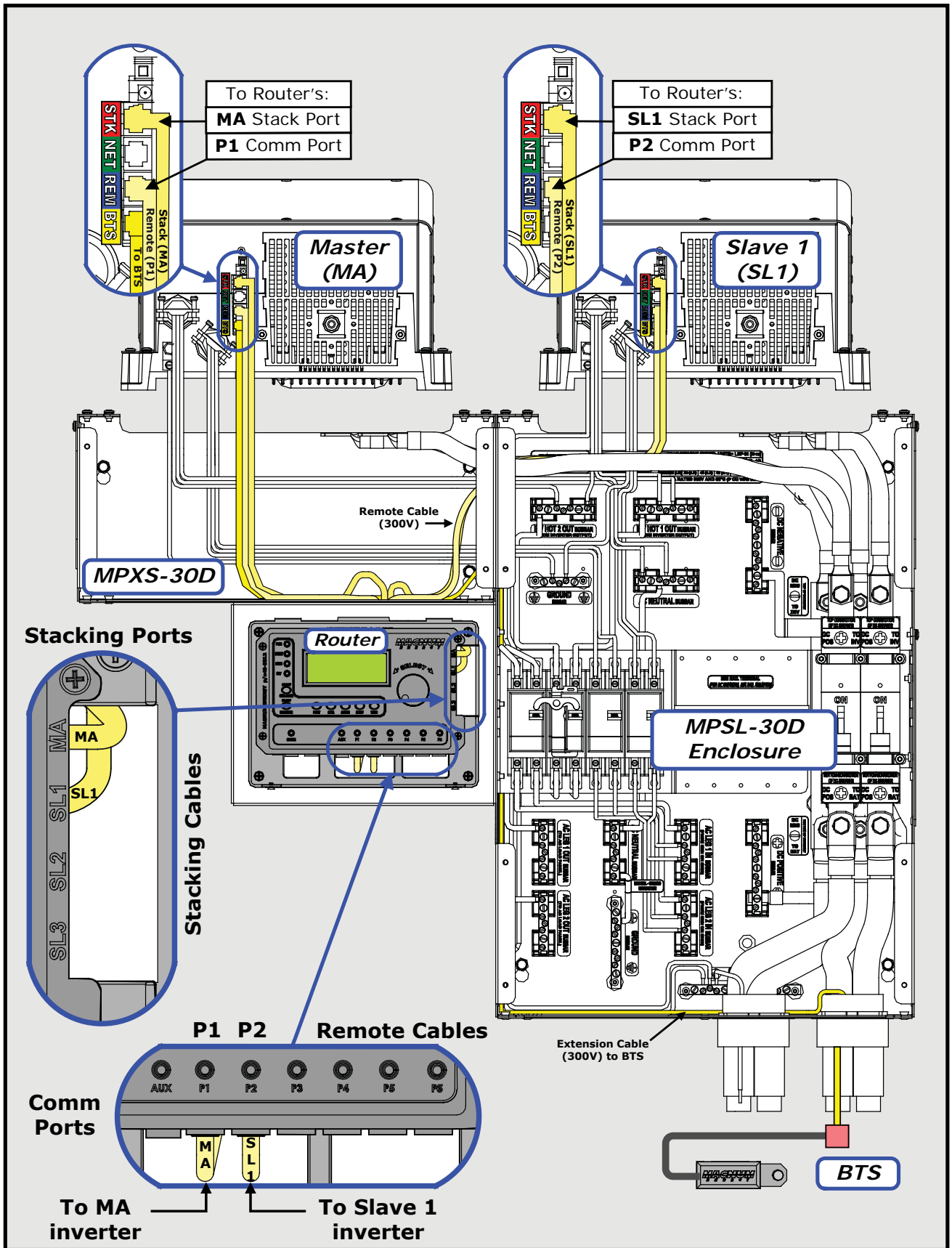

Figure 3-18e, MPXS-30D / MPSL-30D Communication Wiring

3.0 Installation

| WIRE | FROM INVERTER: | TO MPXH-30D: |
|----------------|----------------|----------------------|
| RED w/STRIPE | AC OUTPUT | INV HOT 2 OUT busbar |
| BLACK w/STRIPE | AC OUTPUT | INV HOT 1 OUT busbar |
| WHITE | AC OUTPUT | AC NEUTRAL busbar |
| RED | AC INPUT | AC INPUT breaker |
| BLACK | AC INPUT | AC INPUT breaker |
| GREEN | AC INPUT | GROUND busbar |

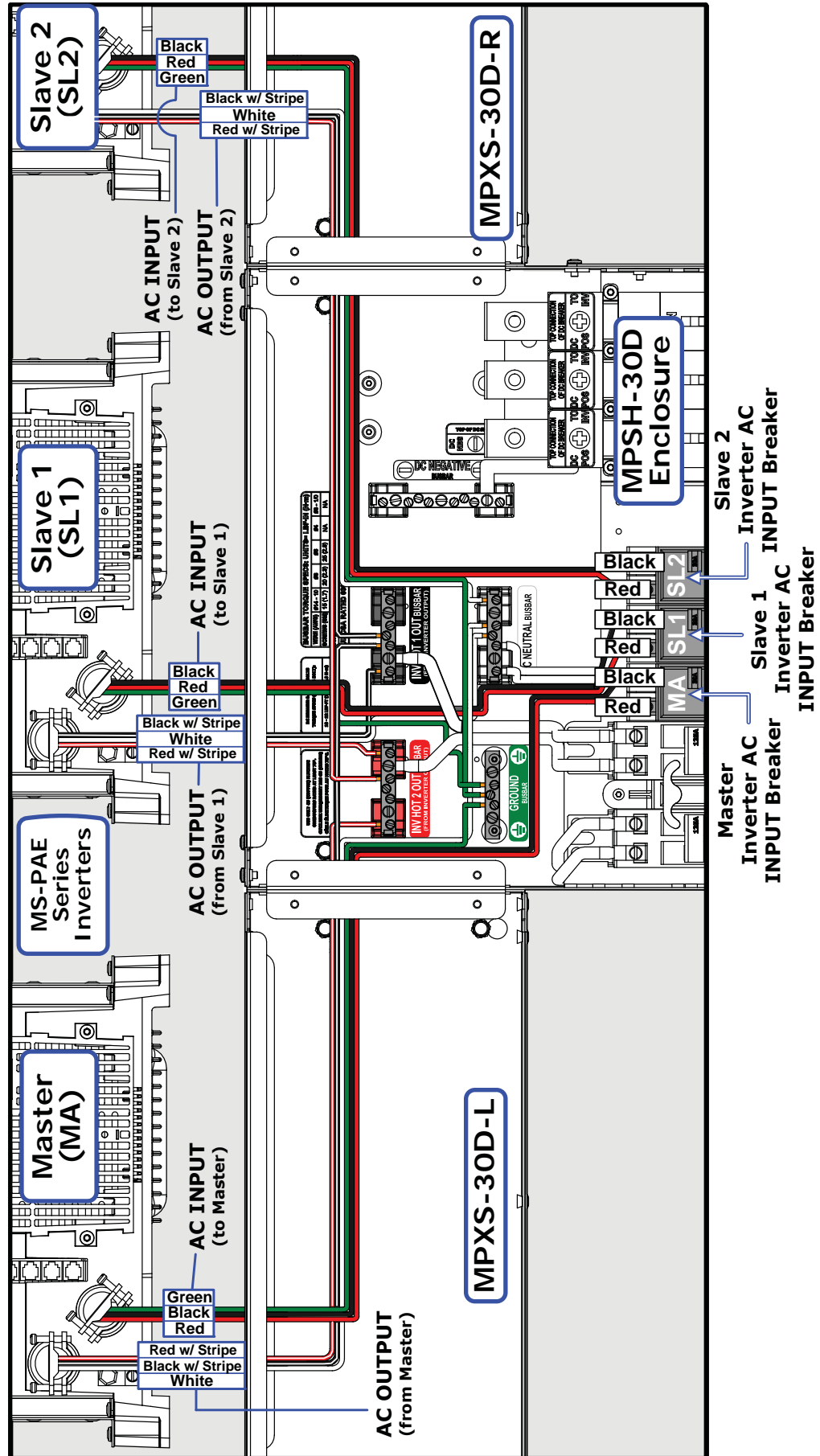

Figure 3-19a, MPXS-30D / MPXH-30D Inverter AC Wiring

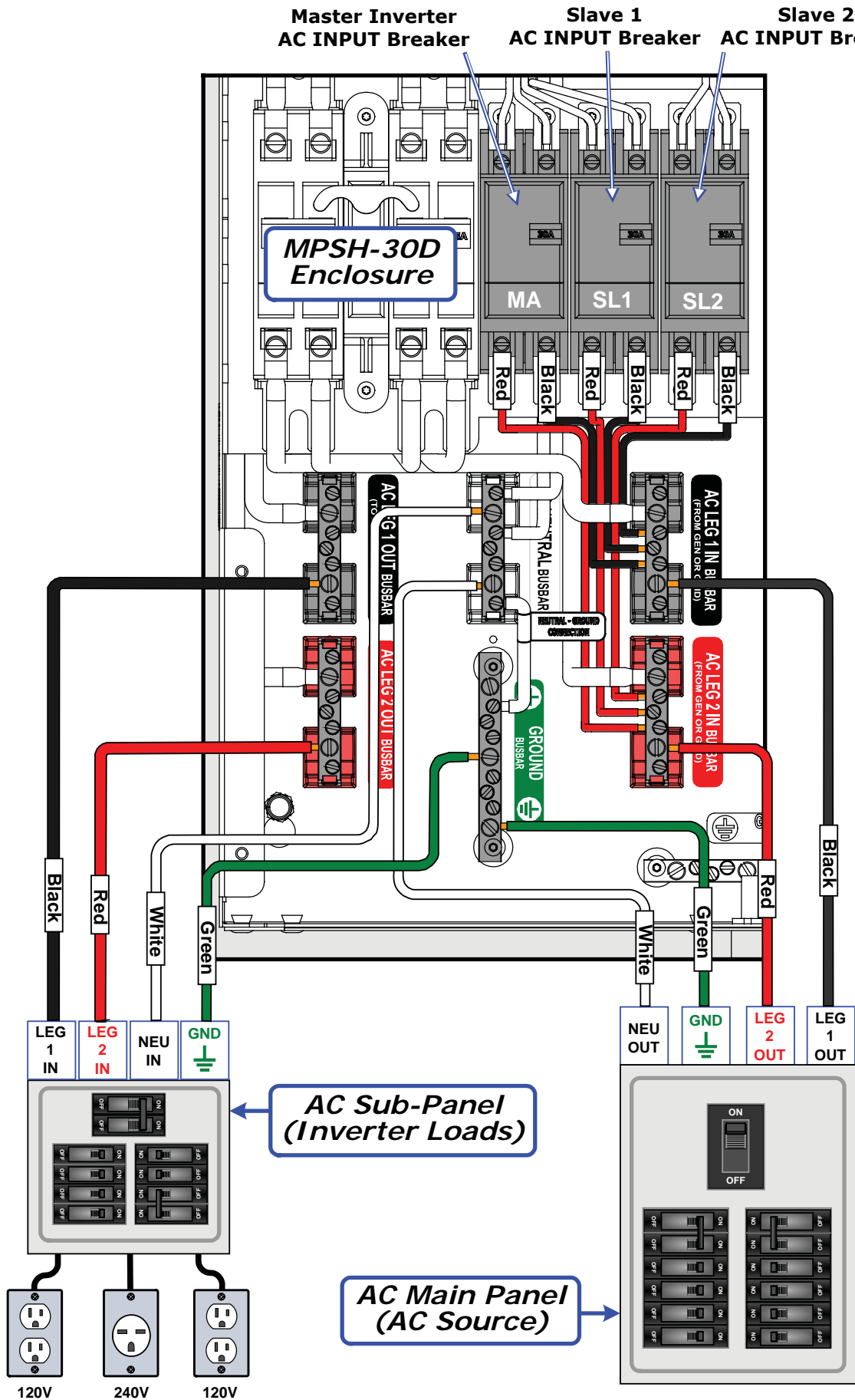

Figure 3-19b, MPXS-30D / MESH-30D External AC Wiring

3.0 Installation

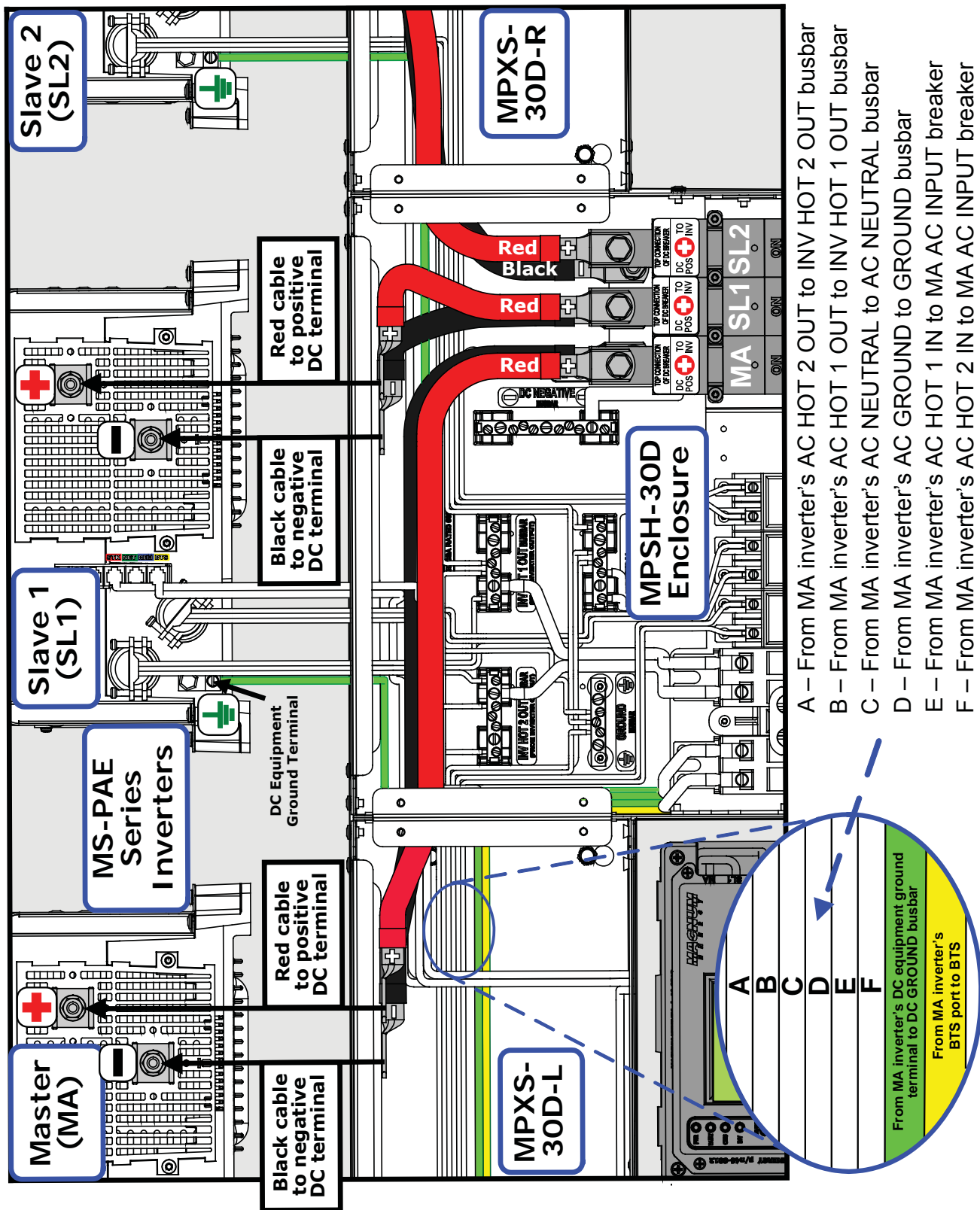

Figure 3-19c, MPXS-30D / MPXH-30D Inverter DC Wiring

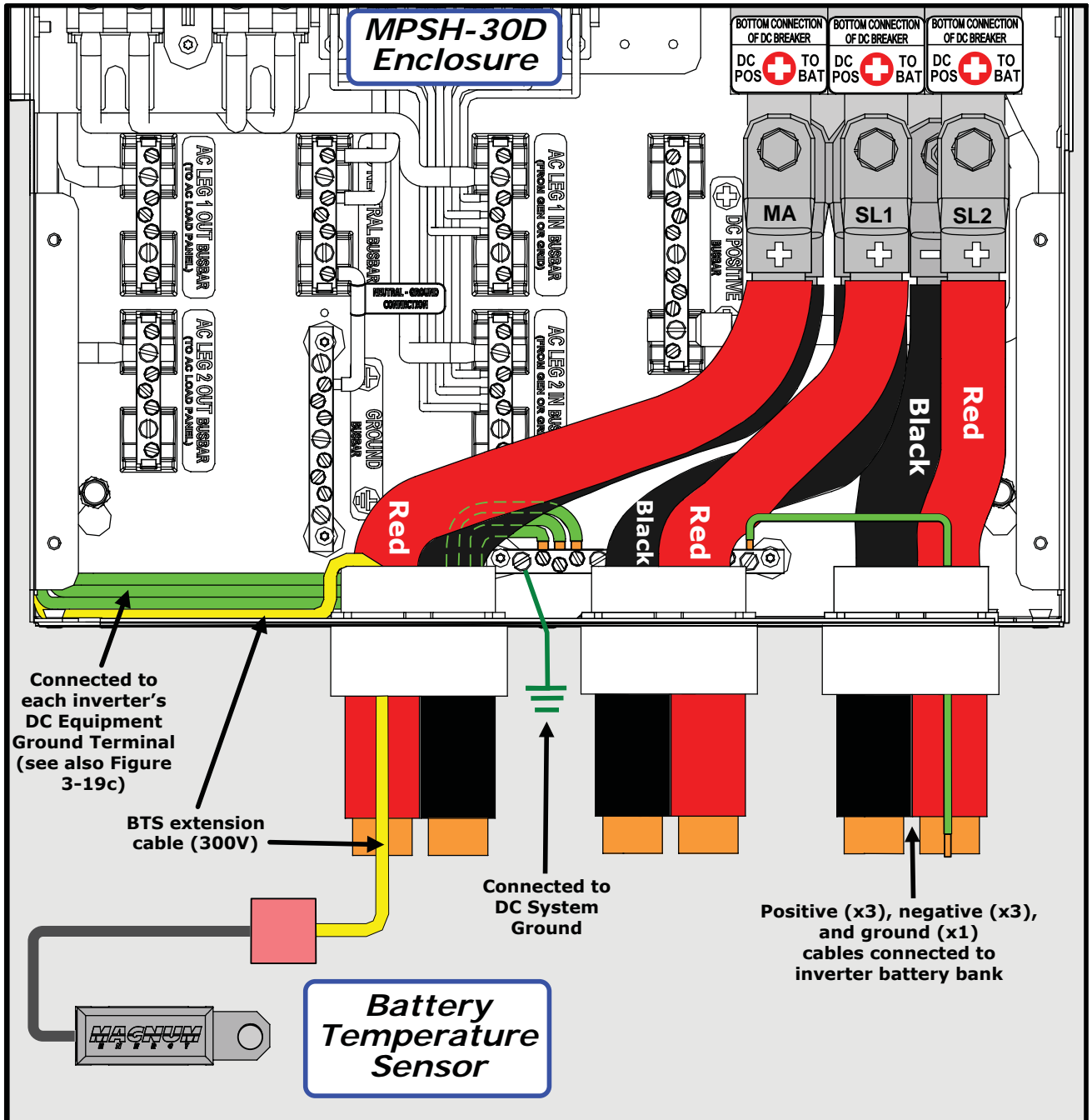

Figure 3-19d, MPXS-30D / MESH-30D Battery Bank DC Wiring

3.0 Installation

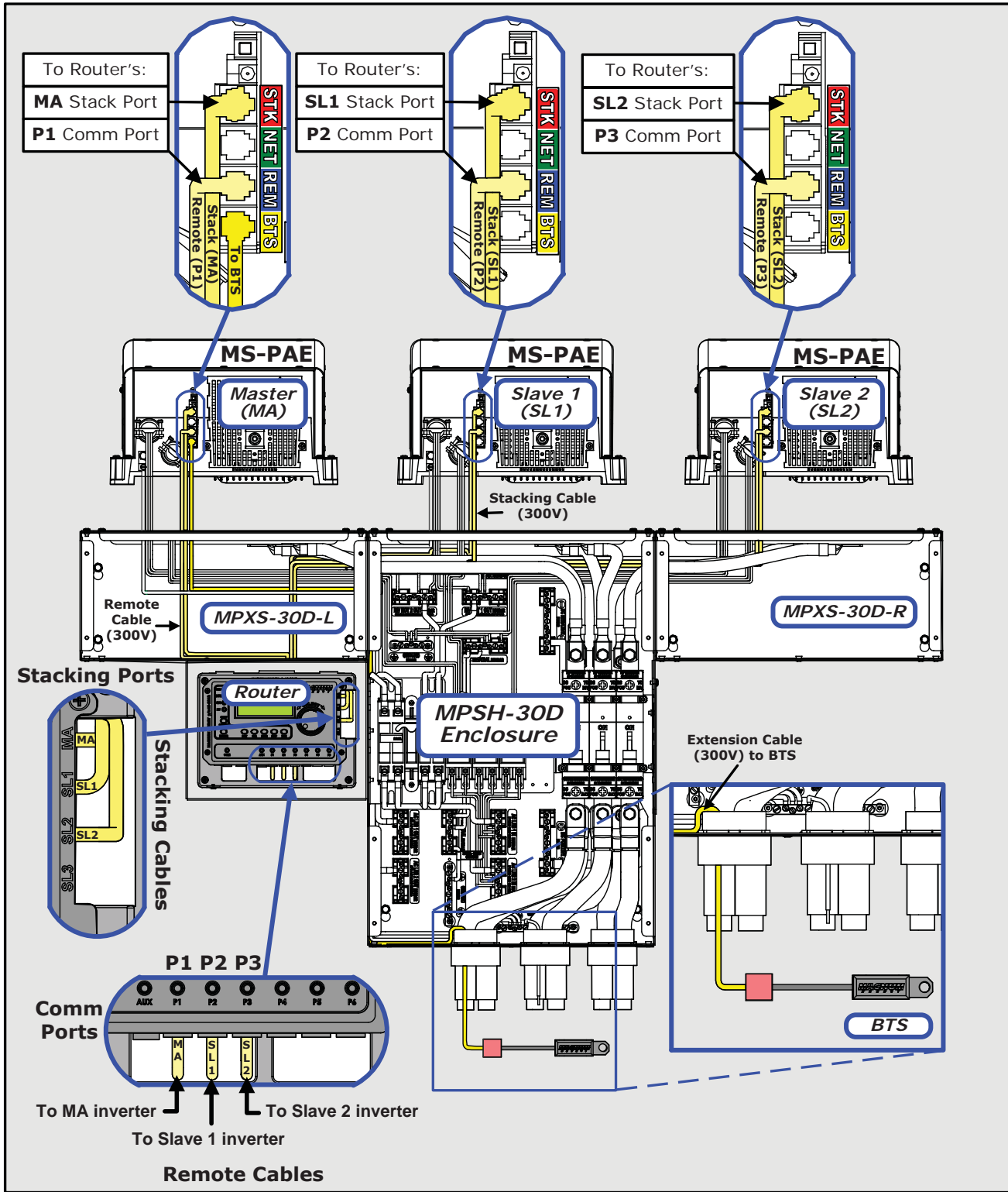

Figure 3-19e, MPXS-30D / MPSH-30D Communication Wiring

3.2.3 Wiring the MPXS-60S

The following steps are basic guidelines for installing and connecting the AC, DC, and communication cables for the MPXS-60S.



WARNING: To prevent electrical shock, make sure all AC power (inverter, generator, or utility) is off before making any AC connections inside the MP enclosure.

MPXS-60S AC Wiring

This section provides information on the AC wiring to/from the MS4024 inverters, and to/from the main panel and sub-panel. The MPXS-60S kit includes #6 AWG strand B wires for wiring to the AC terminals in the MP panel. The HOT 1 and HOT 2 wires into/out of the inverter are longer than needed. This allows you to cut and use the two excess wire lengths (one black and one red, or one black w/ stripe and one red w/ stripe) for routing AC wires from the bottom of the AC breakers to the MP's busbar terminals. See Table 2-1 for AC wire size, color, length, and routing location.

Inverter AC Input Wiring (see Figures 3-20a and 3-21a)

LEG 2 AC Input Wiring

1. Route and attach a red wire from the top terminal of the MP enclosure's AC input breaker (B1) to the HOT 2/LEG 2 inverter's AC HOT 1 IN and AC HOT 2 IN terminals.
2. Route and attach a white wire from the MP enclosure's AC NEUTRAL busbar to the HOT 2/LEG 2 inverter's AC NEUTRAL terminal.
3. Route and attach a green wire from the MP enclosure's GROUND busbar to the HOT 2/LEG 2 inverter's AC GROUND terminal.

LEG 1 AC Input Wiring

NOTE: The LEG 1 AC input wiring is shown in the MP enclosure owner's manual.

Inverter AC Output Wiring (see Figures 3-20a and 3-21a)

LEG 2 AC Output Wiring

1. Route and attach a red w/white stripe wire from the MP enclosure's INV HOT 2 OUT busbar to HOT 2/LEG 2 inverter's AC HOT 2 OUT and AC HOT 1 OUT terminals.
2. Route and attach a white wire w/black stripe from the MP enclosure's AC NEUTRAL busbar to HOT 2/LEG 2 inverter's AC NEUTRAL terminal.

LEG 1 AC Output Wiring

NOTE: The LEG 1 AC output wiring is shown in the MP enclosure owner's manual.

NOTE: For the full 60 amp AC pass-thru on MS4024 model inverters, the inverter's HOT 1 and HOT 2 terminals must be wired together. Each terminal (separately) is only rated for 30 amp AC. See Figure 4-1 in the MP manual (PN: 64-0028), or refer to your MS Series owner's manual for more info on AC wiring.

3.0 Installation

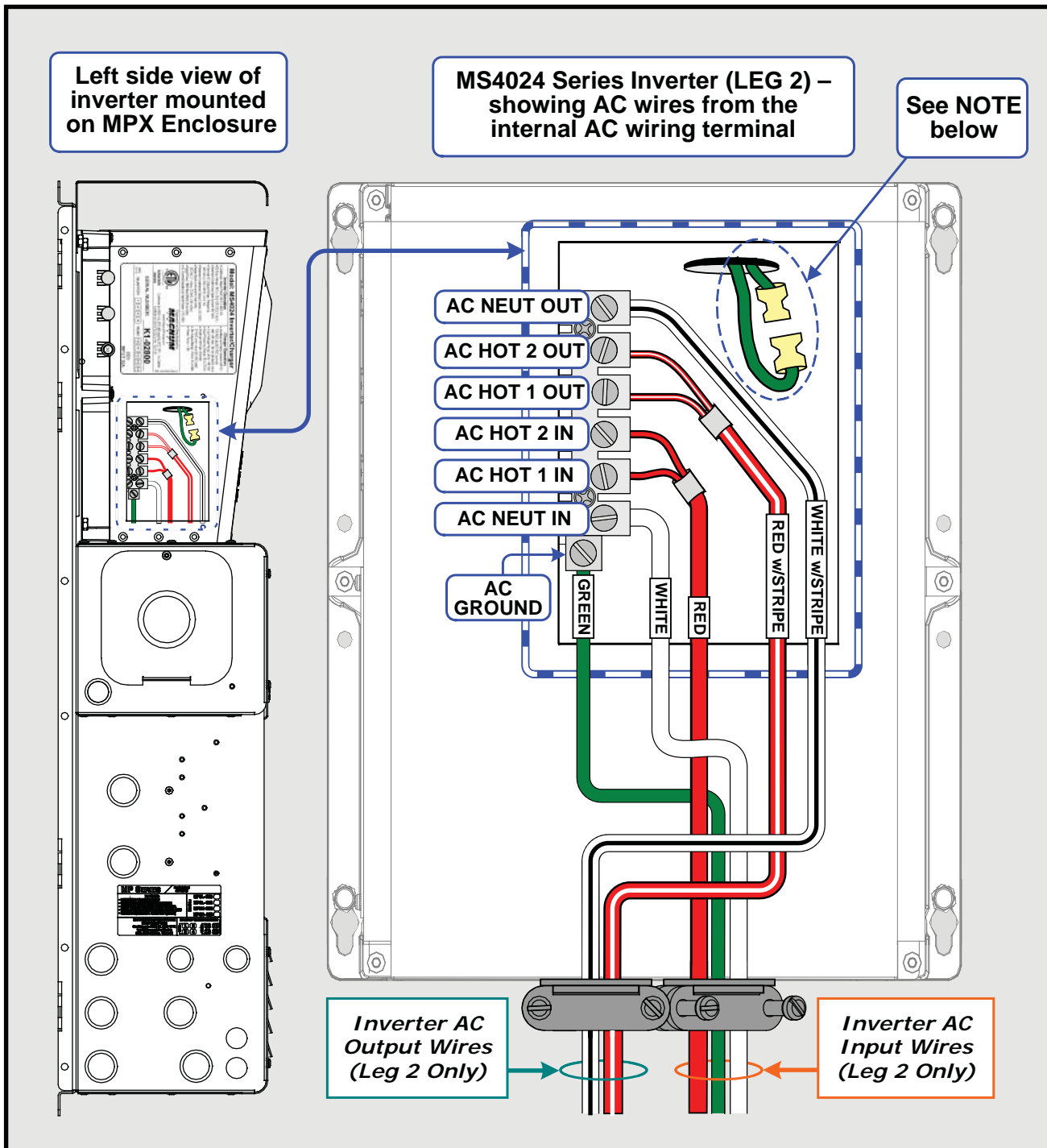

Figure 3-20a, Inverter AC Input and Output Wiring Diagram



Info: When wiring the MS4024 (or any other MS Series inverter), both the inverter input and output neutral wires must be connected to a AC NEUTRAL busbar inside the MP enclosure. This is because — depending on the inverter’s operating mode — the inverter’s input and output neutral terminals may not be connected together (i.e., inverter’s neutrals are not connected when “inverting”, and are combined when “charging”).

NOTE: Because a neutral to ground connection is also made in the MP enclosure, the neutral to ground connection inside the MS4024 must be disconnected. Refer to your MS4024 owner’s manual for information on how this is done.

Bottom AC Breaker Wiring (see Figures 3-20b & 3-21b)



Info: Before proceeding any further, disconnect the black AC LEG 1 IN cable from the bottom left terminal of the AC breaker and reconnect to the bottom right terminal as shown in Figure 3-20b.

- Route and attach a red wire from the bottom terminal of the AC input breaker (B1) to the MP enclosure's AC LEG 2 IN busbar.

IMPORTANT: Prior to installing the MPXS-60S's external AC wiring, disconnect and then reconnect the AC LEG 1 IN black wire from the left breaker (B1) to the newly installed right breaker (B2), as shown in Figure 3-20b. This ensures that the phase relationship (LEG 1/black on right to LEG 2/red on left) between the AC input source and the output are correct.

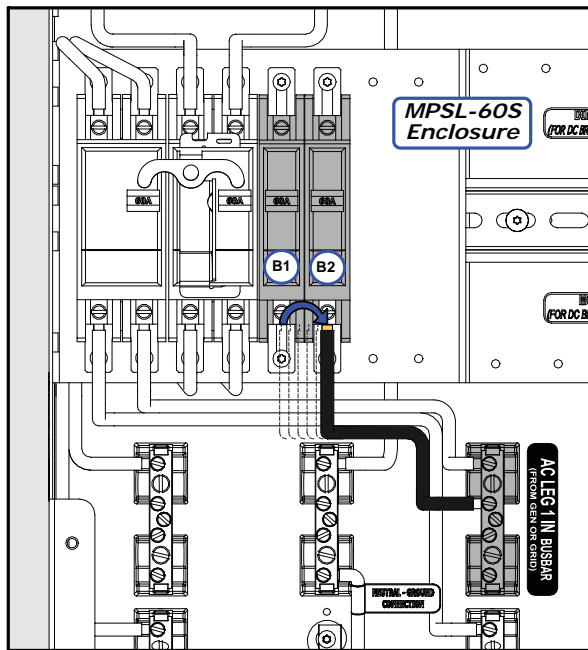

NOTE: The AC LEG 1 IN wire is moved from the **B1** position to the **B2** position to ensure correct input/output phase relationship.

Figure 3-20b, MPXS-60S / MPSL-60S AC Breaker Input Wire Transition

External AC Main Panel Wiring (see Figure 3-21b)

- Route and attach a black wire from the MP enclosure's AC LEG 1 IN busbar to the main AC electrical panel.
- Route and attach a red wire from the MP enclosure's AC LEG 2 IN busbar to the main AC electrical panel.
- Route and attach a green wire from the MP enclosure's GROUND busbar to the main AC electrical panel's Ground busbar.
- Route and attach a white wire from the MP enclosure's AC NEUTRAL busbar to the main AC electrical panel's Neutral busbar.

External AC Sub-Panel Wiring (see Figure 3-21b)

- Route and attach a black wire from the MP enclosure's AC LEG 1 OUT busbar to the AC electrical sub-panel.
- Route and attach a red wire from the MP enclosure's AC LEG 2 OUT busbar to the AC electrical sub-panel.
- Route and attach a green wire from the MP enclosure's GROUND busbar to the AC electrical sub-panel's Ground busbar.
- Route and attach a white wire from the MP enclosure's AC NEUTRAL busbar to the AC electrical sub-panel's Neutral busbar.

AC Wiring Inspection

After verifying all AC connections are correct, and all AC terminal screws are torqued correctly, replace the covers on the main electrical panel/sub-panel.

3.0 Installation

MPXS-60S DC Wiring

This section covers the DC wiring to/from the inverters, and from the battery bank.



WARNING: During normal operation, the terminals, busbars, and electrical components inside the MP enclosure may be energized – DO NOT TOUCH.



WARNING: Disconnect all power sources before removing the cover. Even though DC voltage is “low voltage”, significant hazards may be present, particularly from short circuits of the battery system.



CAUTION: DO NOT connect the battery cables to the battery bank until all wiring to the inverters and inside the MP/MPX enclosure is complete and the correct DC voltage and polarity have been verified.

Installing the DC Cables From the Inverters to the MP (see Figure 3-21c)

IMPORTANT: Coordinate the DC wiring to each inverter from each DC breaker such that the far left inverter is connected to the far left breaker (HOT 2/LEG 2 DC breaker), and the second inverter is connected to the second DC breaker (HOT 1/LEG 1 breaker), and so on.

1. Route a DC positive cable (red) from each inverter into the MP enclosure.
2. Connect the end of the DC positive cable (red) to the inverter’s positive DC terminal.
3. Connect the other end of the DC positive cable (red) to a DC circuit breaker’s top terminal.
4. Route a DC negative cable (black) from each inverter into the MP enclosure.
5. Connect the end of the DC negative cable (black) to the inverter’s negative DC terminal.
6. Connect the other end of the DC negative cable (black) to the top of the DC shunt’s busbar.
7. Route an appropriately sized DC equipment ground wire from each new inverter’s DC GROUND terminal to the DC GROUND busbar in the MP enclosure.
8. Verify all DC connections are torqued from 10 to 12 ft lbf (13.6 to 16.3 N-m).
9. Once the DC connections are correctly wired and tested, coat the terminals with an approved anti-oxidizing coating.

Installing the DC Cables From the Battery Bank to the MP Enclosure (see Figure 3-21d)

IMPORTANT: Damage may occur if DC power is connected to the MP enclosure before the Communication wiring is completed. **DO NOT** connect the DC cables from the MP enclosure to the battery bank until: 1) all DC, AC, and Comm wirings are completed, 2) the correct DC and AC overcurrent protection have been installed and, 3) the correct DC voltage and polarity have been verified.



WARNING: Ensure all AC and DC breakers are switched OFF before connecting or disconnecting the battery cables, and that all AC and DC power is disconnected from the inverter.



WARNING: Lethal currents will be present if the positive and negative cables attached to the battery bank touch each other. During the installation and wiring process, ensure the cable ends are insulated or covered to prevent touching/shorting the cables.



CAUTION: The Magnum inverter is NOT reverse polarity protected, if this happens the inverter will be damaged and will not be covered under warranty. Before making the final DC connection from the MP enclosure down to the battery bank, verify the correct battery voltage and polarity by using a voltmeter. If the positive (+) terminal of the battery is connected to the negative (–) busbar of the MP enclosure and vice versa, severe damage will result. Ensure the cables are color-coded to avoid polarity confusion.

1. Route a DC positive battery cable (red) from the battery bank through the bottom of the MP enclosure for each inverter.
2. Connect the end of the DC positive battery cable (red) to the DC circuit breaker’s bottom battery positive connection.

3. Route a DC negative battery cable (black) from the battery bank thru the bottom of the MP enclosure for each inverter.
4. Connect the end of each DC negative battery cable (black) to the battery negative connection (DC shunt's bottom busbar).
5. Route an appropriately sized DC equipment ground wire from the ground terminal in the battery bank enclosure to the DC ground terminal in the MP enclosure.
6. Route an appropriately sized DC grounding wire (green or bare wire) from the DC GROUND busbar in the MP enclosure to the system ground (see the MP owner's manual for information on sizing and connecting the system ground wire).
7. Ensure the DC wire connections (to the inverter, DC circuit breaker, and DC shunt) are flush on the surface of the DC terminals and the hardware used to hold these connections are stacked correctly (see Figure 3-17); and then securely tighten these connections.

IMPORTANT: Only after the entire installation is complete and all connections are verified, should the DC circuit breaker be closed to provide power to the inverters.

MPXS-60S Communication Wiring

Each MPXS-60S kit includes a remote cable and a stacking cable. The MP enclosure comes with an extension cable for connecting the inverter to a Battery Temperature Sensor (BTS).

Connecting Remote Cables to Remotes (see Figure 3-21e)

1. Using the supplied RJ11 remote cables, route a cable from each inverter to each remote control (or router).
2. Connect one end of each remote cable to the Remote port (blue label) on each installed inverter.
3. Connect the other end of each remote cable to a separate remote control.

Connecting Inverters Using Series Stacking Cable (see Figure 3-21e)

1. Using the supplied stacking cable, route the cable from the HOT 2/LEG 2 inverter's Stack port (red label) through the MPX and MP enclosure to the HOT 1/LEG 1 inverter's Stack port.
2. Connect the two ends of the series stacking cable to the Stack port of the two installed inverters.

Battery Temperature Sensors (see Figures 3-21e)

The Battery Temperature Sensor provides the inverter with precise battery temperature information that enables the batteries to be correctly charged under extreme temperature changes. If the BTS is not installed and batteries are subjected to large temperature changes, battery life may be shortened.

1. Using the supplied extension cables, route a cable from the each inverter through the MP enclosure to a BTS.



Info: When the inverters are installed in a series, **each** inverter should have a BTS connected to its Battery Temp Sensor port.

2. Connect one end of each extension cable to the Battery Temp Sensor port (yellow label) on each inverter.
3. Connect the other end of each extension cable to the RJ-11 connector on a separate BTS.

Connecting the DC Cables from the MP Enclosure to the Battery Bank

Once all the wiring (AC, DC, and Comm) is completed, connect the DC cables from the MP enclosure to the battery bank.

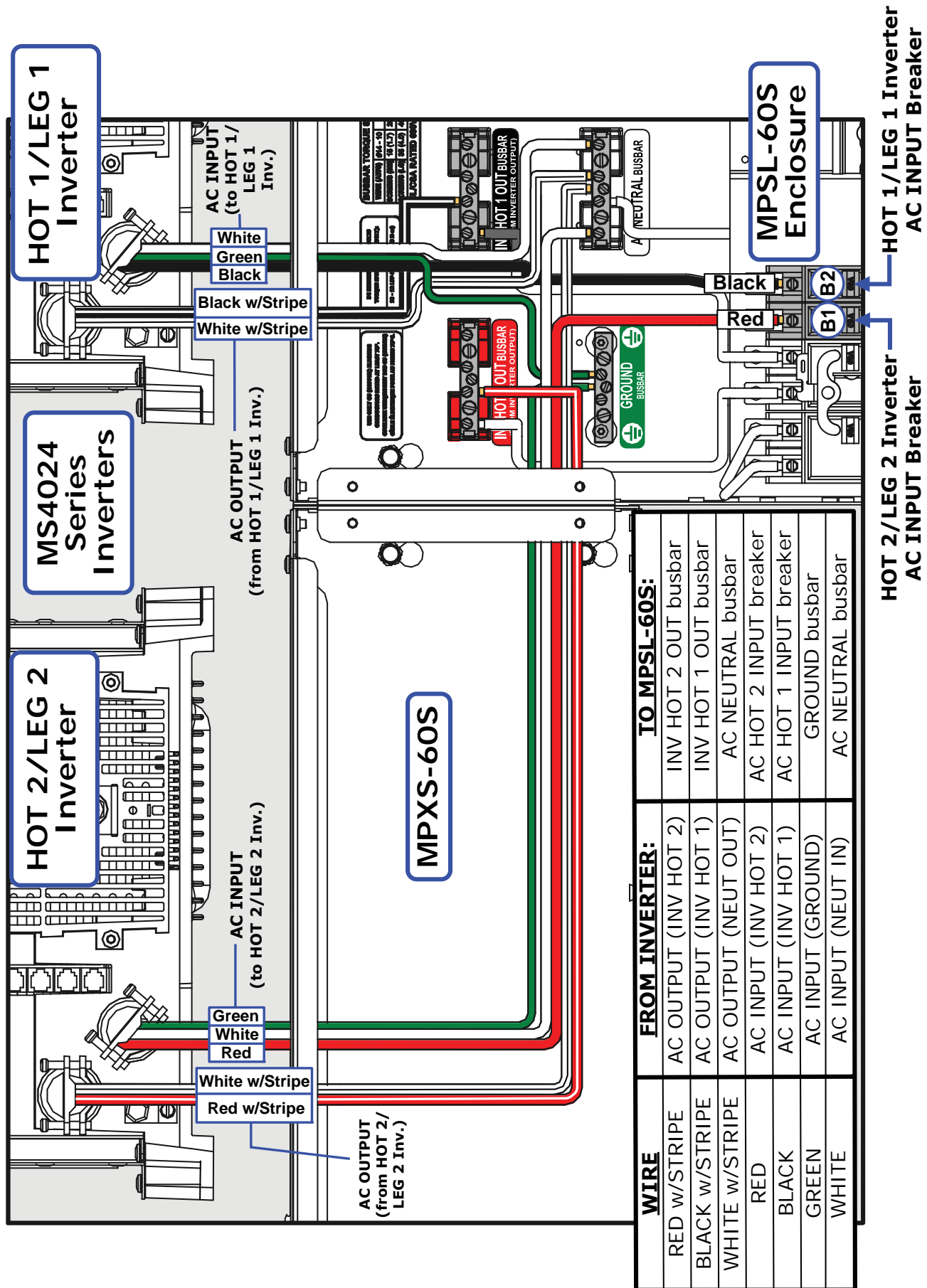

Figure 3-21a, MPXS-60S / MPSL-60S Inverter AC Wiring

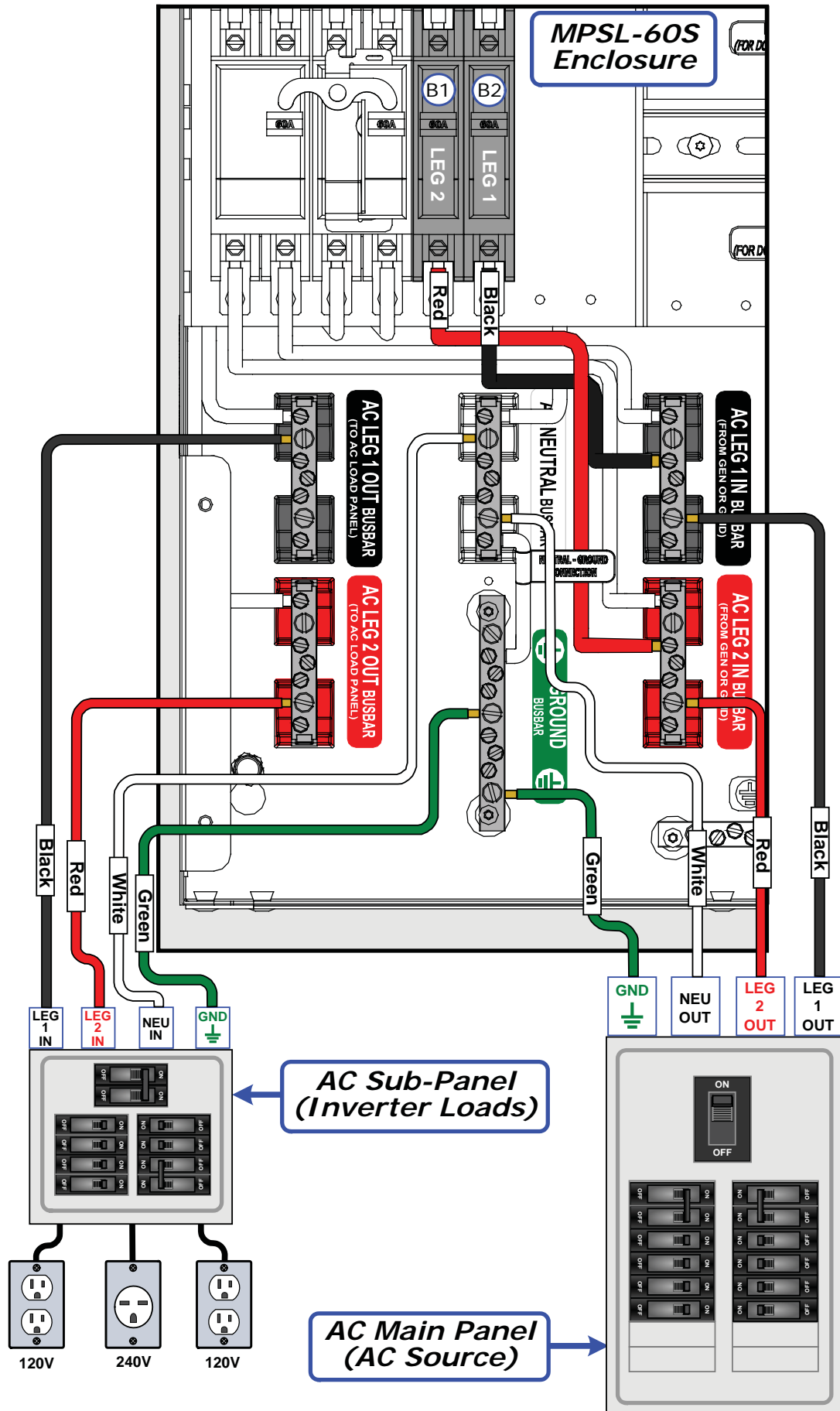

Figure 3-21b, MPXS-60S / MPXL-60S External AC Wiring

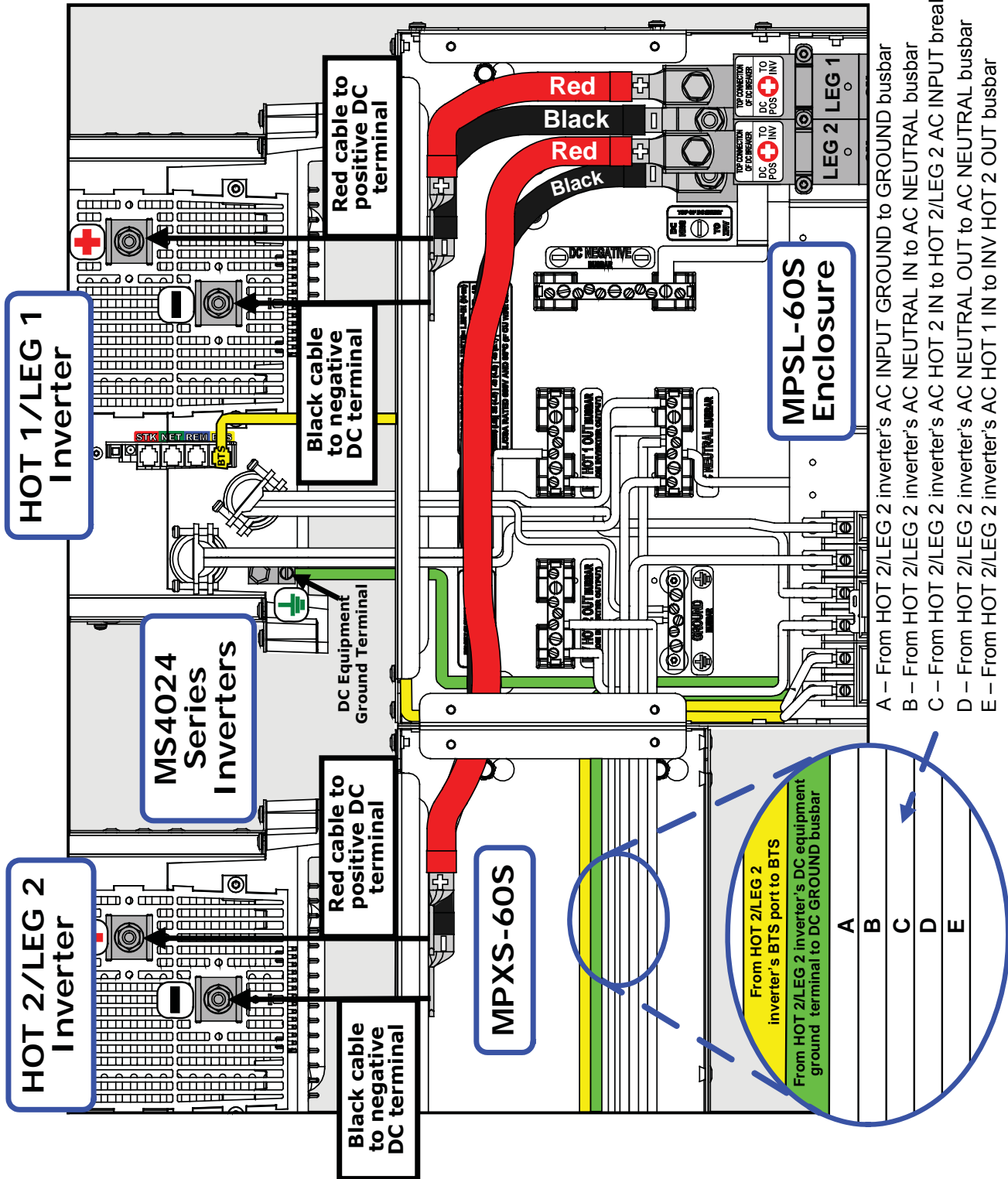

Figure 3-21c, MPXS-60S / MPSL-60S Inverter DC Wiring

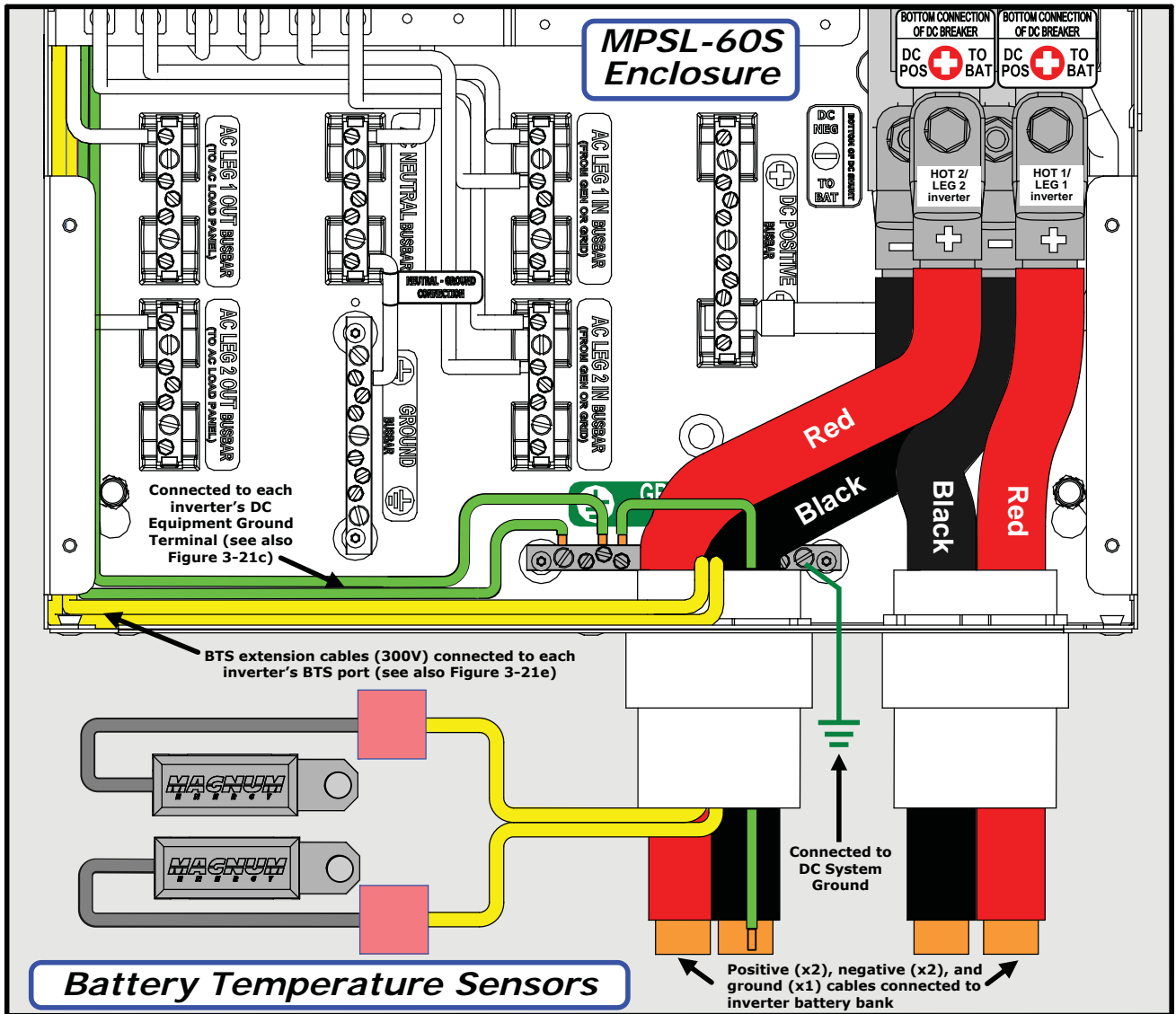

Figure 3-21d, MPXS-60S / MPSL-60S Battery Bank DC Wiring

3.0 Installation

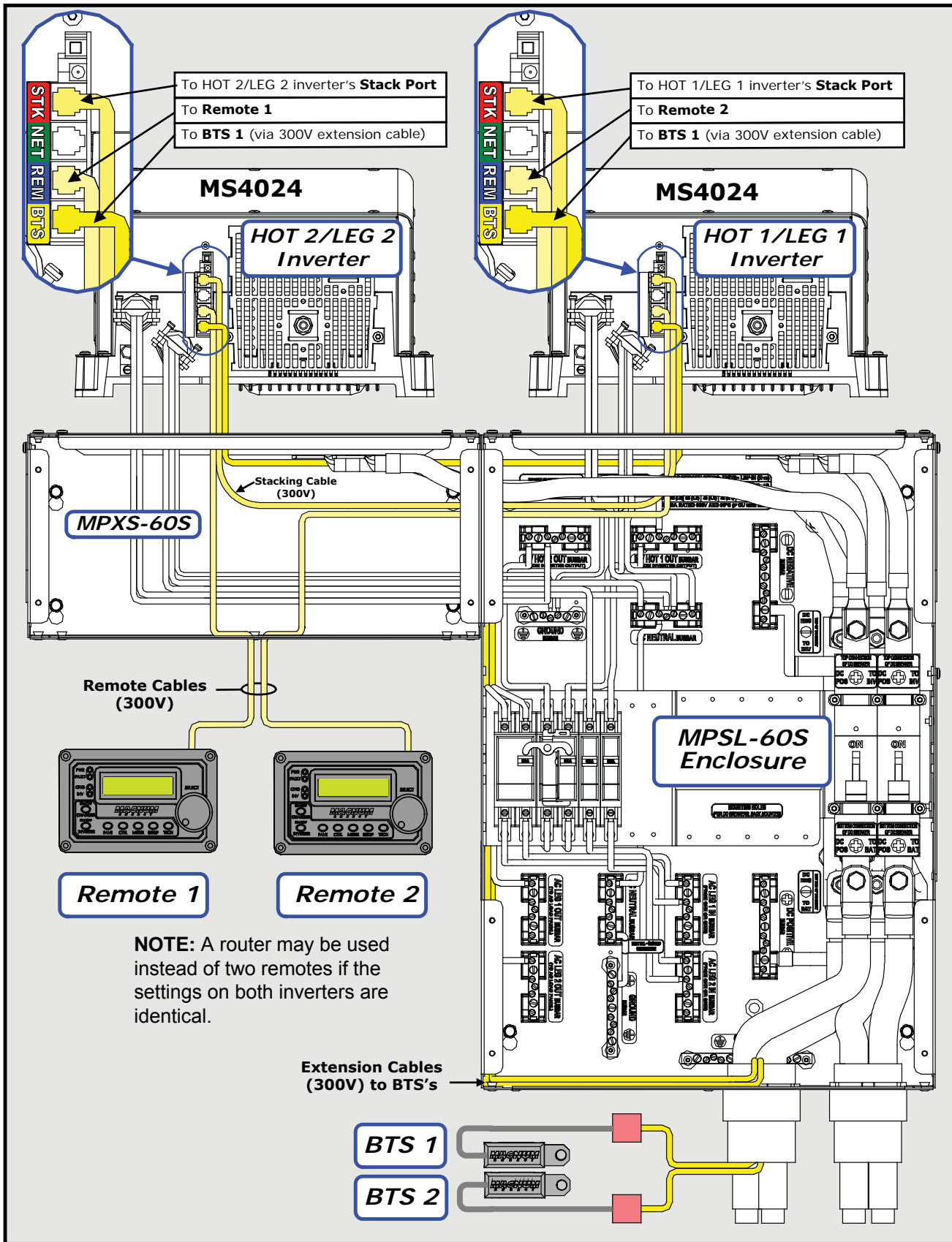

Figure 3-21e, MPXS-60S / MPXL-60S Communication Wiring

3.2.4 Wiring the MPXD-30D

The following steps are basic guidelines for installing and connecting the AC, DC, and communication wiring for the MPXD-30D.



WARNING: To prevent electrical shock, make sure all AC power (inverter, generator, or utility) is off before making any AC connections inside the MP enclosure.

MPXD-30D AC Wiring

This section provides information on the AC wiring to/from the MS-PAE Series inverters, and to/from the main and sub-panels.

Inverter AC Input Wiring (see Figures 3-22a.1 and 3-22a.2)

1. Route and attach a black wire from the top right terminal of the new AC input breakers (left MP enclosure) to each inverter's AC HOT 1 IN terminal.
2. Route and attach a red wire from the top left terminal of the new AC input breakers to each inverter's AC HOT 2 IN terminal.
3. Route and attach a green wire from the left MP enclosure's GROUND busbar to each inverter's AC GROUND terminal.

Inverter AC Output Wiring (see Figures 3-22a.1 and 3-22a.2)

1. Route and attach a black w/white stripe wire to each inverter's AC HOT 1 OUT terminal from the left MP enclosure's INV HOT 1 OUT busbar.
2. Route and attach a red w/white stripe wire to each inverter's AC HOT 2 OUT terminal from the left MP enclosure's INV HOT 2 OUT busbar.
3. Route and attach a white wire from the left MP enclosure's AC NEUTRAL busbar to each inverter's AC NEUTRAL terminal.

Bottom AC Breaker Wiring (see Figure 3-22b)

1. Route and attach a black wire to the left MP enclosure's AC LEG 1 IN busbar from the bottom right terminal of each of the new AC input breakers.
2. Route and attach a red wire to the left MP enclosure's AC LEG 2 IN busbar from the bottom of each of the new AC input breakers.

External AC Main Panel Wiring (see Figure 3-22b)

1. Route and attach a black wire to the left MP enclosure's AC LEG 1 IN busbar from the main AC electrical panel.
2. Route and attach a red wire to the left MP enclosure's AC LEG 2 IN busbar from the main AC electrical panel.
3. Route and attach a green wire to the left MP enclosure's GROUND busbar from the main AC electrical panel's Ground busbar.
4. Route and attach a white wire to the left MP enclosure's AC NEUTRAL busbar from the main AC electrical panel's Neutral busbar.

External AC Sub-Panel Wiring (see Figure 3-22b)

1. Route and attach a black wire from the left MP enclosure's AC LEG 1 OUT busbar to the AC electrical sub-panel.
2. Route and attach a red wire from the left MP enclosure's AC LEG 2 OUT busbar to the AC electrical sub-panel.
3. Route and attach a green wire from the left MP enclosure's GROUND busbar to the AC electrical sub-panel's Ground busbar.
4. Route and attach a white wire from the left MP enclosure's AC NEUTRAL busbar to the AC electrical sub-panel's Neutral busbar.

AC Wiring Inspection

After verifying all AC connections are correct and all AC terminal screws are torqued correctly, replace the covers on the main electrical panel/sub-panel.

3.0 Installation

MPXD-30D DC Wiring

This section covers the DC wiring to/from the inverters, and from the battery bank.



WARNING: During normal operation, the terminals, busbars, and electrical components inside the MP enclosure may be energized – DO NOT TOUCH.



WARNING: Disconnect all power sources before removing the cover. Even though DC voltage is “low voltage”, significant hazards may be present, particularly from short circuits of the battery system.



CAUTION: DO NOT connect the battery cables to the battery bank until all wiring to the inverters and inside the MP/MPX enclosure is complete and the correct DC voltage and polarity have been verified.

Installing the DC Cables From the Inverters to the MP (see Figure 3-22c)

IMPORTANT: Coordinate the DC wiring to each inverter from each DC breaker such that the far left inverter (Master) is connected to the far left breaker (Master DC breaker), and the second inverter (Slave) is connected to the second DC breaker (Slave 1 DC breaker), and so on.

1. Route a DC positive cable (red) from each inverter into the MP enclosure.
2. Connect the end of the DC positive cable (red) to the inverter's positive DC terminal.
3. Connect the other end of the DC positive cable (red) to a DC circuit breaker's top terminal.
4. Route a DC negative cable (black) from each inverter into the MP enclosure.
5. Connect the end of the DC negative cable (black) to the inverter's negative DC terminal.
6. Connect the other end of the DC negative cable (black) to the top of the DC shunt's busbar.
7. Route an appropriately sized DC equipment ground wire from each new inverter's DC GROUND terminal to the DC GROUND busbar in the MP enclosure.
8. Verify all DC connections are torqued from 10 to 12 ft lbf (13.6 to 16.3 N-m).
9. Once the DC connections are correctly wired and tested, coat the terminals with an approved anti-oxidizing coating.

Installing the DC Cables From the Battery Bank to the MP Enclosure (see Figure 3-22d)

IMPORTANT: Damage may occur if DC power is connected to the MP enclosure before the Communication wiring is completed. **DO NOT** connect the DC cables from the MP enclosure to the battery bank until: 1) **all DC, AC, and Comm** wirings are completed, 2) the correct DC and AC overcurrent protection have been installed and, 3) the correct DC voltage and polarity have been verified.



WARNING: Ensure all AC and DC breakers are switched OFF before connecting or disconnecting the battery cables, and that all AC and DC power is disconnected from the inverter.



WARNING: Lethal currents will be present if the positive and negative cables attached to the battery bank touch each other. During the installation and wiring process, ensure the cable ends are insulated or covered to prevent touching/shorting the cables.



CAUTION: The Magnum inverter is NOT reverse polarity protected, if this happens the inverter will be damaged and will not be covered under warranty. Before making the final DC connection from the MP enclosure down to the battery bank, verify the correct battery voltage and polarity by using a voltmeter. If the positive (+) terminal of the battery is connected to the negative (-) busbar of the MP enclosure and vice versa, severe damage will result. Ensure the cables are color-coded to avoid polarity confusion.

1. Route a DC positive battery cable (red) from the battery bank through the bottom of the MP enclosure for each inverter.
2. Connect the end of the DC positive battery cable (red) to the DC circuit breaker's bottom battery positive connection.

3. Route a DC negative battery cable (black) from the battery bank thru the bottom of the MP enclosure for each inverter.
4. Connect the end of each DC negative battery cable (black) to the battery negative connection (DC shunt's bottom busbar).
5. Route an appropriately sized DC equipment ground wire from the ground terminal in the battery bank enclosure to the DC ground terminal in the MP enclosure.
6. Route an appropriately sized DC grounding wire (green or bare wire) from the DC GROUND busbar in the MP enclosure to the system ground (see the MP owner's manual for information on sizing and connecting the system ground wire).
7. Ensure the DC wire connections (to the inverter, DC circuit breaker, and DC shunt) are flush on the surface of the DC terminals and the hardware used to hold these connections are stacked correctly (see Figure 3-17); and then securely tighten these connections.

IMPORTANT: Only after the entire installation is complete and all connections are verified, should the DC circuit breaker be closed to provide power to the inverters.

MPXD-30D Communication Wiring

Each MPXD-30D kit includes a remote cable and a stacking cable for connecting to a router. The Magnum router comes with two CAT 5 cables and two RJ11 communication cables. The MP enclosure comes with an extension cable for connecting the inverter to a Battery Temperature Sensor (BTS).

Connecting Remote Cables to the Router (see Figure 3-22e)

1. Using the supplied RJ11 remote cables, route a cable from each inverter to the attached router.
2. Connect one end of each remote cable to the Remote port (blue label) on each installed inverter.
3. Connect the other end of each remote cable to its respective port (P1-P6) on the router.



Info: It is recommended that the Master inverter be connected to Port 1, Slave 1 to Port 2 etc., in order to keep track of which inverter is displayed on each port.

Connecting Stacking Cables to the Router (see Figure 3-22e)

1. Using the supplied stacking (CAT 5) cables, route a cable from each inverter to the attached router.
2. Connect one end of each stacking cable to the Stack Port (red label) on each installed inverter.
3. Connect the other end of each stacking cable to its respective CAT 5 port on the router (MA, SL1, SL2, and SL3 ports for the appropriate number of installed inverters).



Info: At least one CAT 5 cable **must** be plugged into the router's MA port in order for the router to operate any inverters.

Battery Temperature Sensors (BTS) (see Figures 22e)

The Battery Temperature Sensor provides the inverter with precise battery temperature information that enables the batteries to be correctly charged under extreme temperature changes. If the BTS is not installed and batteries are subjected to large temperature changes, battery life may be shortened.

1. Using the supplied extension cable, route it from the Master inverter through the MPX and MP enclosure to the battery bank.
2. Connect one end of the extension cable to the Battery Temp Sensor port (yellow label) on the Master inverter.
3. Connect the other end of the extension cable to the RJ-11 connector on a BTS (connected to the battery bank).

Connecting the DC Cables from the MP Enclosure to the Battery Bank

Once all the wiring is completed, connect the DC cables from the MP enclosure to the battery bank.

3.0 Installation

| WIRE | FROM INVERTER: | TO MPDH-30D: |
|----------------|----------------|----------------------|
| RED w/STRIPE | AC OUTPUT | INV HOT 2 OUT busbar |
| BLACK w/STRIPE | AC OUTPUT | INV HOT 1 OUT busbar |
| WHITE | AC OUTPUT | AC NEUTRAL busbar |
| RED | AC INPUT | AC INPUT breaker |
| BLACK | AC INPUT | AC INPUT breaker |
| GREEN | AC INPUT | GROUND busbar |

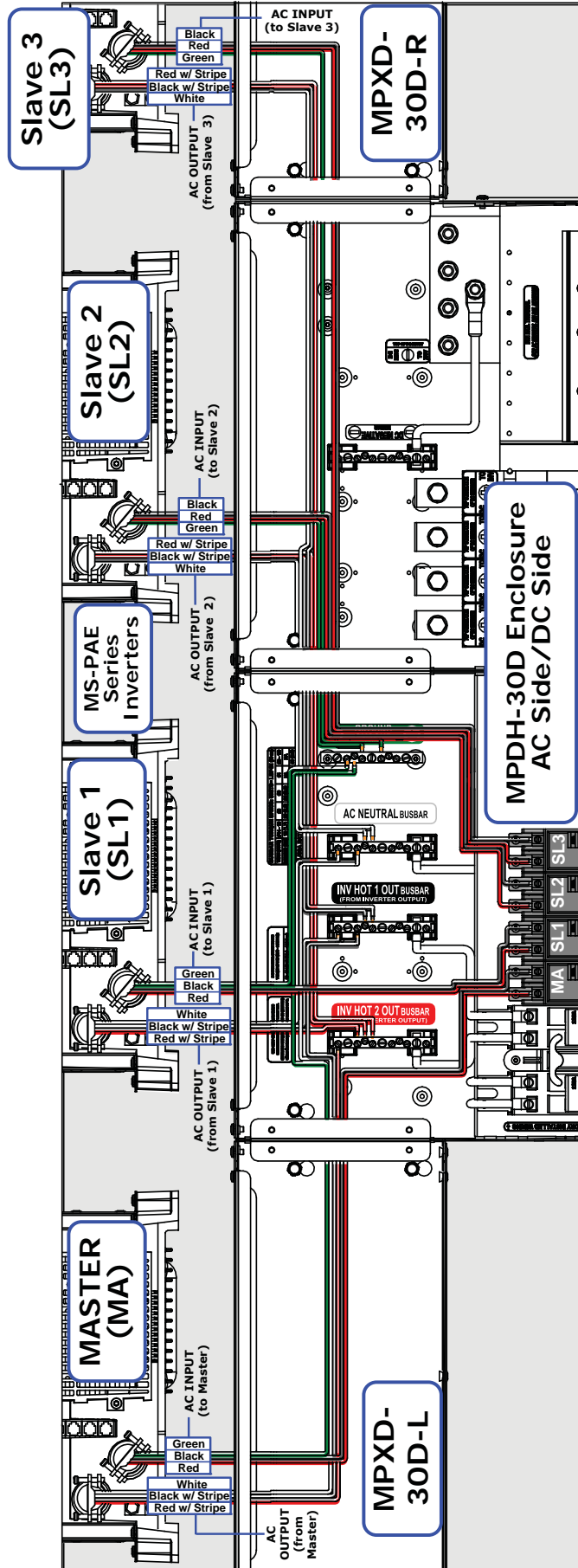

See Figure 3-22a.2 for a closeup



Figure 3-22a.1, MPXD-30D / MPDH-30D Inverter AC Wiring

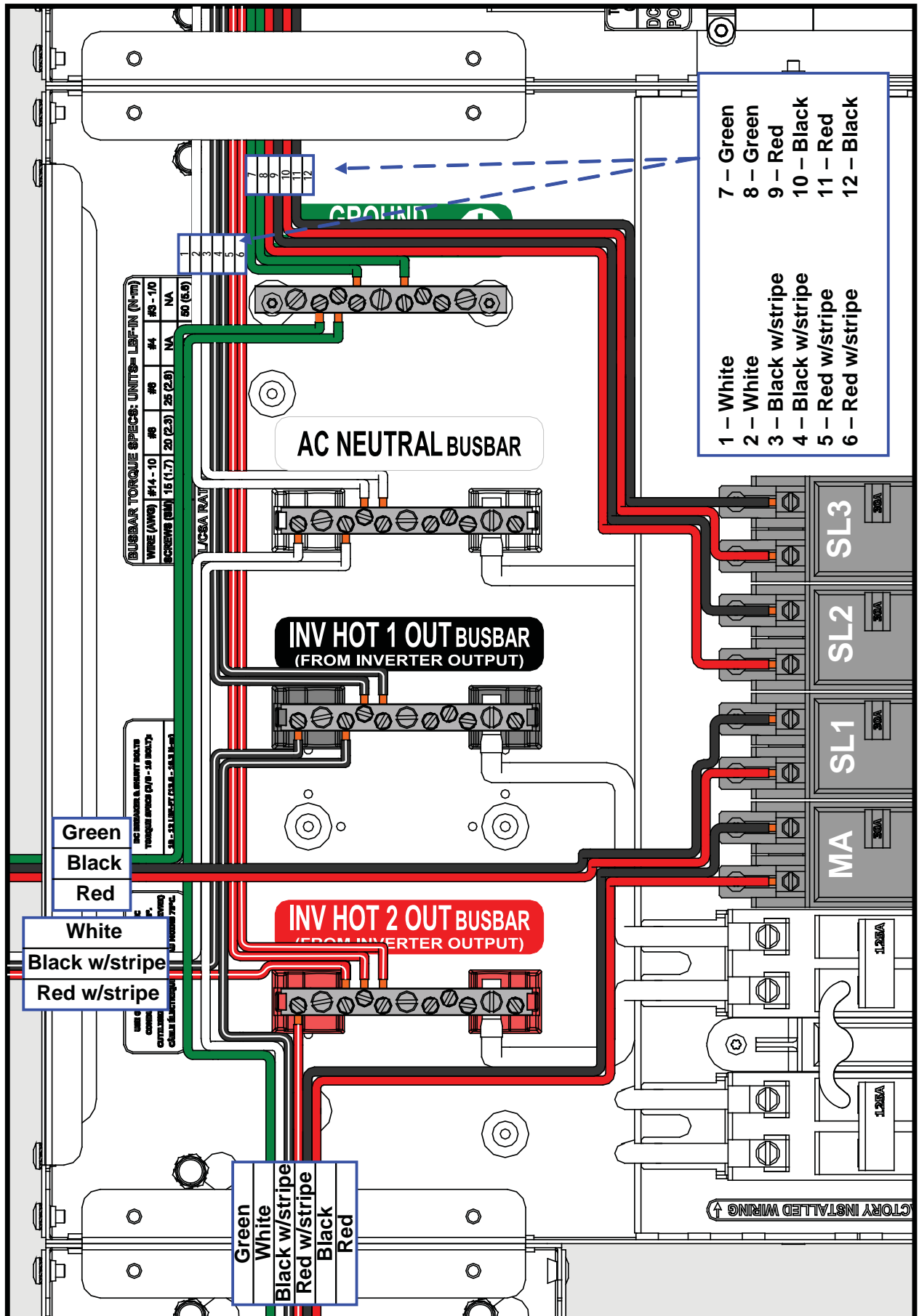

Figure 3-22a.2, MPXD-30D / MPDH-30D Inverter AC Wiring (Closeup)

3.0 Installation

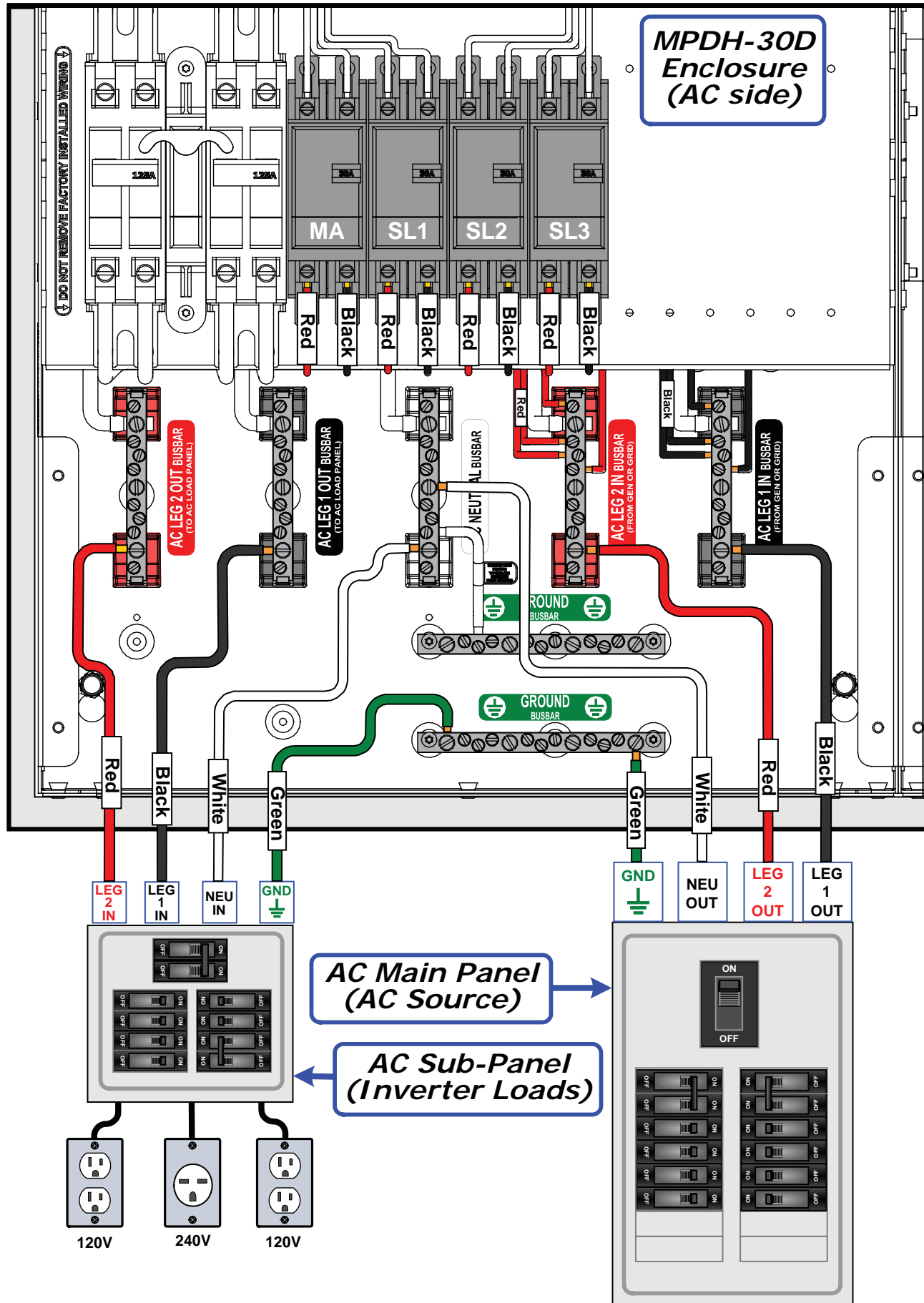

Figure 3-22b, MPXD-30D / MPDH-30D External AC Wiring

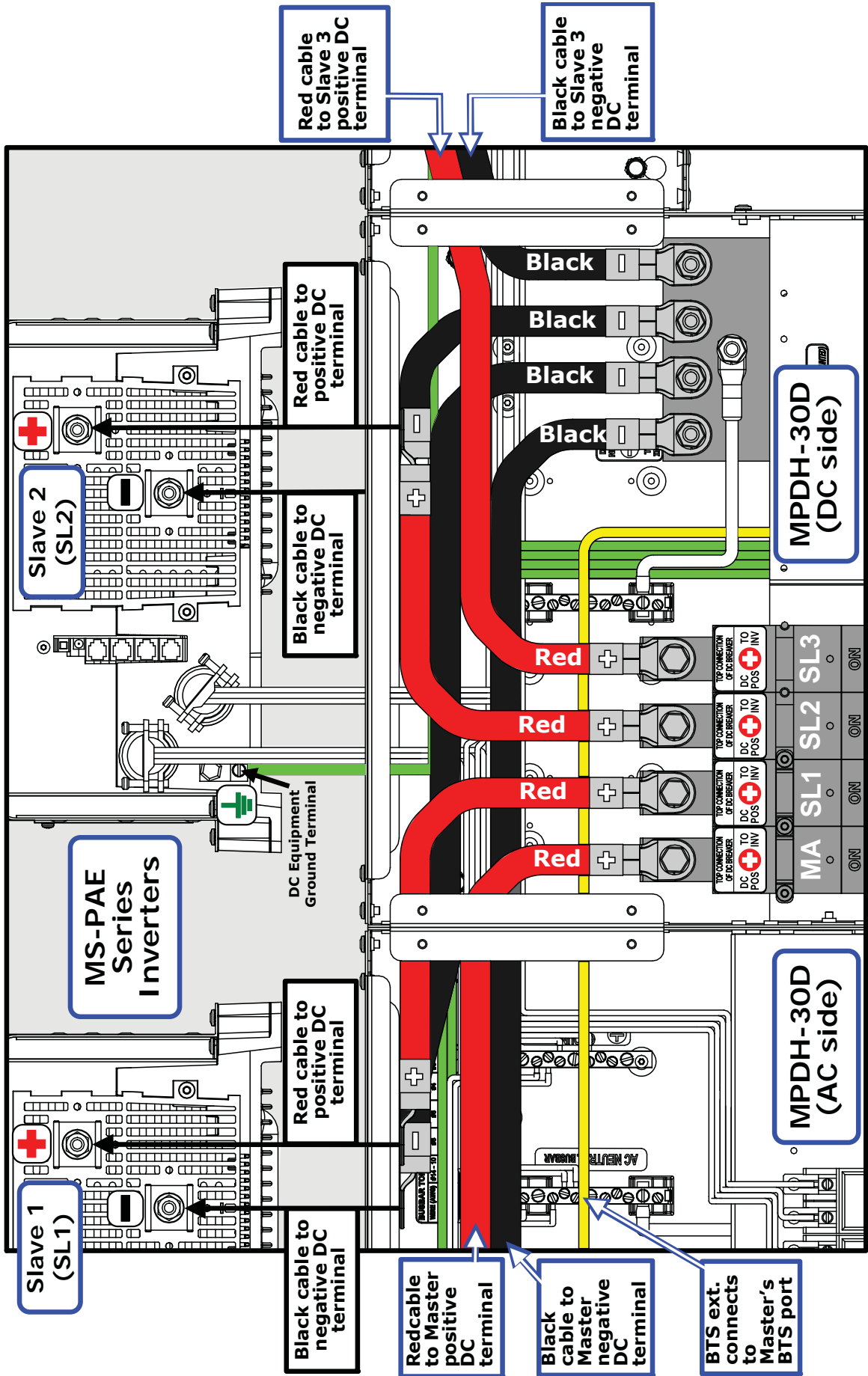

Figure 3-22c, MPXD-30D / MPDH-30D Inverter DC Wiring

3.0 Installation

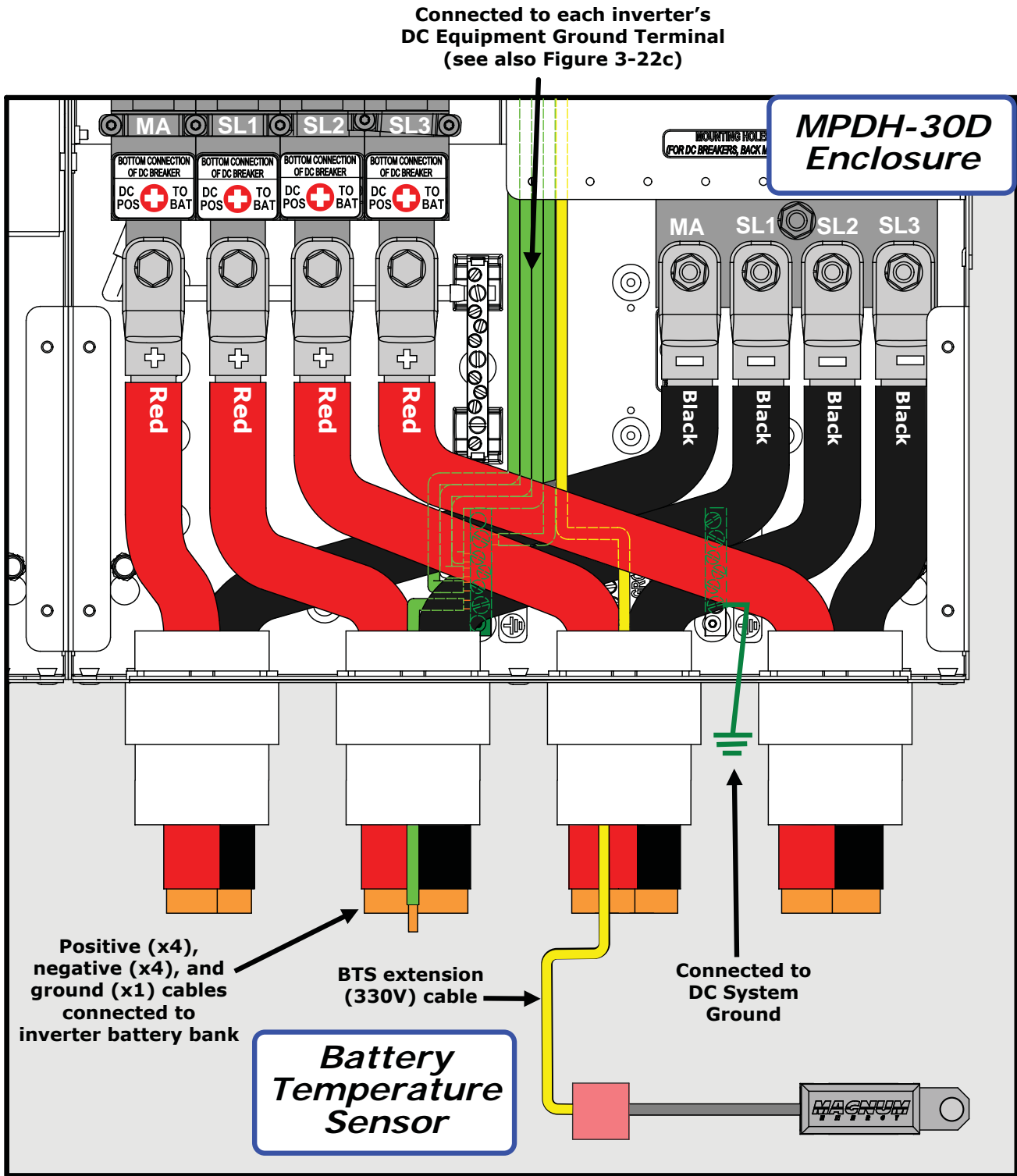

Figure 3-22d, MPXD-30D / MPDH-3D Battery Bank DC Wiring

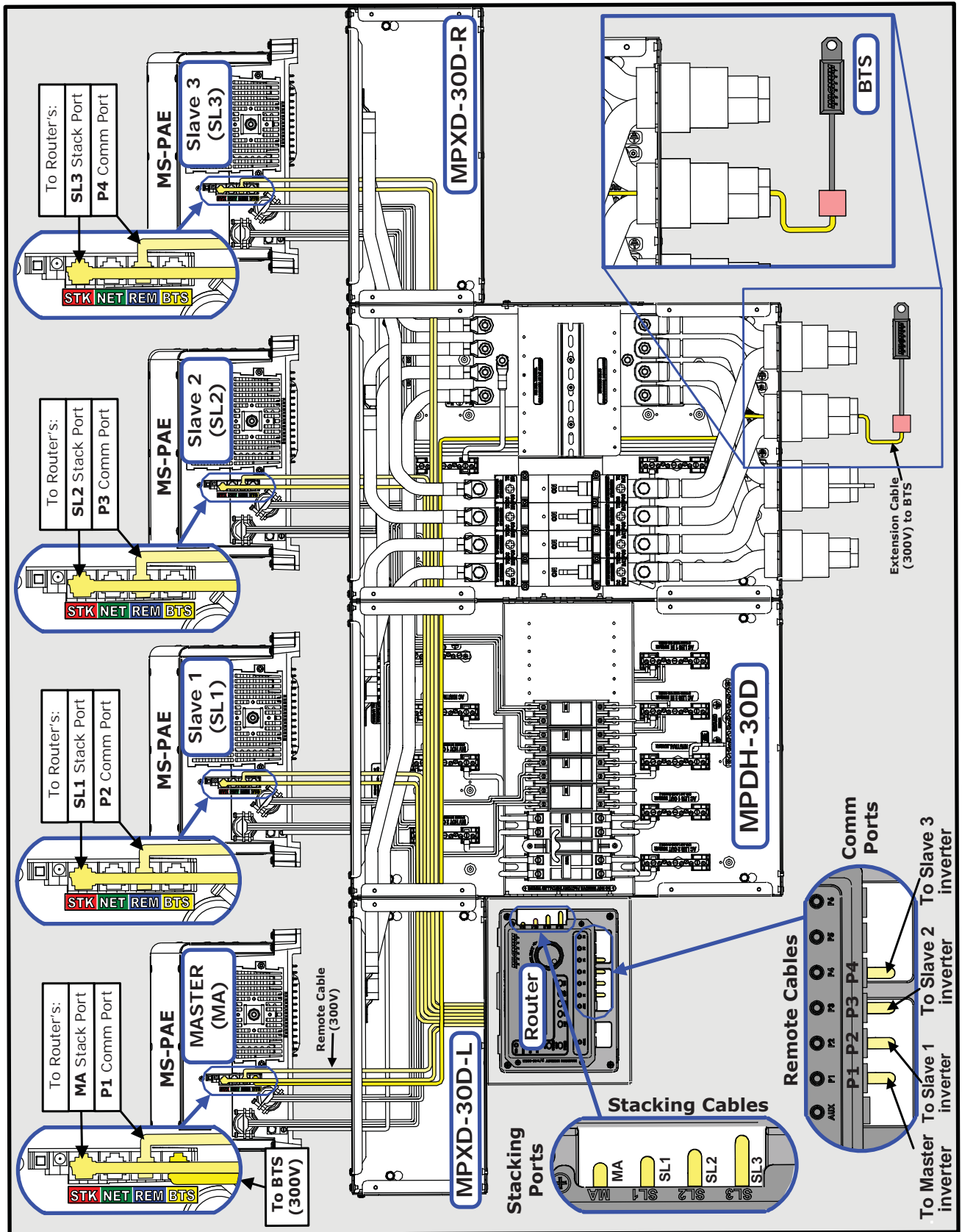

Figure 3-22e, MPXD-30D / MPDH-30D Communication Wiring

3.0 Installation

3.3 Installation Checklist

After all electrical connections from the MP enclosure to the inverters, batteries, AC source, and sub-panel have been completed, refer to the installation checklist in Section 3.13 of your MP Enclosure Owner's Manual (PN: 64-0028) to confirm proper installation.

3.4 Functional Test

Once you confirm that the system has been installed properly, you are ready to perform a functional test. Refer to the functional test procedure in Section 3.14 of your MP Enclosure Owner's Manual.



WARNING: During the functional test – because the front cover has been removed – you are exposed to potential dangerous voltages and shock hazards inside the MP enclosure that may cause damage, injury, or death. If you do not have experience working with AC and DC voltage circuits, do not attempt this test – use an experienced electrical installer.



CAUTION: During the functional test, if any step cannot be verified or is incorrect, stop and recheck/correct the connections before proceeding to the next step.

3.5 Attaching Labels and Covers

The MPX kit has labels for the DC breaker's positive cable connections (see Figure 2-2). The "Top Connection of DC Breaker" label affixes to the top of the new DC breaker. The "Bottom Connection of DC Breaker" label affixes to the bottom of the new DC breaker. Refer to Figure 3-23 for proper placement of both labels.

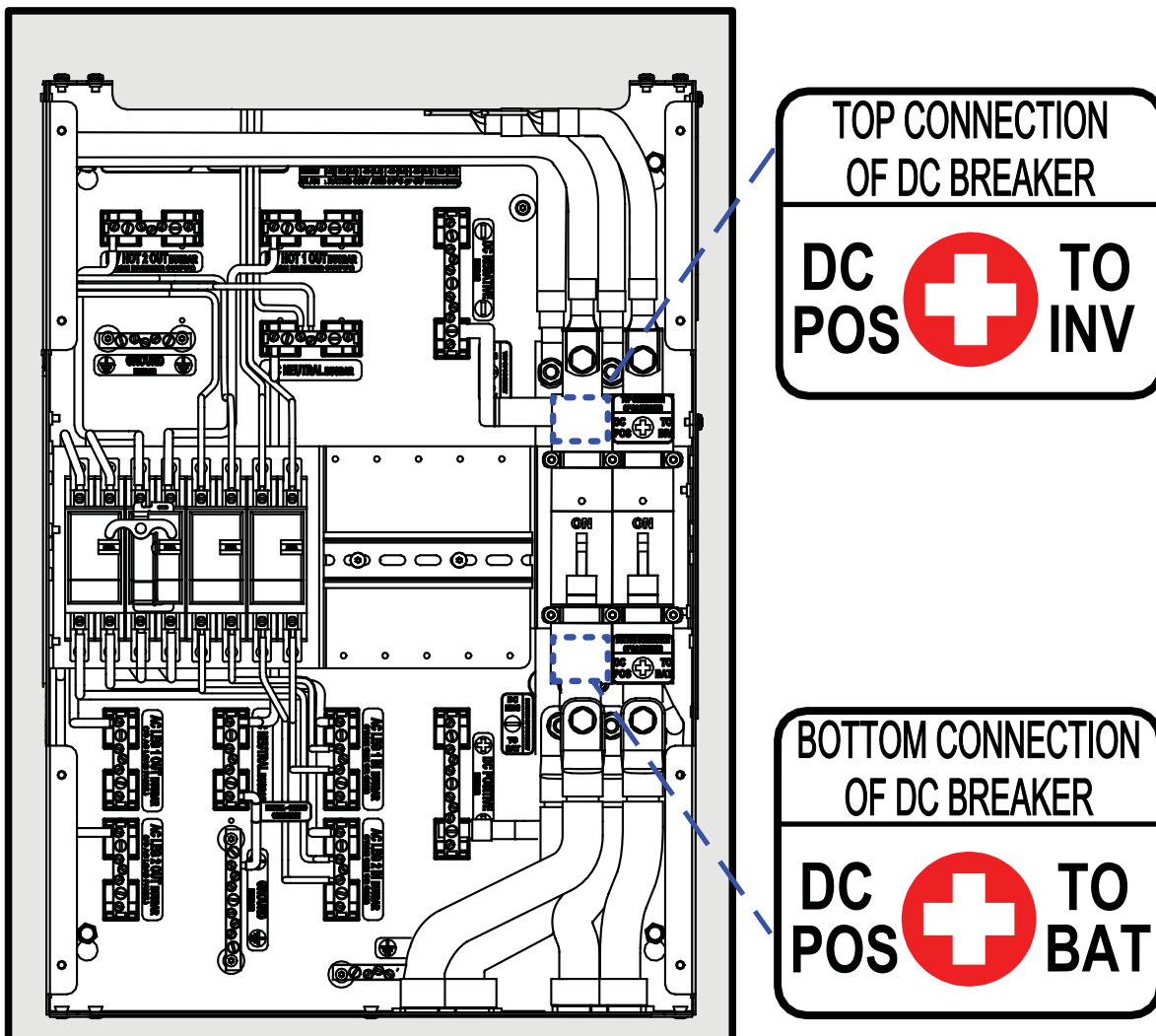

Figure 3-23, Attaching the Interior DC Labels

Attaching Covers

MP Enclosure - Use the supplied screws and washers to secure the MP enclosure's cover (see Figure 3-24).

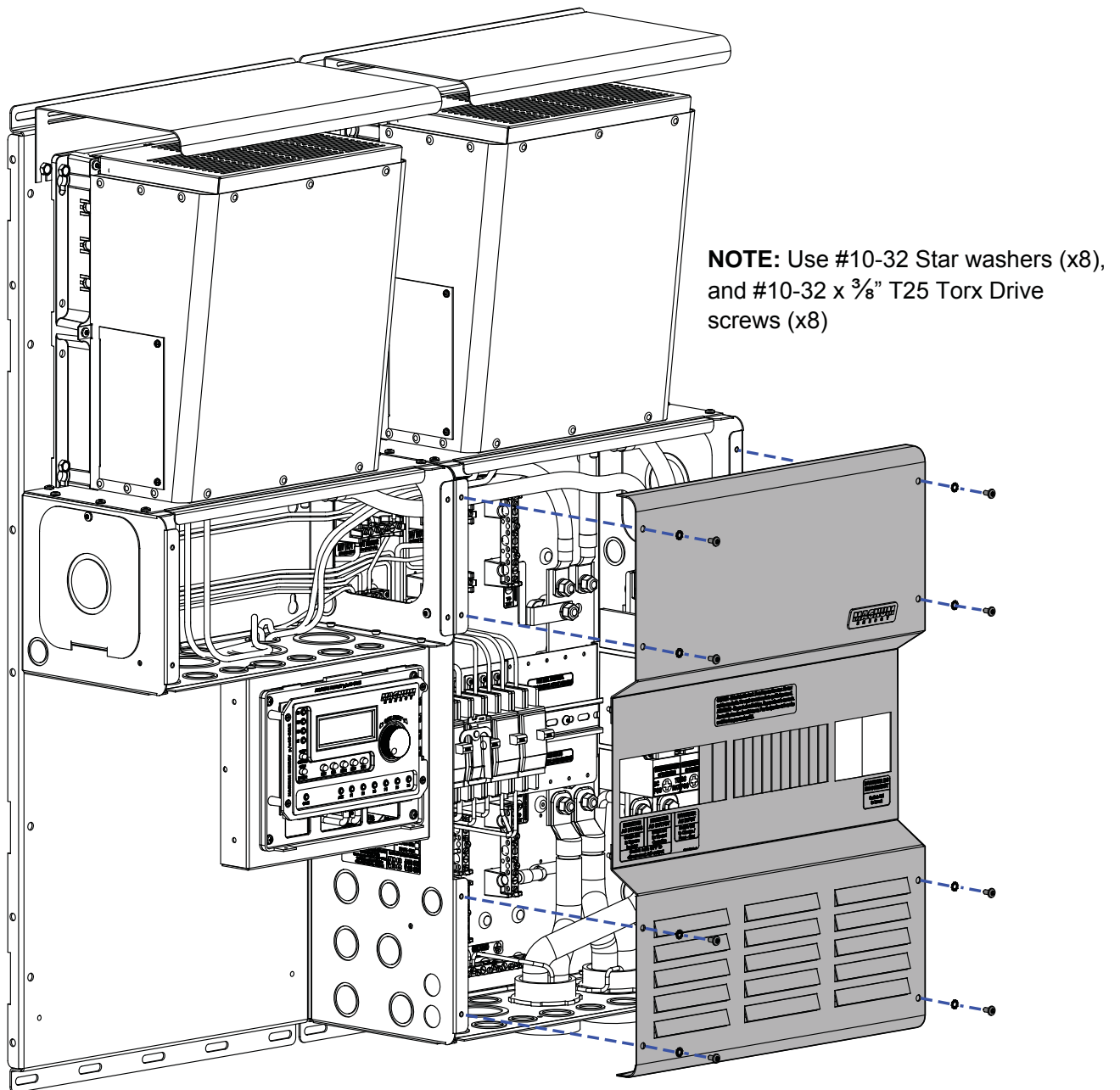
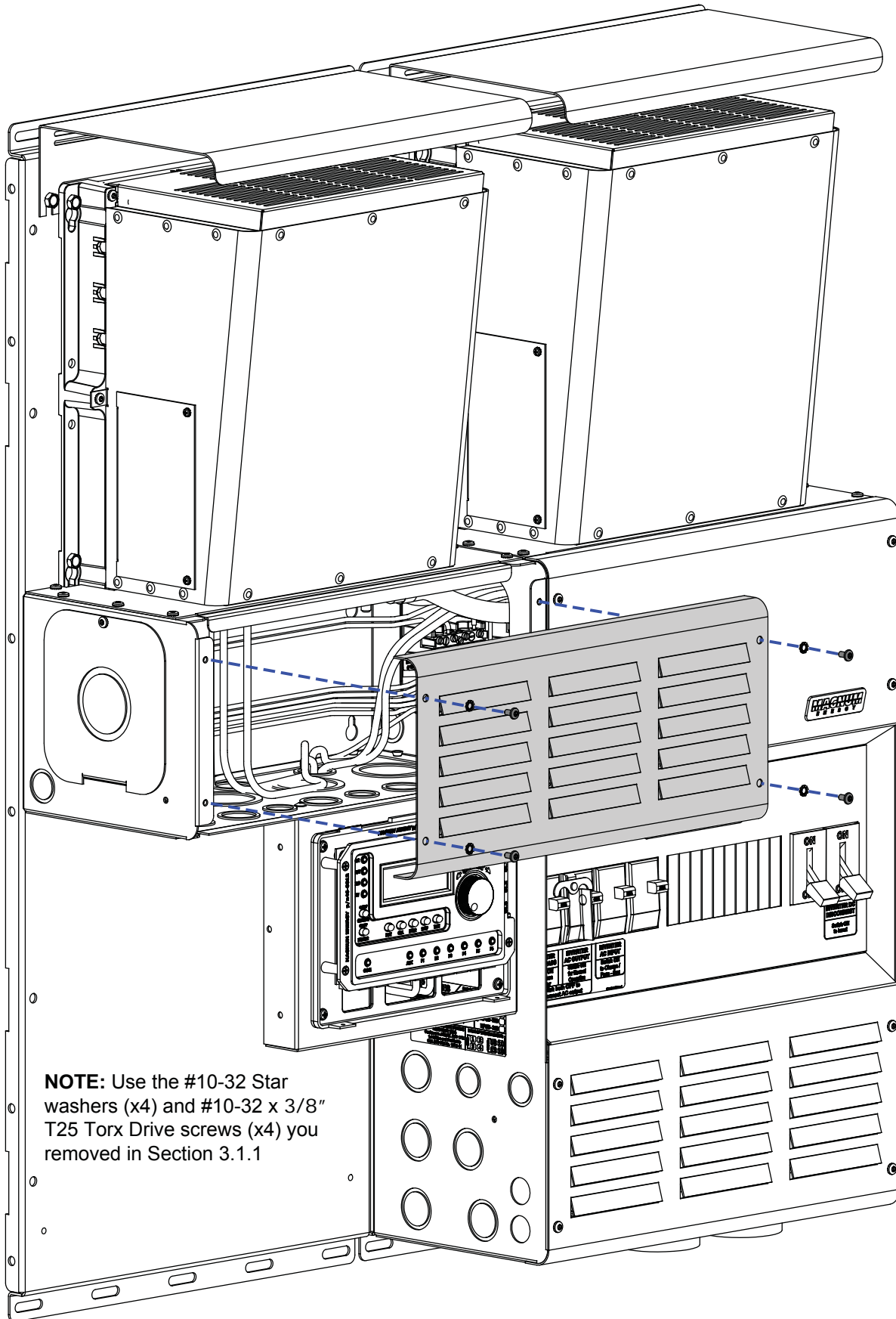

Figure 3-24, Attaching the MP Enclosure Cover

3.0 Installation

MPX - Use the front cover screws and washers that you removed earlier (Section 3.1.1) to reattach the MPX extension's cover (see Figure 3-25).



NOTE: Use the #10-32 Star washers (x4) and #10-32 x 3/8" T25 Torx Drive screws (x4) you removed in Section 3.1.1

Figure 3-25, Attaching the MPX Cover

Router - Use the supplied screws and washers (x2) to secure the router's cover (see Figure 3-26).

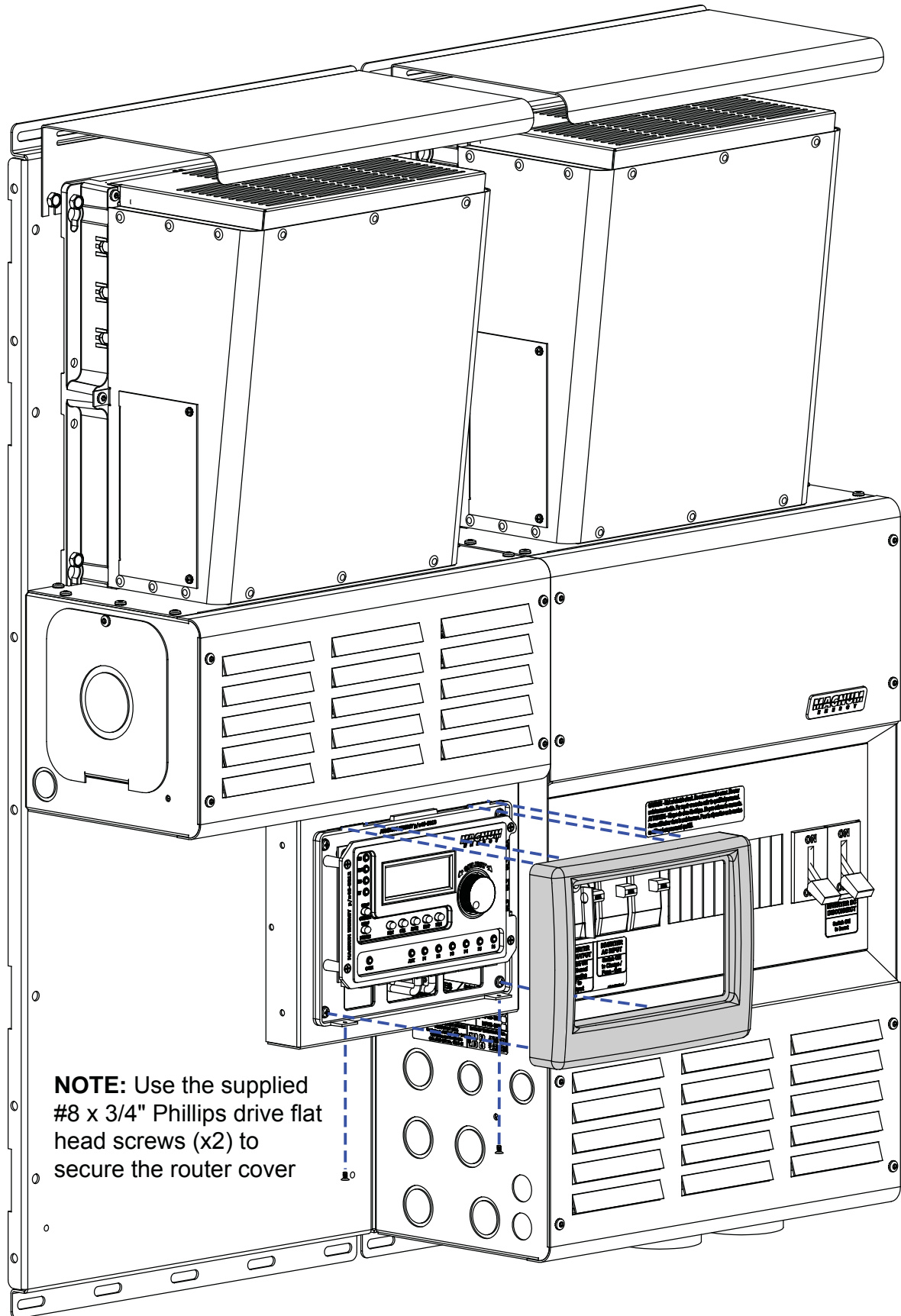

Figure 3-26, Attaching the Router Cover

3.0 Installation

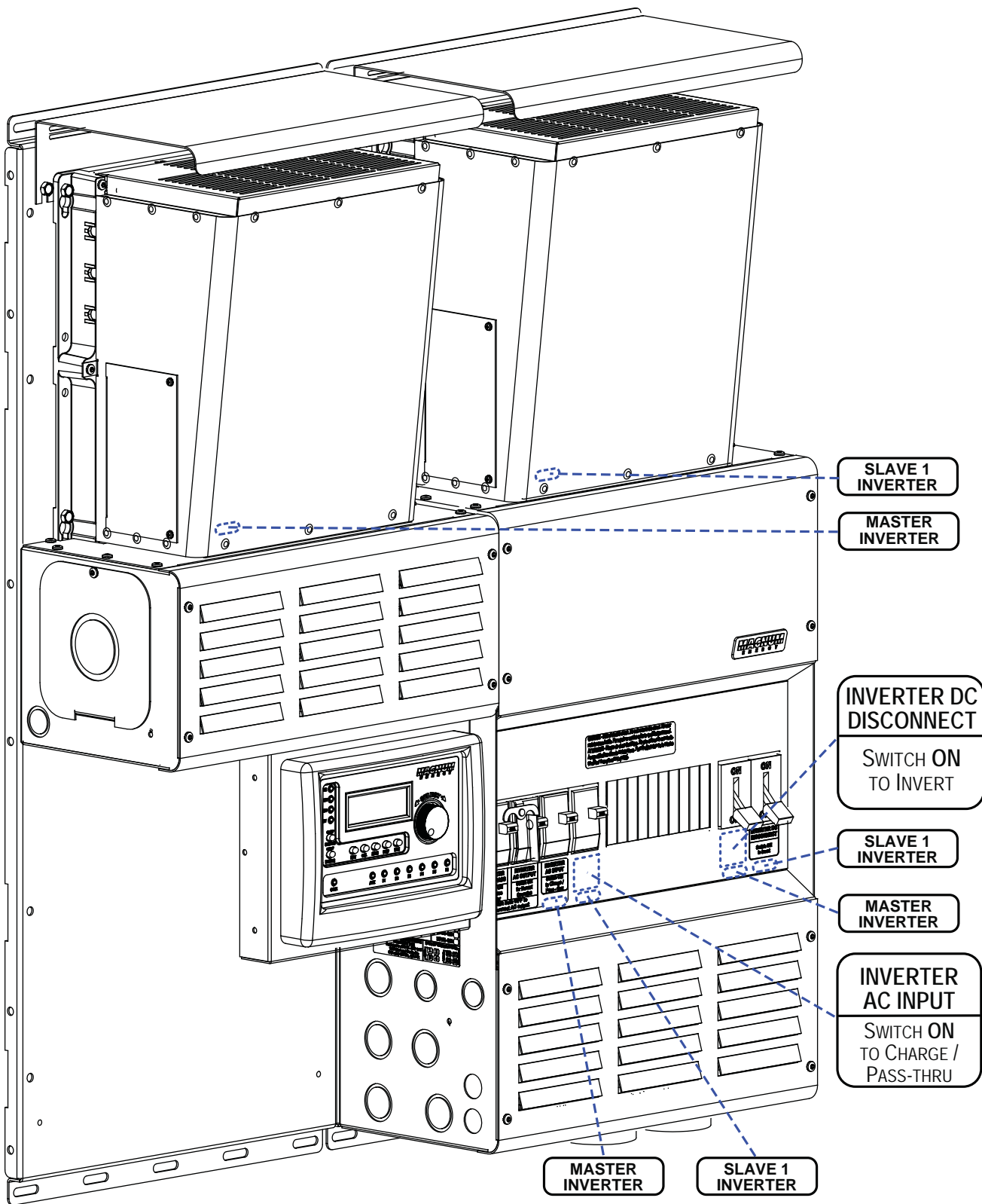

Figure 3-27, Attaching the Exterior Labels MPSL/MPSH

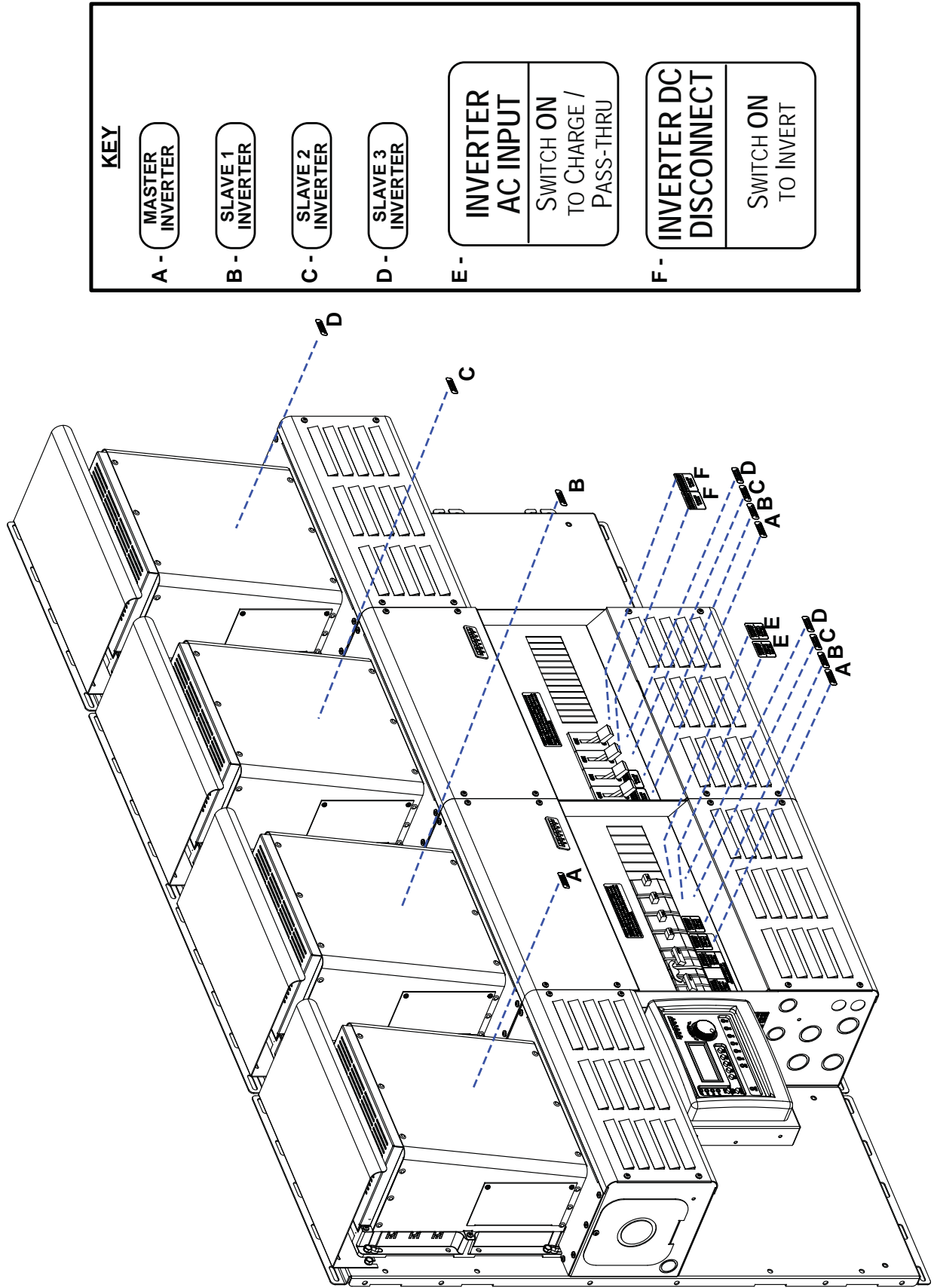

Figure 3-28, Attaching the Exterior Labels MPDH

4.0 Warranty and Service Information

4.0 Warranty and Service Information

4.1 Limited Warranty

Magnum Energy, Inc., warrants the MPX Extension Kit to be free from defects in material and workmanship that result in product failure during normal usage, according to the following terms and conditions:

1. The limited warranty for the product extends for 12 months beginning from the product's original date of purchase.
2. The limited warranty extends to the original purchaser of the product and is not assignable or transferable to any subsequent purchaser.
3. During the limited warranty period, Magnum Energy will repair, or replace at Magnum Energy's option, any defective parts, or any parts that will not properly operate for their intended use with factory new or remanufactured replacement items if such repair or replacement is needed because of product malfunction or failure during normal usage. The limited warranty does not cover defects in appearance, cosmetic, decorative or structural parts or any non-operative parts. Magnum Energy's limit of liability under the limited warranty shall be the actual cash value of the product at the time the original purchaser returns the product for repair, determined by the price paid by the original purchaser. Magnum Energy shall not be liable for any other losses or damages.
4. Upon request from Magnum Energy, the original purchaser must prove the product's original date of purchase by a dated bill of sale, itemized receipt.
5. The original purchaser shall return the product prepaid to Magnum Energy in Everett, WA. After the completion of service under this limited warranty, Magnum Energy will return the product prepaid to the original purchaser via a Magnum-selected non-expedited surface freight within the contiguous United States and Canada; this excludes Alaska and Hawaii.
6. This limited warranty is voided if:
 - the product has been modified without authorization
 - the serial number has been altered or removed
 - the product has been damaged from abuse, neglect, accident, high voltage or corrosion
 - the product was not installed and operated according to the owner's manual

4.2 How to Receive Repair Service

If your product requires warranty service or repair, contact either:

1. An Authorized Service Center, which are listed on the Magnum Energy website at www.magnumenergy.com/servicecenters.htm; or
2. Magnum Energy, Inc. at:

Telephone: 425-353-8833
Fax: 425-353-8390
Email: warranty@magnumenergy.com

If returning the product directly to Magnum Energy for repair, you must:

- return the unit in the original, or equivalent, shipping container
- ensure the product is properly packaged, **any damage due to inadequate packaging is not covered under warranty**
- receive a Return Materials Authorization (RMA) number from the factory prior to the return of the product to Magnum Energy for repair
- place RMA numbers clearly on the shipping container or on the packing slip

**BEFORE RETURNING ANY UNIT TO MAGNUM ENERGY INC.,
A RETURN MATERIAL AUTHORIZATION (RMA) NUMBER IS REQUIRED.**

