



# ME-SSI

## Series Stacking Interface



# Owner's Manual

## **Disclaimer of Liability**

The use of this manual and the conditions or methods of installation, operation, use, and maintenance of the ME-SSI (Series Stacking Interface) are beyond the control of Magnum Energy, Inc. Therefore, this company assumes no responsibility and expressly disclaims any liability for loss, damage, or expense whether direct, indirect, consequential, or incidental that may arise out of or be in any way connected with such installation, operation, use, or maintenance.

Due to continuous improvements and product updates, the images shown in this manual may not exactly match the unit purchased.

## **Restrictions on Use**

The ME-SSI may only be used in life-support devices or systems with the express written approval of Magnum Energy. Failure of the ME-SSI can reasonably be expected to cause the failure of that life-support device or system, or to affect the safety or effectiveness of that device or system. If the ME-SSI fails, it is reasonable to assume that the health of the user or other persons may be endangered.

## **Contact Information**

Magnum Energy, Inc.  
2211 West Casino Rd.  
Everett, WA 98204  
Phone: (425) 353-8833  
Fax: (425) 353-8390  
Web: [www.magnumenergy.com](http://www.magnumenergy.com)

## **Revisions Required**

Your MS4024 inverter and remote control (if used) must have the correct revision level in order to work in a series stacked configuration. The MS4024 requires a revision of 2.0 or higher. To use a remote control (i.e., ME-RC50 or ME-ARC) with this product, you need a revision of 1.2 or higher.

## Safety symbols

To reduce the risk of electrical shock, fire, or other safety hazard, the following safety symbols have been placed throughout this manual to indicate dangerous and important safety instructions.



**WARNING:** This symbol indicates that failure to take a specified action could result in physical harm to the user.



**CAUTION:** This symbol indicates that failure to take a specified action could result in damage to the equipment.



**Info:** This symbol indicates information that emphasizes or supplements important points of the main text.

## IMPORTANT PRODUCT SAFETY INSTRUCTIONS

This manual contains important safety instructions that must be followed during the installation and operation of this product. Read all instructions and safety information contained in this manual before installing or using this product.

- All electrical work must be performed in accordance with local, state, and federal electrical codes.
- This product is designed for indoor/compartments installation. DO NOT expose to rain, snow, moisture, or liquids of any type.
- Use insulated tools to reduce the chance of electrical shock or accidental short circuits.
- Remove all jewelry such as rings, watches, bracelets, etc., when installing or performing maintenance on an inverter.
- Always disconnect the batteries or energy source prior to installing or performing maintenance on an inverter. Live power may be present at more than one point since an inverter utilizes both batteries and AC. Turning off the inverter may not reduce this risk. As long as AC power is connected, it will pass through the inverter regardless of the ON/OFF power switch setting.
- Always verify proper wiring prior to starting an inverter.
- Do not operate an inverter if it has been damaged.
- Do not dismantle an inverter; there are no user-serviceable parts contained in this product. Attempting to service the unit yourself could cause electrical shock. Internal capacitors remain charged after all power is disconnected.
- No AC or DC disconnects are provided as an integral part of the inverter. Both AC and DC disconnects must be provided as part of the system installation.

- No overcurrent protection for the battery supply is provided as an integral part of the inverter. Overcurrent protection of the battery cables must be provided as part of the installation.
- No overcurrent protection for the AC output wiring is provided as an integral part of the inverter. Overcurrent protection of the AC output wiring must be provided as part of the installation.

## **IMPORTANT BATTERY SAFETY INSTRUCTIONS**

- Wear eye protection (safety glasses) when working with batteries.
- Remove all jewelry such as rings, watches, bracelets, etc., when installing or performing maintenance on the inverter.
- Never work alone. Always have someone near you when working around batteries.
- Use proper lifting techniques when working with batteries.
- Never use old or untested batteries. Check each battery's label for age, type, and date code to ensure all batteries are identical.
- Batteries are sensitive to changes in temperature. Always install batteries in a stable environment.
- Install batteries in a well ventilated area. Batteries can produce explosive gasses. For compartment or enclosure installations, always vent batteries to the outside.
- Provide at least one inch of air space between batteries to provide optimum cooling.
- Never smoke when in the vicinity of batteries.
- To prevent a spark at the battery and reduce the chance of explosion, always connect the cables to the batteries first. Then connect the cables to the inverter.
- Use insulated tools at all times.
- Always verify proper polarity and voltage before connecting the batteries to the inverter.
- To reduce the chance of fire or explosion, do not short-circuit the batteries.
- In the event of accidental exposure to battery acid, wash thoroughly with soap and water. In the event of exposure to the eyes, flood them for at least 15 minutes with running water and seek immediate medical attention.
- Recycle old batteries.

## **SAVE ALL INSTRUCTIONS**

## Table of Contents

<b>Introduction</b> .....	<b>1</b>
<b>Installation</b> .....	<b>2</b>
DC Wiring.....	2
Battery Connections for Series Stacked Inverters .....	3
DC Wiring Using One Battery Cable Pair .....	4
DC Wiring Using Two Battery Cable Pairs .....	5
Incorrect DC Wiring .....	6
The Stacker Cable .....	7
Connecting the Series Stacking Cable .....	7
AC Wiring.....	8
AC Input Source .....	8
AC Input .....	9
AC Output.....	10
AC Terminal Block .....	10
Determine Which AC Wiring Configuration to Use.....	11
Neutral to Safety Ground Bonding (Mobile applications).....	13
Grounding.....	14
<b>Operation</b> .....	<b>15</b>
Using the Remote Control.....	15
Functional Test.....	15
Power-up Sync Test.....	16
Testing Invert Mode.....	16
Testing AC Transfer/Charge Mode .....	17
Inverter Operation.....	18
Charger Operation.....	18
<b>Troubleshooting</b> .....	<b>20</b>
Inverter Faults .....	20
Stacking Faults .....	20
Troubleshooting Tips.....	20
<b>Warranty/Service Information</b> .....	<b>21</b>
How to Receive Repair Service .....	22

## Table of Figures

Figure 1, Series Stacking Interface (ME-SSI) Components.....	1
Figure 2, ME-SSI Components Connected to Stacked Pair .....	3
Figure 3, DC Wiring Using One Battery Cable Pair .....	4
Figure 4, DC Wiring Using Two Battery Cable Pairs .....	5
Figure 5, Incorrect DC Wiring .....	6
Figure 6, Stack Port Location (on MS4024).....	7
Figure 7, Single In/Single Out (30A with 120/240VAC source) ....	11
Figure 8, Single In/Single Out (30A with 120VAC only source) ....	11
Figure 9, Single In/Single Out (60A with 120/240VAC source) ....	12
Figure 10, Single In/Single Out (60A with 120VAC only source) ..	12
Figure 11, AC Wiring compartment (MS4024 model) .....	14

## Introduction

### Introduction

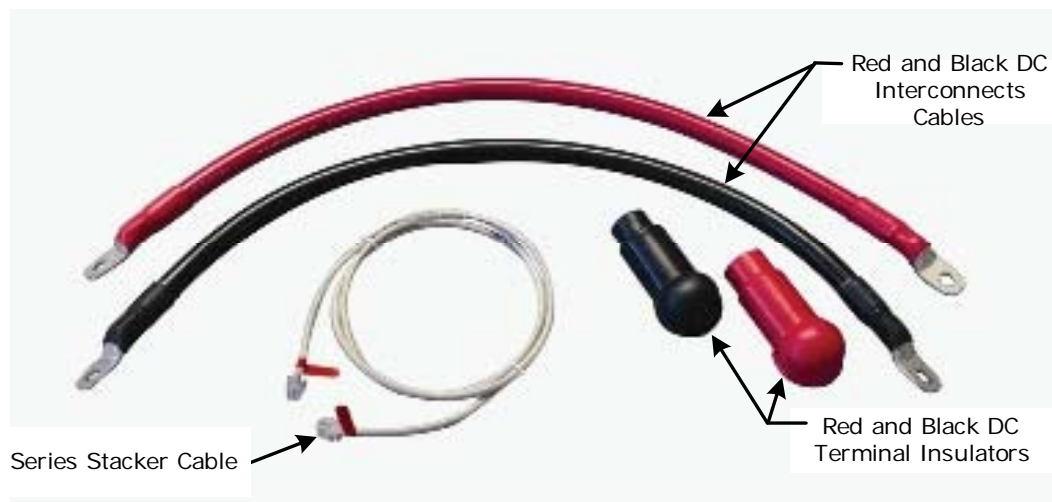
Magnum Energy's Series Stacking Interface (ME-SSI) kit allows two MS4024 models to be connected together in a "series stacked" configuration to provide 120VAC and 240VAC outputs. When connected together in a series, the AC output of each inverter continues to provide 120VAC, but the two 120VAC output waveforms are also phase locked and synchronized 180° out-of-phase from each other to provide 240VAC. This is commonly referred to as a 120/240VAC split-phase or as a 240VAC single-phase with a center-tap neutral, and is the same AC voltage configuration that most utility companies connect to houses.

While inverting, a series stacked configuration allows you to operate 240VAC loads at twice the power that is available from a single inverter; and, the ability to provide the power of each inverter separately to operate 120VAC loads.

While charging, a series stacked configuration allows the battery bank to be independently charged up to twice the power available from a single inverter; and if needed, provides back-up power for your 120/240VAC loads during a utility black-out.

The ME-SSI kit consists of:

- ME-SSI Owner's Manual
- Two DC interconnects cables (red and black)
- Two DC terminal insulators (red and black)
- Series Stacker cable



**Figure 1, Series Stacking Interface (ME-SSI) Components**

## Installation

When connecting inverters in a series stacked configuration, certain installation requirements are needed to obtain optimum performance.

This section provides information on DC and AC wiring and connecting the stacker cable. Use the information in this section along with the installation requirements provided in the owner's manual for your inverter to ensure a successful installation.

### IMPORTANT - Before you begin your installation:

- Series stacking allows two MS4024 (120VAC inverters) to be combined to provide a higher AC voltage (two MS4024 series stacked = 8000 watts @ 120/240VAC). Magnum also has inverters that can be installed in a configuration known as "parallel stacking". This configuration allows you to increase your inverter output power using a maximum of four MS-PAE units. For example, four MS4024PAE Series inverters (using the ME-RTR router) can be combined to provide 16,000 watts of inverter power (MS4024PAE x 4 = 16,000 watts @ 120/240VAC).



**Info:** The MS4024 (120VAC unit) **cannot** be reconfigured to allow parallel stacking. Only the MS-PAE Series (MS4024PAE or MS4448PAE) can be paralleled stacked.



**CAUTION:** All wiring must be done in accordance with local and national electrical safety standards.

## DC Wiring

The success of an inverter system installed in a series stacked configuration is dependent on the quality and maintenance of the DC connections and proper cable sizing. When inverters are stacked and required to perform optimally, the DC connections must be tight and the cables must not be too long or undersized. Refer to the owner's manual for your inverter to determine the required cable size and overcurrent protection device for each inverter.

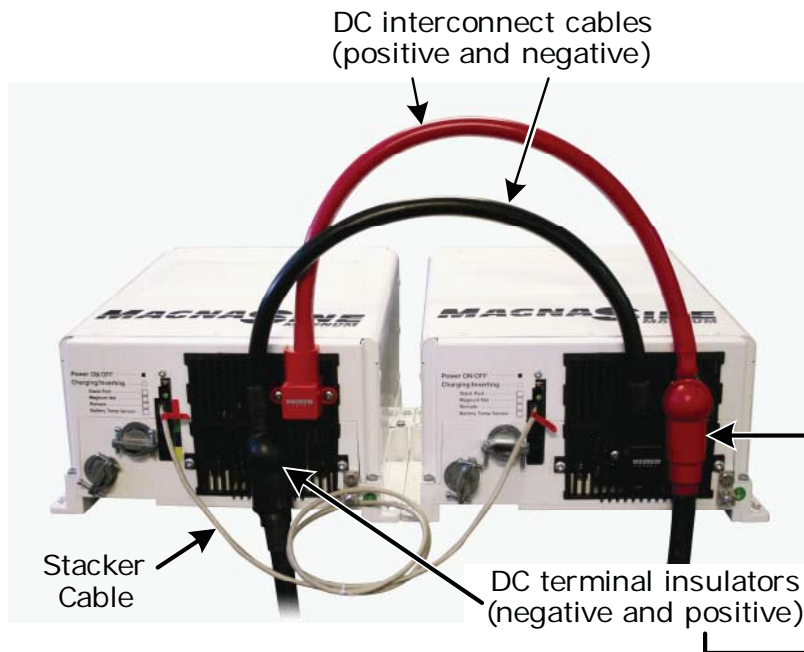


**CAUTION:** Before making any DC connection, ensure the cable polarity at both the battery and the inverter are correct. Positive must be connected to positive; negative must be connected to negative. Reversing the positive and negative battery cables will damage the inverter. This type of damage is easily detected and will void your warranty.

For help against accidental shorts, the ME-SSI kit provides two DC terminal insulators. These are to be used where both the battery cables and DC interconnects are connected (see Figure 2). Alternately, a DC Conduit Box (PN: ME-CB) or Mini Magnum Panel (MMP250-60S) may be used to protect the DC terminals.



## Installation



**Figure 2, ME-SSI Components Connected to Stacked Pair**

### Battery Connections for Series Stacked Inverters

When inverters are series stacked, they must operate from a single battery bank. A single battery bank configuration helps to balance charging and discharging. If your battery bank uses multiple battery strings (i.e., batteries connected together in series to provide the required DC voltage), ensure each battery string is connected together in parallel to form a single battery bank.

**For example:** If you have eight 6 volt batteries and require a 24 volt battery bank, connect four of the 6 volt batteries together to make 24 volts. This is known as a series battery string. The other four 6 volt batteries connected together will also make another series battery string. The negative ends of these two battery strings must be connected together. Likewise, the positive ends of the two battery strings must be connected together. Then, the two battery strings are connected together in parallel to make a single battery bank to power the stacked inverters (as shown in Figures 3 and 5).

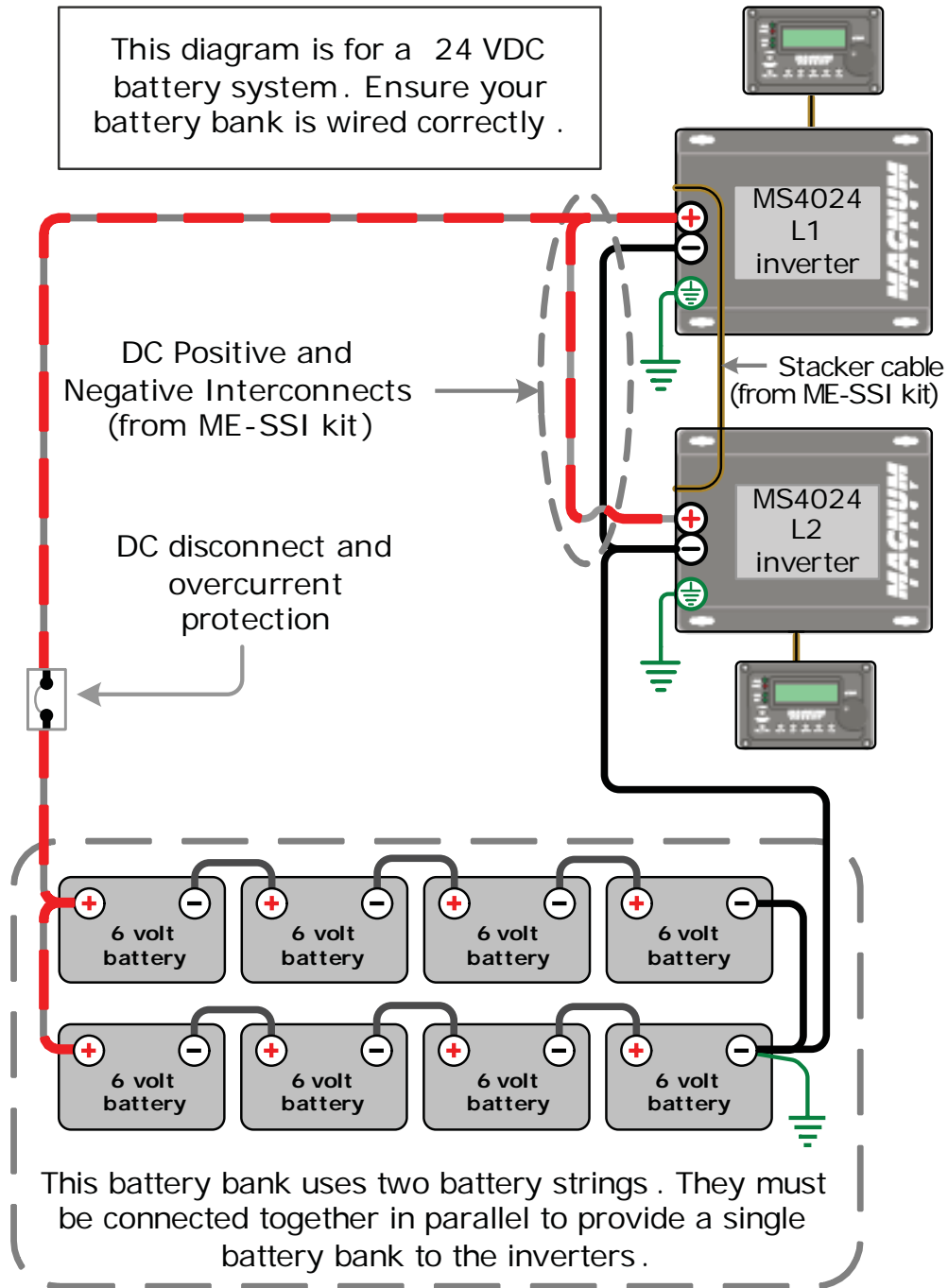


**CAUTION:** The DC negative interconnect cable provided in the ME-SSI kit is a crucial part of the DC wiring and must be used. It ensures that the negative battery terminals of both inverters are at the same voltage potential. This allows proper communication of the clocking signals and helps prevent damage to the stacking ports.



**Info:** If multiple battery temperature sensors are installed, ensure that they are all connected to the battery bank in the same location. This will help balance the charging from each charger.

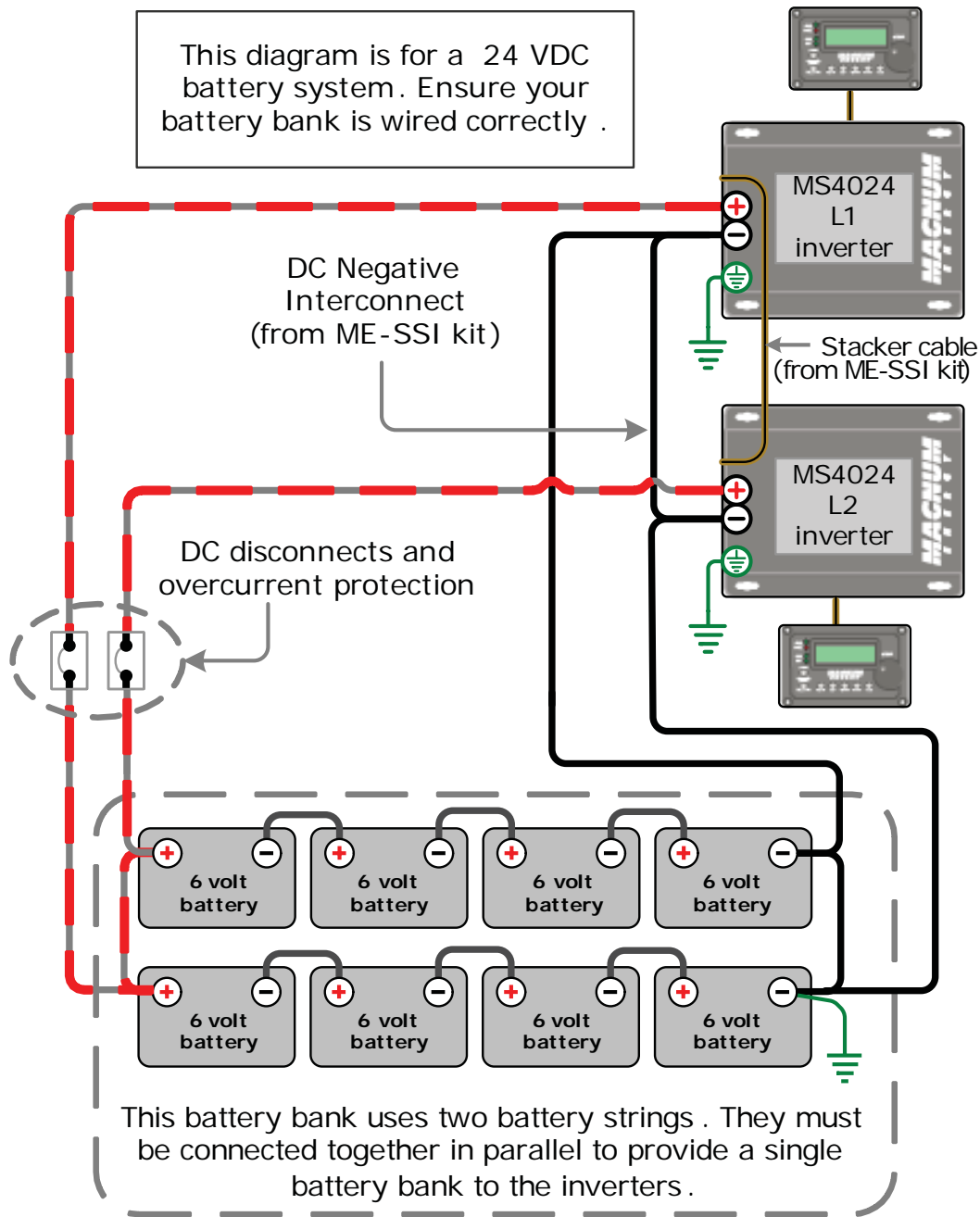




**Figure 3, DC Wiring Using One Battery Cable Pair**

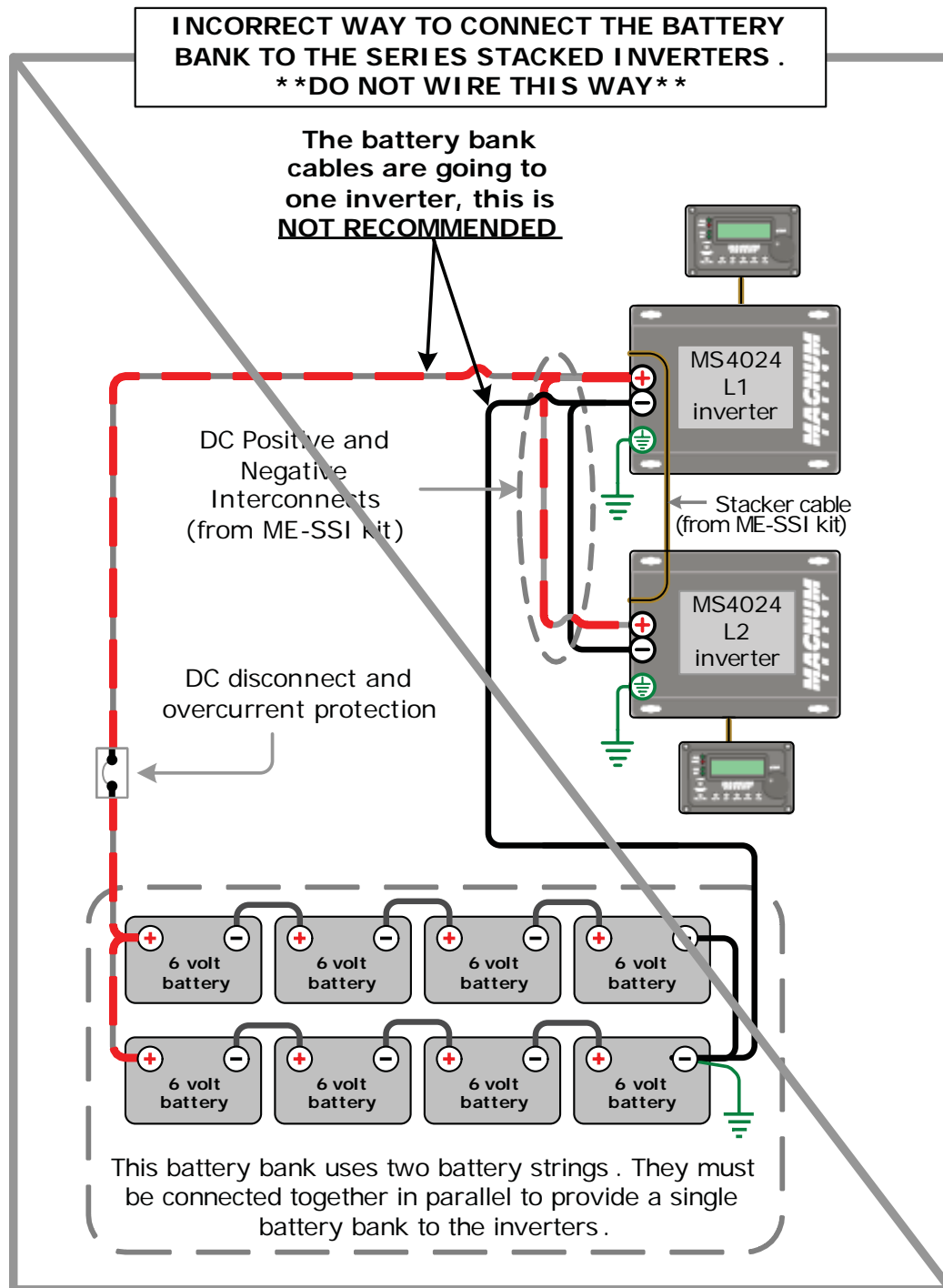
- DC Wiring Using One Battery Cable Pair** – Both inverters share a single battery cable pair (one positive and negative). It is divided between the two inverters and is protected by a single DC disconnect/overcurrent device. The positive battery cable is connected to the positive terminal of one inverter and the negative battery cable is connected to the negative terminal of the other inverter. This is to ensure an even charge and discharge through the batteries. The positive and negative interconnect cables provided are used to place the inverters as close to each other as possible.

## Installation



**Figure 4, DC Wiring Using Two Battery Cable Pairs**

- **DC Wiring Using Two Battery Cable Pairs** – Each inverter has its own battery cable pair (positive and negative for each inverter) connected to the battery bank. There are two DC disconnect/overcurrent devices, one for each positive battery cable. Use only the DC negative interconnect cables from the ME-SSI kit between the two inverters in this configuration. The positive interconnect cable is not used in this installation as it may not meet electrical code requirements, and would cause performance issues if only one DC disconnect/overcurrent device inadvertently opens.



**Figure 5, Incorrect DC Wiring**

- Incorrect DC wiring** – As shown in Figure 5, do not attempt to connect the positive and negative to one inverter and then jumper the negative and positive to the second inverter. This will not distribute the current into and out of the battery bank evenly and may not allow the second inverter to receive sufficient current if powering a heavy load. If you have a single battery cable pair, use Figure 3 to guide you in wiring your DC battery cables to the stacked pair of inverters.

## Installation

### The Stacker Cable

The stacker cable provided in the ME-SSI kit is specifically designed for series stacking two MS4024 model inverters. It allows information exchange between the two stacked inverters for two main purposes: to provide synchronization information while inverting, and to send a shut down command if a fault condition is detected. This shut down command prevents any 240VAC load from receiving only 120VAC power.



**CAUTION:** Do not use a standard telephone or data cable in place of the stacker cable or damage may occur.



**Info:** The stacker cable doesn't allow programming or access to the display from one inverter to the other. If changes or monitoring are necessary, a remote control must be connected to the affected inverter. It is highly recommended that you use two remotes in order to monitor and set each inverter.

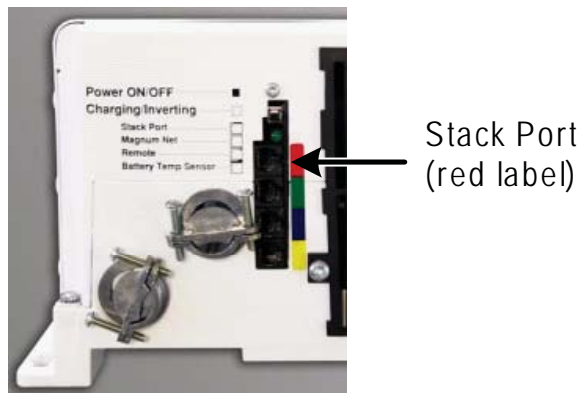
### Connecting the Series Stacker Cable

The stacker cable is a 48-inch, six-wire, twisted pair cable easily identified with a red "STACKER" label on each end. This cable also has two RJ11 connectors on each end, which allows an easy connection to the Stack Port on each inverter. Once the inverters are connected as described in the DC Wiring section, the stacker cable can be installed as follows:



**CAUTION:** Ensure that no DC power is connected to the inverter, and that the DC disconnect is open.

1. Locate the Stack Port on each inverter (see Figure 6).
2. Connect the series stacker cable from the Stack Port jack on one inverter to the Stack Port jack on the other unit.
3. Once the series stacker cable is connected gently pull on the cable at both ends, close to where they are plugged in, to ensure both connectors are secured in place.



**Figure 6, Stack Port Location (on MS4024)**

## AC Wiring

This section will discuss AC wiring that is unique to series stacking; otherwise, refer to your inverter's owner's manual for any other information on AC wiring. When wiring the AC to your series stacked inverters there are many variables that must be considered for a safe and trouble-free installation. The following options should be determined prior to any AC wiring:



**Info:** The AC source must be connected to both inverters. An AC source connected to only one inverter in a series stacked configuration is not supported and will not work.

**AC Input Source** – When an AC source is connected to the inverter's input and passing thru both inverters (Charge mode), the AC output of the two series stacked inverters is determined by the phase and voltage of the incoming AC source (utility or generator). The series stacked inverters can be operated from the following types of 120VAC/60Hz AC sources:

- **Split-phase (120/240VAC)** – This AC type provides both 120 and 240VAC. It has two 120VAC lines (L1 and L2), a neutral and a ground. The two 120VAC lines are 180° out-of-phase with each other, so that the combination of the L1 and L2 lines total 240VAC and the voltage between either L1 or L2 and neutral is 120VAC. When split-phase power is connected to the HOT 1 IN of each inverter (L1 to one inverter and L2 to the other inverter) and passing through the inverters, the incoming power is shared with the charger and the HOT 1 OUT lines continue to be 180° out-of-phase. This source is the ideal type as it will be able to provide 120/240VAC to power loads when inverting and also in Charge/Transfer mode. See Figures 7 and 9.
- **Single-phase (120VAC only)** – This AC source has one 120VAC line, one neutral, and a ground. The 120VAC line is fed to both the HOT 1 IN's of each inverter and when in Charge mode, it will pass thru to the HOT 1 OUT's of each inverter. The incoming power is shared with the charger, but since the two lines come from the same source (unlike the split-phase type), the two lines are in-phase and the voltage between the HOT 1 OUT lines will be zero. While this AC source is used to charge your batteries, you must remember that you will not be able to power any 240VAC loads (voltage from L1 to L2 will be zero). Once the AC source is disconnected and the inverters again start inverting, you can reconnect your 240VAC loads. See Figures 8 and 10.
- **Three-phase (with neutral)** – This AC source typically has three 120VAC lines, a neutral and a ground. The output of each line is 120° out-of-phase from each other, so the voltage from one line to another is 208VAC and the voltage between

## Installation

each line and neutral is 120VAC. When three-phase power is connected to the HOT 1 IN of each inverter (one line to one inverter and a different line to the other inverter) and passing through the inverter (Charge mode), the incoming power is shared with the charger. The voltage between each HOT 1 OUT and neutral will be 120VAC, and between the inverters two HOT 1 OUT lines it will be 208VAC. If this AC source is used, you must remember that you may not be able to power any 240VAC loads (voltage from L1 to L2 will be 208VAC) until the AC is disconnected and the inverters again start inverting.

- **240VAC only** – The input of the series stacked system requires either 120VAC (from hot to neutral) or 120/240VAC (with a common center “neutral” provided between the L1 and L2 lines). If a 240VAC only AC source is connected to the AC HOT input on the two inverters without a center neutral, the inverters will not recognize the AC source nor allow charging. If this AC source is required, an auto-transformer may be used to obtain a center neutral to allow charging/pass-through.



**WARNING:** The output of the series stacked inverters is 120/240VAC when inverting; however, while in Charge mode (AC is connected and charging/pass-thru), the AC output voltage is determined by the input AC voltage. Be aware that this voltage may be different from the inverting voltage and the connected load may not work or could be possibly damaged.

**AC Input** – Each inverter requires a two-conductor (hot and neutral) plus ground cable, with the hot conductor fed by a circuit breaker. If you decide to use the Single In/Single Out (30A) connection (see Figures 7 and 8), each inverter would require a 120VAC hot conductor (protected by a maximum 30A circuit breaker) connected to the HOT 1 IN terminal. The neutral conductor, which must be sized to handle the total current capacity of the HOT 1 IN conductor, must be connected to the NEUT IN terminal and a ground conductor connected to the AC ground terminal on each inverter.

For a Single In/Single Out (60A) connection (see Figures 9 and 10), each inverter would require a 120VAC hot conductor (protected by a maximum 60A circuit breaker) connected to the HOT 1 IN terminal and this connection jumpered to the HOT 2 IN terminal. The neutral conductor (which must be sized to handle the total current capacity of the HOT 1 IN conductor) must be connected to the NEUT IN terminal, and a ground conductor must be connected to the AC ground terminal on each inverter.

In most applications, these input conductors originate from an AC distribution panel, providing a main disconnect and circuit breakers required for each conductor connected to the HOT 1 IN input

on each inverter. This panel, referred to as the “main panel,” also provides the neutral and ground bus for connecting the neutral and ground conductors to the inverter.

**AC Output** – The AC output from each inverter when series stacked is 120VAC from HOT OUT to NEUT OUT. The inverters can be wired as a HOT 1 OUT only or HOT OUT 1 and HOT OUT 2 connected together by a jumper – depending on your pass-thru current requirements. One inverter is wired to provide one 120VAC output (L1) and the other inverter is wired to provide the second 120VAC output (L2). These L1 and L2 outputs are 180° out-of-phase, so the combination of the two out-of-phase 120VAC outputs will provide 240VAC.

The HOT OUT outputs of each inverter require a two-conductor (hot and neutral) plus ground cable connected to a 120/240VAC split-phase distribution panel for the loads. The panel, referred to as the “sub-panel”, must be equipped with a 240VAC double-pole circuit breaker rated at 30 or 60 amps maximum depending on which Single In/Single Out configuration you are using. The inverters output should be wired to this circuit breaker and will be used as the sub-panel main disconnect. The sub-panel then provides circuit breakers for the 120VAC and 240VAC branch circuits powering the loads.

**AC Terminal Block** – When wiring to the inverter’s six-pole AC terminal block as a series stacked pair, four different wiring configurations can be used. These different wiring configurations depend on whether the output of your AC source can provide up to 30 or 60 amps, and whether you are using a split-phase (120/240 VAC) AC source or a 120VAC only source. If only wiring to the HOT 1 (Single In/Single Out @ 30 amps), it means you have up to 30 amps pass-thru and share the incoming power with the charger. Wiring to the HOT 1 input with a jumper to the HOT 2 input (Single In/Single Out @ 60 amps) provides up to 30 amps pass-thru on each input (60 amps total).



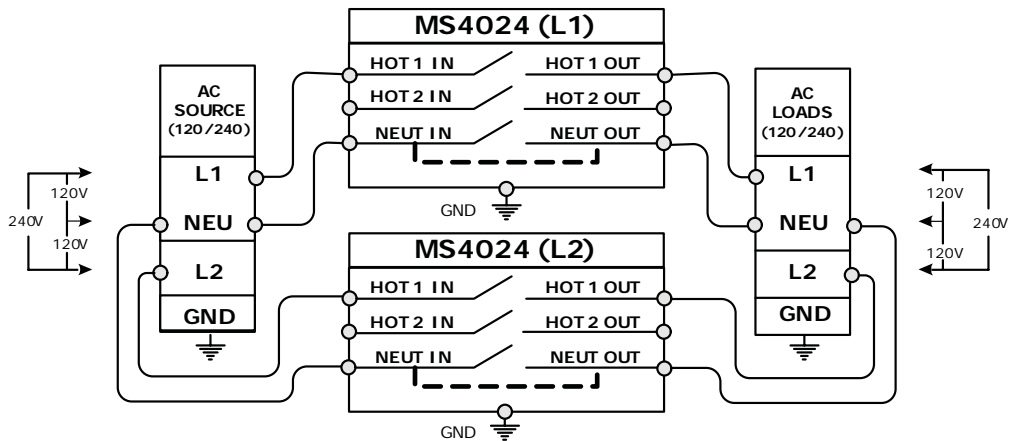
**Info:** The Dual In/Dual Out wiring configuration is not recommended with a series stacked system, as they would conflict with one another.



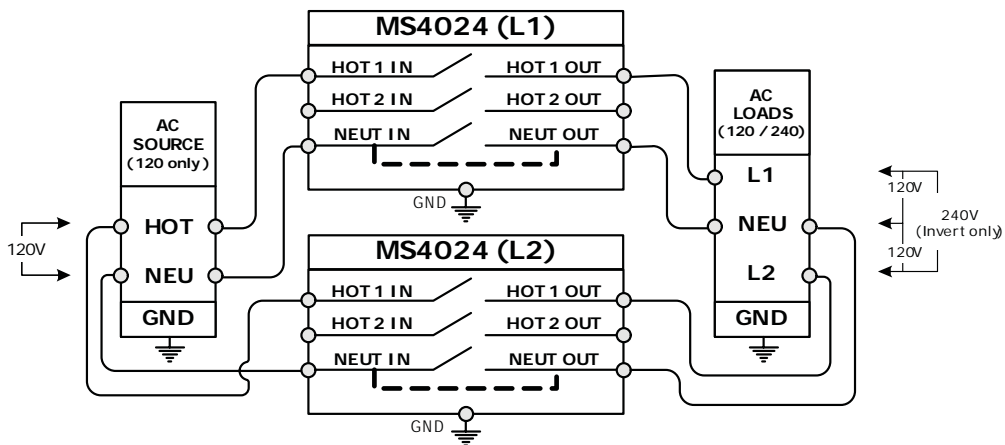
## Installation

### Determine Which AC Wiring Configuration to Use:

**Single In/Single Out (30 Amps)** – Using a single line (HOT 1) for the input and output provides up to 30 amps AC pass-thru and shares power with the charger. Use this configuration if your AC source is 30 amps or less. See Figures 7 and 8 below.

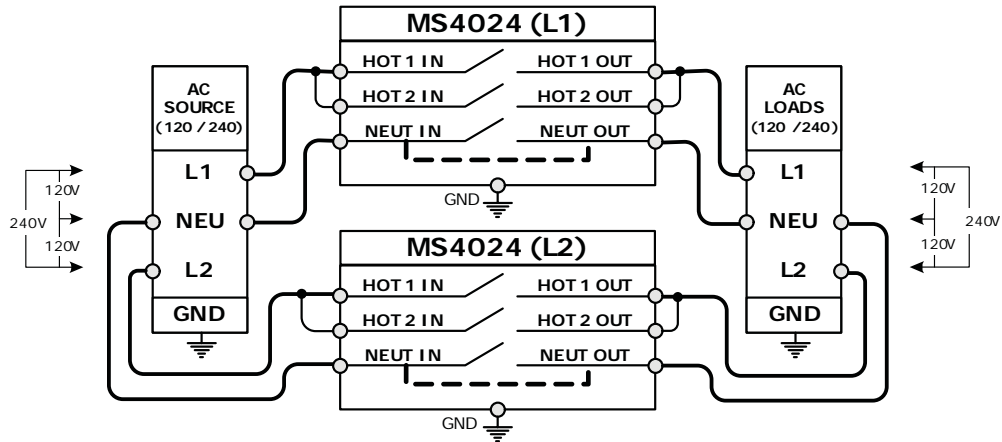


*Figure 7, Single In/Out (30A with 120/240VAC source)*

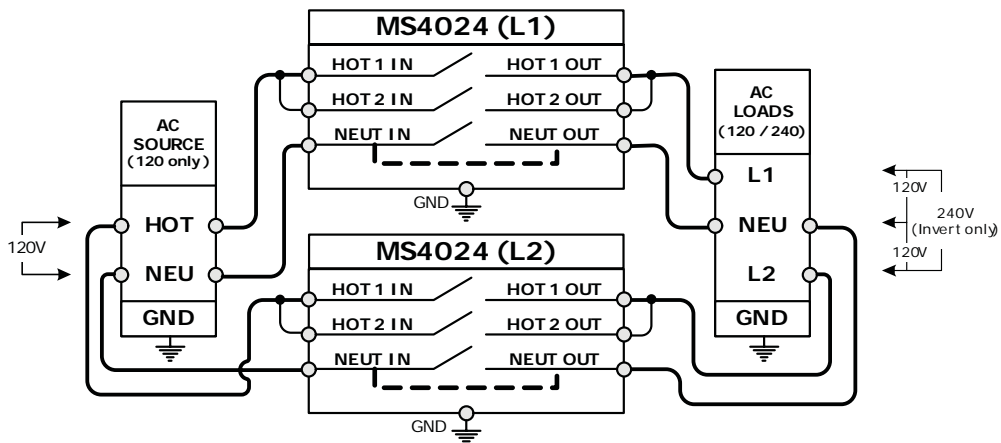


*Figure 8, Single In/Out (30A w/ 120VAC only source)*

**Single In/Single Out (60 Amps)** – Using both inputs (HOT 1 and HOT 2) for the input and output provides up to 60 amps AC pass-thru (30 amps each line). The HOT 1 line passes through the unit and also shares power with the charger. The HOT 2 line passes through the unit without sharing power with the charger. Use this configuration if the output from your AC source provides more than 30 amps. See Figures 9 and 10 below.



**Figure 9, Single In/Out (60A with 120/240VAC source)**



**Figure 10, Single In/Out (60A w/ 120VAC source only)**



**Info:** The dashed lines between the NEUT IN and NEUT OUT in Figures 7 through 10 represent the RD and MS-AE Series models. Those models have no internal relay between the NEUT IN and NEUT OUT, as they are tied together.



**Info:** Refer to the MS4024 Owner's Manual for information on how to connect the AC terminal.

## Installation

### Neutral to Safety Ground Bonding

Electrical safety standards for wiring mobile (RV, boat, or truck) and AE (houses, cabin, or office) installations require: an AC source such as the utility feed in your home, an inverter or a generator, and the neutral conductor tied to ground. These standards also require that the AC neutral be connected to safety ground (often called a “bond”) in only one place at any time (often called a “bond”). If more than one bond is established, currents can circulate between neutral and ground and cause ground-loop currents. These “ground-loops” can trip GFCIs and cause an electric shock hazard.

The fundamental difference between using an inverter in a mobile installation as opposed to an AE installation is how the neutral is grounded in the AC system. There may be multiple AC sources in mobile installations, which means there is the potential of having multiple neutral to ground connections. Therefore, if you are using an inverter as one of your AC sources along with another AC source (i.e., utility power or generator), you must ensure that the inverter does not also connect the neutral to ground while the other AC source is actively powering the inverter loads. In AE installations, the main service panel provides the neutral to ground bond for the entire electrical system – not in the inverter.

The MS4024 inverter provides an internal relay that connects the neutral to ground while inverting and opens this neutral-to-ground connection automatically when connected to an active AC source, such as utility power or a generator.



**WARNING:** Each MS4024 inverter in a series stacked configuration provides a neutral-to-ground connection, creating two “bonds” at the same time. Depending on the installation, either one or both of the neutral-to-ground connections inside the inverter must be disconnected to prevent multiple neutral to ground connections.

In a mobile installation, the neutral-to-ground connection in one of the MS4024 inverters in a series stacked configuration must be disconnected; while leaving the neutral-to-ground connection in place in the other MS4024 inverter to allow the automatic neutral-to-ground switching to continue for the series stacked pair.

In an AE installation, the neutral-to-ground connection in both of the MS4024 inverters must be disconnected, because the neutral-to-ground connection is provided in the main AC panel.



**WARNING:** Any neutral-to-ground bond downstream from the inverter must be removed to prevent multiple bonds. If there is an inverter sub-panel — separate from a “main” electrical panel — it should have a removable wire that allows the neutral bus to be unbonded from the ground bus.

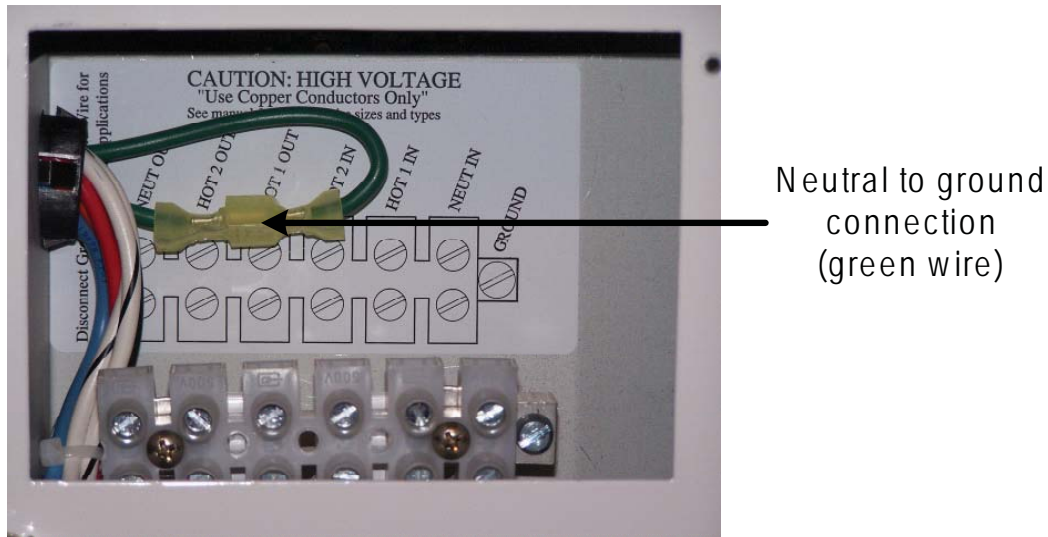
### Disconnecting the Neutral-to-Ground Connection

The following instructions will guide you in disconnecting the neutral-to-ground connection.



**WARNING:** Fire and Shock Hazard – Disconnect all AC and DC sources before working with AC wiring.

1. Locate and remove the inverter's AC access cover plate.
2. At the top of the AC wiring compartment, locate the green wire with the insulated connector (see Figure 11). This connects the neutral and ground inside the inverter.
3. Pull the two ends of the insulated connector apart to separate the green wire. This prevents a neutral/ground connection.
4. Move the two disconnected ends away from each other and push them back out of the way. The two connector ends shouldn't have any contact with any other wires within the compartment. Use electrical tape to insulate the ends.



**Figure 11, AC Wiring Compartment (MS4024 model)**

### Grounding

Ensure all components are grounded properly for safety and code-compliance. Refer to your inverter's owner's manual for specific grounding information on your inverter.



**WARNING:** When stacking inverters, ensure the chassis of each inverter is connected to the same common ground (i.e., in the utility or inverter panel); otherwise, a hazardous voltage difference may be present between them.

The installation is complete, follow the information provided in the Operation section to test and operate the series stacked system.

### Operation

When two inverters are series stacked and inverting, they coordinate with each other to ensure the output can power 240VAC loads. This requires that the inverters turn on together and switch to the AC source at the same time; and, both inverters should shut down if either one becomes inoperable. This Operation section provides a functional test to ensure the two inverters are working together as a series stacked pair, and also provides information pertinent to the set-up and operation of a series stacked configuration.

#### Using the Remote Control

The default settings in your inverter are adequate for most installations; however, in a series stacked configuration we highly recommend using the ME-RC50 or ME-ARC50 remote controls. These remote controls can be used to monitor the inverter's status and make set-up changes. A single remote can be used to configure each inverter, but not at the same time. If you want the ability to monitor and configure both units at the same time, each inverter will require its own remote.



**Info:** To use a remote control, it must have revision 1.2 or higher to work properly with a series stacked configuration.

#### Functional Test

Series stacked inverters must communicate together to provide 120/240VAC to the loads and shut down if any inverter faults occur. This functional test will confirm the two units are operating correctly as a series stacked pair. Before performing the functional test, ensure the following:

- All DC disconnects to the inverters are turned off.
- All AC input and output circuit breakers are turned off.
- Only the stacker cable provided in the ME-SSI is used.
- The stacker cable is connected to each inverter's Stack Port (red label).
- Only MS4024 inverter models are stacked together.
- NEUT OUT of both inverters are connected to the same neutral bus.
- DC and AC grounds are both connected and properly installed.
- AC input connections and AC output connections are wired correctly on the terminal block and not reversed (double-check before turn-on).
- All DC connections are properly connected and tight.

- Battery voltage is within the DC voltage range for your inverter.
- The DC negatives of each inverter are connected together using the negative DC interconnect provided (i.e., 2/0 AWG and 3 feet max).
- The positive (+) battery cable(s) is connected to the positive (+) battery terminal through a DC disconnect and overcurrent device.
- The negative (-) battery cable(s) is connected to the negative (-) battery terminal.

### Power-up Sync Test

1. While monitoring the Status LED located on each inverter, apply DC voltage to both inverters at the same time (ensure AC is not connected).



**CAUTION:** It is crucial that the DC voltage be connected to both inverters within 15 seconds of each other. The units go through an auto-detect when first powered-up to synchronize the units for series stacking. If both units are not powered up within this time, then series synchronization will not occur.

2. The Status LED on both inverters should blink 9 times in sync. This indicates that the two units have recognized each other and are communicating as a series stacked system.

### Testing Invert Mode

3. Press the Power ON/OFF switch on either inverter, this should turn on both inverters. (If using a remote control, press the INVERTER ON/OFF button on either remote, and then verify that the INV and PWR LED on both remotes come on). If either unit is "Searching", you must disable the Search mode prior to making any voltage measurement. The inverters should now be providing 120/240VAC to the AC sub-panel.
4. Measure the voltage between the L1 terminal and the neutral bus in the AC sub-panel. This voltage should be 120VAC ( $\pm 6$ VAC).
5. Measure the voltage between the L2 terminal and the neutral bus in the AC sub-panel. This voltage should be 120VAC ( $\pm 6$ VAC).
6. Measure the voltage between the L1 and L2 terminals in the AC sub-panel. This voltage should be 240VAC ( $\pm 12$ VAC).
7. Turn on the AC load breakers in the sub-panel which are powered by the inverters.

## Operation

8. Turn on a 120VAC load powered by the inverter feeding the L1 terminal and verify that it works. Turn on a 120VAC load powered by the other inverter which feeds the L2 terminal and verify that both of these loads work. Turn on a 240VAC load powered by the hot outputs of both inverters and verify that it works correctly – leave all these loads on.

### Testing AC Transfer/Charge Mode

9. Check the AC transfer. Apply AC power to both inverters, after a few seconds:
  - a. If using the remote control – wait till the CHG LED on the remote control for both units stops blinking and comes on solid. Press the INVERTER ON/OFF button to disable the Inverter mode and verify the INV LED turns off, and that the loads connected in Step 8 continue to work.
  - b. Without the remote control – the Status LED on both inverters will come on. Press the inverter's Power ON/OFF switch and verify that the loads connected in Step 8 continue to work.
10. Check the Charge mode. Verify the batteries are being charged – may take minutes before the charge current is actually seen.
  - a. If using the remote control – monitor the CHG LED on the remote, if it is blinking on either remote, press the CHARGER ON/ OFF button on that remote to turn the charger on. Verify the CHG LED on both remotes are on solid (not blinking) and the remote display shows that they are both in Charge mode (i.e., “Bulk Charging”, “Absorb Charging”, etc.).
  - b. Without the remote control - the Status LED on both inverters will come on (the LED will be on solid or blink depending on the Charge mode).

This completes the functional test. If the inverters are functioning correctly as a series stacked pair, continue to the Inverter and Charger Operation sections. If any step did not operate correctly, refer to the Troubleshooting section in this manual or in the owner's manual for your inverter.



## Inverter Operation

**Invert Mode** - The units are turned on by pressing the Power ON/OFF switch on either inverter. Alternatively, they can also be started by pressing the INVERTER ON/OFF button on a remote control connected to either inverter. When the two inverters are inverting, they communicate over the Stacker cable. This cable communicates to monitor the AC output from each inverter and shift it 180° out of phase from each other to provide 240VAC on both units, and to verify that there are no faults on either unit to prevent only one unit from inverting. The two units also use the DC negatives as a reference point while they are communicating; hence, the reason why the DC negatives must be tied together – to ensure there is no negative voltage difference between the two units.

**Inverter settings** - When the units are inverting as a series stacked configuration, certain settings must be coordinated in each unit for proper operation. Without a remote control, the default settings on each unit will be coordinated. If using a remote control, check that the following settings are the same between the two units:

1. Ensure the *Adj LowBatCutOut* setting is the same for both units.
2. If the Search mode is needed, then set the *Adj Search Watts* setting for each inverter to determine when to start powering 120VAC loads. The two inverters are independent, which means one inverter can come out of Search mode and start inverting, while the other unit continues in the Search mode until a load exceeds the search watts threshold of that unit. If powering 240VAC loads, then the search watts sensibility is determined by combining the 'Search Watts' setting on both units.

**For example:** Given a 15 watt *Search Watts* setting on the L1 inverter and a 10 watt *Search Watts* setting on the L2 inverter, and a 20 watt/120VAC load on the L1 inverter and no load on the L2 inverter. This would cause the L1 inverter to start inverting, but the L2 inverter would continue in Search mode. With the same *Search Watts* settings, a 25 watt/240VAC or greater load would cause both the L1 and L2 inverters to come on and start inverting.

## Charger Operation

**Charge Mode** – The series stacked configuration is designed to accept 120VAC to each inverter, typically from a split-phase, 3 wire 120/240VAC power source. The HOT IN terminals of each inverter accepts one line of 120VAC each and the NEUT IN terminals of both inverters are tied together and connected to the AC power source neutral line. When the AC line voltage and frequency are good to both units, they both transfer and go to Charge mode and begin charging – if enabled. However, it is not necessary for either unit to have charging enabled for the pair to operate.

## Operation

After the series stacked pair is in Charge mode, the remote will show “Charging” and begin to sample the battery voltage. If the voltage is 26.0 or above, the units will go into “Float Charging” mode. If the battery voltage is below 26.0, they will go into “Bulk Charging” mode. It is possible that if the battery voltage is close to the 25.8-26.0V threshold, one charger may go to float while the other may go to Bulk Charge mode.

The stacked pair of chargers work independently of each other, and because of this, there can be some voltage regulation interactions. To handle this, the charge voltage regulation routine while stacked will sample twice as much as usual. This may mean that the chargers may take a minute or two before charge current is actually seen, once AC input is first applied. Once charging has started — because they are independent chargers — they may not share the charge current evenly, but will individually provide current to the batteries up to their maximum current rating, which is the maximum *Charge Amps* or *Input/Shore Amps* setting, whichever is less. Any power required for battery charging will be in addition to any AC loads being powered while AC input is present to the inverters.



**Info:** During Bulk Charging, both inverters will attempt to balance the total current provided to the batteries. During Absorption or Float Charging the current will differ.

While in Charge mode, if either unit senses a loss of AC input power, both units will transfer from Charge to Inverter mode. Once this transfer is made, 120VAC is available from each individual inverter and 240VAC is available across the HOT OUT terminals of the stacked pair.

**Charger settings** – If a remote control is used, care should be taken to insure that battery charger settings are the same for both inverter chargers. Without a remote control, the default settings on each unit will be coordinated. If you are using a remote control, then check that the *Adj Charge Rate*, *Adj Batt AmpHrs*, *Adj Battery Type*, and *Adj VAC Dropout* settings on the two units are the same.

**Charging with a generator** – If you manually start a generator and use it as the AC source to charge the inverter batteries, you should be aware that because both inverters will be charging the same battery, one may taper off first and finish the Bulk Charge stage before the other. When one inverter has reached the Float Charge stage (after both units were charging in the Bulk Charge stage), then it is best to turn off the generator; running a generator to only float charge your batteries is very inefficient and if possible, should be avoided.

## Troubleshooting

### Inverter Faults

Both units will shut down if either has an auto-resetting fault condition (such as high battery, low battery, or over-temperature). Both inverters will automatically come back on when the fault condition has been cleared.

If one or both units experience any of the manual reset fault conditions, like a continuous AC overload or internal faults, both units will shut down. These types of faults require a manual reset by pushing one of the inverters' Power ON/OFF switch (or by pressing the INVERTER ON/OFF switch on the remote control if available). If there are remote controls used in the system, the inverter/remote combination with the fault will display the actual fault while the other inverter will display "Stack Mode Fault", which means the other unit has the fault.

### Stacking Faults



**Info:** Having a remote for each inverter (two remotes) makes it easier to troubleshoot stacking faults.

In a series stacked configuration, your remote may display a fault condition not possible on a single inverter installation:

#### Stack Mode Fault

There is a problem with the "other" inverter. Check the remote display of the other unit to determine the fault condition that must be cleared.

#### StackClock Fault

There is a stacker cable problem; or, one inverter is losing synchronization with the other inverter.

#### StackPhase Fault

There is a problem with the AC input wiring; or, one phase was lost from the AC input source; or, one of the inverter's internal transfer relay is bad; or, the inverter's AC input circuit breaker may be open.

### Troubleshooting Tips

If there is no 240VAC output, ensure that the Status LEDs on both inverters blink in synchronization (the sync detection blinks 9 times total) when DC power is first connected. This is a stacker test and signifies that both units have autoconfigured for Stacker mode. The DC voltage must be connected to both inverters within 15 seconds of each other.

If both units are in Inverter mode and then shut down, inspect the stacker cable and reconnect at both ends, ensuring an audible "click" at both inverters. Try to watch when the shutdown happens to determine the fault. If a remote control is available, monitor its display to reveal which fault is happening.

### Warranty/Service Information

#### 24 Month Limited Warranty

Magnum Energy, Inc., warrants this ME-SSI to be free from defects in material and workmanship that result in product failure during normal usage, according to the following terms and conditions:

1. The limited warranty for the product extends for 24 months beginning from the product's original date of purchase.
2. The limited warranty extends to the original purchaser of the product and is not assignable or transferable to any subsequent purchaser.
3. During the limited warranty period, Magnum Energy will repair or replace (with factory new or remanufactured replacement items) at Magnum Energy's option any defective parts, or any parts that will not properly operate for their intended use – if such repair or replacement is needed because of product malfunction or failure during normal usage. The limited warranty does not cover defects in appearance (cosmetic or decorative), or any structural or non-operative parts. Magnum Energy's limit of liability under the limited warranty shall be the actual cash value of the product at the time the original purchaser returns the product for repair, determined by the price paid by the original purchaser. Magnum Energy shall not be liable for any other losses or damages.
4. Upon request from Magnum Energy, the original purchaser must prove the product's original date of purchase by a dated bill of sale, itemized receipt.
5. The original purchaser shall return the product prepaid to Magnum Energy in Everett, WA. After the completion of service under this limited warranty, Magnum Energy will return the product prepaid to the original purchaser via a Magnum selected non-expedited surface freight within the contiguous United States and Canada; this excludes Alaska and Hawaii.
6. If Magnum repairs or replaces a product, its warranty continues for the remaining portion of the original warranty period or 90 days from the date of the return shipment to the original purchaser, whichever is greater. All replaced products and parts removed from repaired products become the property of Magnum Energy.
7. This limited warranty is voided if:
  - the product has been modified without authorization
  - the serial number has been altered or removed
  - the product has been damaged through abuse, neglect accident, high voltage, or corrosion
  - the product was not installed and operated according to the owner's manual

**BEFORE RETURNING ANY UNIT, CONTACT MAGNUM ENERGY FOR A RETURN MATERIAL AUTHORIZATION (RMA) NUMBER.**

### How to Receive Repair Service

If your Product requires warranty service or repair, contact either:

1. An Authorized Service Center, which are listed on the Magnum Energy Website at <http://www.magnumenergy.com/ServiceCenters.htm>.
2. Magnum Energy, Inc. at:
  - Telephone: 425-353-8833
  - Fax: 425-353-8390
  - Email: [warranty@magnumenergy.com](mailto:warranty@magnumenergy.com)

If returning your Product directly to Magnum Energy for repair, you must:

- return the unit in the original, or equivalent, shipping container
- receive a Return Materials Authorization (RMA) number from the factory prior to the return of the Product to Magnum Energy for repair
- place RMA numbers clearly on the shipping container or on the packing slip

When sending your Product for service, please ensure it is properly packaged. Damage due to inadequate packaging is not covered under warranty. We recommend sending the Product by traceable or insured service.

---

**MAGNUM**  
E N E R G Y