

ME-BMK | BATTERY MONITOR KIT

Introduction

Monitoring your battery bank is easy with the Battery Monitor Kit (ME-BMK).* Acting as a “fuel gauge” for your batteries, the ME-BMK monitors their state of charge (SOC) and then provides this information in an easy-to-understand display via the ME-ARC or ME-RC remotes. With accurate SOC readings, you can avoid unnecessary battery recharging, saving on fuel and long-term maintenance costs.

If you already have a Magnum Energy brand Inverter/Charger and Remote,* the ME-BMK is an easy retrofit. Simply install the kit according to the installation manual and begin monitoring your battery bank via the “Meter” button on your ME-ARC/ME-RC.



Features

Available Readings from the ME-BMK / ME-BMK-NS:

- State of Charge (SOC) 0 - 100%
- DC volts
- DC amps
- Amp hours in/out
- Resettable amp hours out
- Total amp hours out
- Minimum volts DC
- Maximum volts DC
- Temperature compensated
- Auto detects input voltage

Kit Includes

- Sense module
- DC shunt 50mv/500 amp shunt (not included in the ME-BMK-NS kit)
- Twisted pair wire 5' length, 18 AWG wire
- Communication cable 10' length, 4-conductor, telephone standard

Model Numbers

- ME-BMK
- ME-BMK-NS (no shunt)

Available For

- Renewable Energy Systems
 - Off-grid Power
 - Back-up Power
- Marine Systems
- RV Systems

Works With

- ME Series
- MM-AE Series
- MS Series
- MS-PAE Series
- RD Series

*The ME-BMK or ME-BMK-NS require a Magnum inverter to communicate with the connected remote (ME-ARC/ME-RC).



SPECIFICATIONS

BATTERY MONITOR KIT SPECIFICATIONS	
DC volts	7 to 70 ($\pm 0.5\%$) auto voltage detection
DC amps	± 0.1 to 999 ($\pm 1.0\%$)
Battery SOC %	0 to 100% (1% increments)
Power draw	< .6 watts
Amp hours in/out	$\pm 32,768$ amp hours (1 AH increments)
rAH out (resettable amp hours removed)	0 to 65,535 amp hours, resettable (0.1 AH increments)
tAH out (total amp hours removed)	0 to 65,535,000 amp hours (0.1 k or 100 AH increments)
Minimum/maximim DCV Display	7 to 70 VDC, resettable
Shipping weight	2 lb (.9 kg)
Kit includes	Manual, sense module, DC shunt, twisted pair wire, and communication cable
Sense wire	Twisted pair –blue & orange, 5' length, 18 AWG wire
Communication cable	4-conductor, 10' twisted pair, telephone standard
Remote requirements	Use with an ME-RC with firmware revision of 2.0 or higher or an ME-ARC (all revisions)
DC SHUNT (NOT INCLUDED WITH THE ME-BMK-NS KIT)	
Resistance	0.1 milliohm (500A at 50mV)
Continuous current	410 amperes maximum
Overload current	Overloads to 500 amps for less than 5 minutes if normally operated at less than 300 amps



BASIC CONFIGURATION DIAGRAM

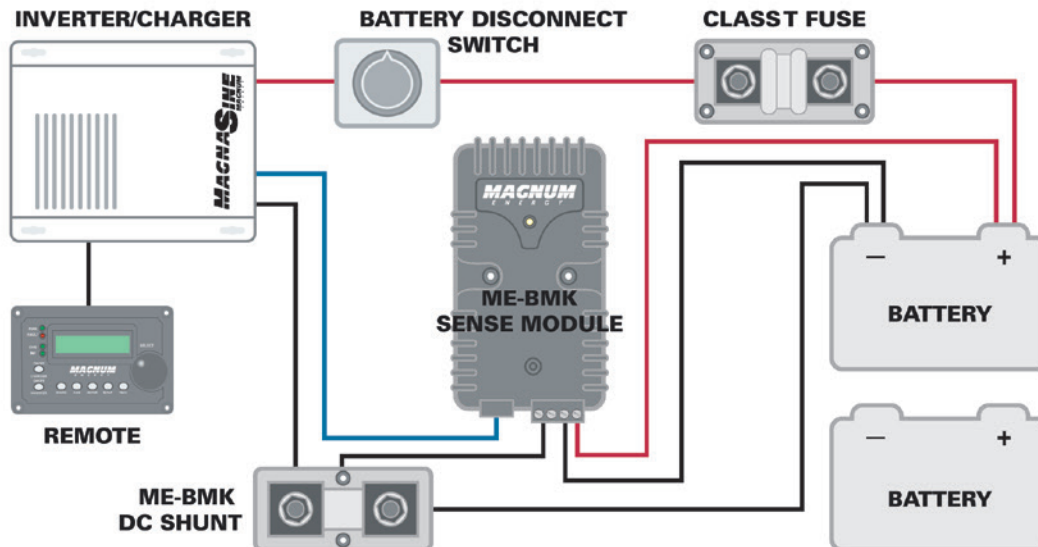

GENERAL NOTES

* Requires remote revision 2.0 or higher.
 Testing for specifications at 25° C.
 Specifications subject to change without notice.

Sensata Technologies, Inc. ("Sensata") data sheets are solely intended to assist designers ("Buyers") who are developing systems that incorporate Sensata products (also referred to herein as "components"). Buyer understands and agrees that Buyer remains responsible for using its independent analysis, evaluation and judgment in designing Buyer's systems and products. Sensata data sheets have been created using standard laboratory conditions and engineering practices. Sensata has not conducted any testing other than that specifically described in the published documentation for a particular data sheet. Sensata may make corrections, enhancements, improvements and other changes to its data sheets or components without notice.

Buyers are authorized to use Sensata data sheets with the Sensata component(s) identified in each particular data sheet. HOWEVER, NO OTHER LICENSE, EXPRESS OR IMPLIED, BY ESTOPPEL OR OTHERWISE TO ANY OTHER SENSATA INTELLECTUAL PROPERTY RIGHT, AND NO LICENSE TO ANY THIRD PARTY TECHNOLOGY OR INTELLECTUAL PROPERTY RIGHT, IS GRANTED HEREIN. SENSATA DATA SHEETS ARE PROVIDED "AS IS". SENSATA MAKES NO WARRANTIES OR REPRESENTATIONS WITH REGARD TO THE DATA SHEETS OR USE OF THE DATA SHEETS, EXPRESS, IMPLIED OR STATUTORY, INCLUDING ACCURACY OR COMPLETENESS. SENSATA DISCLAIMS ANY WARRANTY OF TITLE AND ANY IMPLIED WARRANTIES OF MERCHANTABILITY, FITNESS FOR A PARTICULAR PURPOSE, QUIET ENJOYMENT, QUIET POSSESSION, AND NON-INFRINGEMENT OF ANY THIRD PARTY INTELLECTUAL PROPERTY RIGHTS WITH REGARD TO SENSATA DATA SHEETS OR USE THEREOF.

All products are sold subject to Sensata's terms and conditions of sale supplied at www.sensata.com SENSATA ASSUMES NO LIABILITY FOR APPLICATIONS ASSISTANCE OR THE DESIGN OF BUYERS' PRODUCTS. BUYER ACKNOWLEDGES AND AGREES THAT IT IS SOLELY RESPONSIBLE FOR COMPLIANCE WITH ALL LEGAL, REGULATORY AND SAFETY-RELATED REQUIREMENTS CONCERNING ITS PRODUCTS, AND ANY USE OF SENSATA COMPONENTS IN ITS APPLICATIONS, NOTWITHSTANDING ANY APPLICATIONS-RELATED INFORMATION OR SUPPORT THAT MAY BE PROVIDED BY SENSATA.

Mailing Address: Sensata Technologies, Inc., 529 Pleasant Street, Attleboro, MA 02703, USA.