

DIMENSIONS™

DC to AC Power Inverter/Charger

24 VDC to 120 VAC

Pure Sine Wave Output

Owner's Manual



Models:

24NP36



Sensata
Technologies

TABLE OF CONTENTS

Introduction	3
Safety Information.....	4
Specifications	6
Components	7
Design Features.....	8
Installation	9
Mount the Inverter	9
Wiring Diagram.....	10
DC Wire Gauge & Fusing.....	11
AC Input & Output Connections	12
BTS Connection.....	13
Remote Operation	15
NP Control Board Pinout	17
Operation	18
Inverter Power Mode	18
External Power Mode.....	18
Operation Using 7-Segment Display	22
Operation Using Remote On/Off Switch	26
GFCI Operation	27
Optional LCD Remote	28
Configurations	29
NVM Setup Utility.....	29
Configurations	30
Ignition Switch Control with the 7-Seg Display Panel.....	32
Branch Circuit Rating (BCR) Max Limit with the 7-Seg Display Panel	33
Battery Type and Profile with the 7-Seg Display Panel.....	33
Troubleshooting	34
7-Seg Display Panel Messages.....	34
LED Status Chart	38
Troubleshooting Guide.....	40
Appendix	41
Accessories & Replacement Parts	41
System Default Settings	42
Inverter Charger Model Options.....	42
CAN	43
Limited Warranty Terms & Conditions	45

INTRODUCTION

Thank you for purchasing a Dimensions™ inverter/charger from Sensata Technologies®! We think that you will find this product to be extremely reliable and easy to use.

Please read this manual completely before installing or operating the unit.

All information is subject to change without warning.

Important Safety Information

Read this manual before installation. This manual contains important instructions pertaining to safety, installation, and operation.

Save this manual and keep it in a safe place.

Sensata Technologies is an ISO 9001:2015 Registered Company.

Sensata uses the following special notices to help prevent injury and/or damage to equipment:

Safety Symbols

- ▲ **DANGER** indicates an imminently hazardous situation which, if not avoided, will result in death or serious injury.
- ▲ **WARNING** indicates a potentially hazardous situation which, if not avoided, could result in death or serious injury.
- ▲ **CAUTION** indicates a potentially hazardous situation which, if not avoided, may result in minor or moderate injury.

CAUTION is used without the safety alert symbol indicates a potentially hazardous situation which, if not avoided, may result in property damage.

NOTE is used to notify of installation, operation, or maintenance information that is important but not hazard related.

Safety Listing



Power Inverter, E100666

Inverter Safety Instructions

- ▲ **WARNING:** Customer must match battery type with charger battery type.
- ▲ **WARNING:** Power inverters produce hazardous voltages. To avoid risk of harm or fire, the unit must be properly installed.
- ▲ **WARNING:** There are no user serviceable parts inside. Do not remove the cover.
- ▲ **WARNING:** Power inverters should not be mounted in a location that may be exposed to rain, spray, salt, or corrosive chemicals.
- ▲ **WARNING:** Power inverters should not be installed in a zero-clearance enclosure.
- ▲ **WARNING:** Damage to the power inverter will occur if correct polarity is not observed when installing the inverter's DC input cables.
- ▲ **WARNING:** Damage to the power inverter will occur if an external AC power source is applied to the inverter's AC hardwire output.
- ▲ **WARNING:** Power inverters contain a circuit breaker and capacitor that may produce a spark upon connection or during normal operation. Do not mount in a confined battery or gas compartment where toxic fuel vapor is present.
- ▲ **WARNING:** Be sure that the power inverter is turned off and AC power is disconnected when batteries are being connected, disconnected, serviced, and replaced or personal injury and/or damage to the inverter could result.
- ▲ **WARNING:** Working near lead-acid batteries is dangerous. There is a risk of acid exposure.

Battery Safety Instructions

- ▲ **WARNING:** Batteries may vent explosive gases during operation.
- ▲ **WARNING:** There is risk of high current discharge from shorting a battery that can cause fire and explosion. Use insulated tools during installation.
- ▲ **WARNING:** Remove all rings, watches, jewelry, or other conductive items before working near the batteries.
- ▲ **WARNING:** Inspect the batteries at least once a year for cracks, leaks, or swelling. Follow the scheduled maintenance procedures from the battery manufacturer.
- ▲ **WARNING:** Dispose of the batteries according to local regulations. Do not incinerate batteries; there is risk of explosion.
- ▲ **WARNING:** A fuse must be installed between the battery and the inverter to protect against shorted cables.
- ▲ **WARNING:** If multiple LFP batteries are connected in parallel, the maximum charger current shall not exceed the maximum rated charge current of a single battery. This is to prevent overcharging into one battery if any other battery disconnects during charging. Failure to limit the charge current may result in the battery disconnecting due to overcurrent and/or may damage the battery.
- ▲ **WARNING:** Only use LFP batteries that utilize a BMS that shuts down the battery due to over-current, high temperature, and cold temperature.
- ▲ **WARNING:** The converter/inverter is intended to recharge batteries. The battery that is connected to this product is only suitable if it complies with the given battery standard for that battery type and is provided with a battery management system that will monitor and control the electrical and thermal health of the battery during charging. When installing this converter/inverter, the battery is to be verified as in compliance with the applicable battery standard.

Specifications

▲ WARNING: The inverter is intended to recharge batteries. The battery that is connected to this product is only suitable if it complies with the given battery standard for that battery type and is provided with a battery management system that will monitor and control the electrical and thermal health of the battery during charging. When installing this inverter, the battery is to be verified as in compliance with the applicable battery standard.

All ratings assume 25.2 VDC nominal voltage, 25°C ambient temperature, and that the inverter is mounted in free air. Specifications are subject to change without notice.

Inverter	24NP36
Enclosure Type	Large
Output Power (Watts Cont.)	3600
Output Current (Amps AC Cont.)	30
Input Current (Amps DC Cont.)	Up to 167
Peak Power (Watts)	8000
Peak Output (Amps AC)	100
Motor Starting Rating (HP)	2
Weight (lbs.)	68
Dimensions in. (L x W x H)	13.8 x 17.1 x 8
Output Voltage (VAC)	120 +/- 3%
Output Frequency	60 +/- .05%
Output Waveform	Pure Sine < 5% THD
Input Voltage (VDC)	21–34
Nominal Input Voltage (VDC)	25.2
Operating Temperature	-20°C to 65°C (0°F to 149°F)
Peak Efficiency	Up to 88%
DC Input Capacitance	Up to 160,000µF
Battery Charger	
Minimum Req'd Battery A-Hr*	50
Max A-Hr**	500
AC Input Voltage Range (VAC)	95 –135
Nominal Input Voltage (VAC)	120
Input Current (AAC)	Up to 25
Output (ADC)	Up to 90
Bypass (AAC)	30

Table 1 Specifications

* For optimal charging, the inverter amp hour setting should match the amp hour rating of the connected battery.

** Each inverter amp-hr setting can be adjusted with the optional LCD or with RV-C CAN.

Components

Introduction

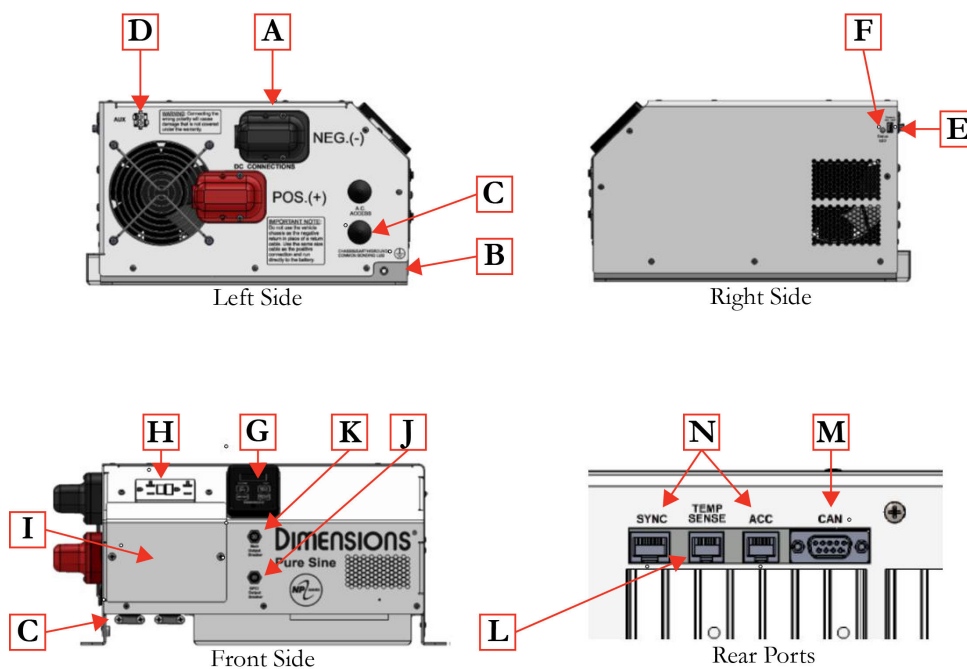

Figure 1 Components

- A. DC Input
- B. Bonding Lug
- C. AC Input & Output (Hardwired)
- D. AUX Connector
- E. Remote Switch Wiring Tab
- F. Status LED
- G. 7-Segment Display
- H. GFCI
- I. AC Wiring Plate
- J. 20 A GFCI Output Breaker
- K. 30 A Output Breaker
- L. BTS Connector Port
- M. CAN Port
- N. AUX Ports and Connectors

Design Features

- **DC Input:** Connects to the 24 VDC battery bank.
- **Bonding lug:** Connects to the system ground.
- **AC Input & Output (Hardwired):** Terminal blocks are provided behind front access cover for hardwiring AC Input and Output. A second set of openings to access the AC terminals can be found on the underside of the inverter/charger when using the large chassis.
- **AUX Connector:** Currently not used in standard configuration. Mating connector sold separately.
- **Remote Switch Wiring Tab:** Terminal is used to wire a customer supplied snap style “On/Off” switch.

NOTE: The 7-Seg display can also be used as a remote. Order remote LCD panel kit# 625000. Alternatively, the “R” suffix version of the inverter can also be provided with a simple “On/Off” switch in place of either remotes. See the “L” option in the Appendix.

- **Status LED:** This LED will show the operation mode and troubleshooting information. See the table in the troubleshooting section at the rear of the manual for further mode descriptions.
- **7-Segment Display:** Provides limited local control and status of the inverter/charger. The 7-Seg display or an LCD remote may be purchased separately as a remote. See the “R” option in the Appendix.
- **GFCI:** Outlet protection; 20 A self-testing receptacle.
- **GFCI Output Breaker:** Trips to protect the GFCI from shorted AC loads or overload situations.
- **Output Breaker:** Trips to protect the internal circuitry from shorted AC loads or overload situations. Rated for 30 A.
- **BTS:** Allows for proper temperature charging across the operating range of the inverter.
- **CAN Port:** DB9 port used for CAN control of inverter/charger.
- **AUX Ports and Connectors:** Currently provides no function. May be filled with blank plugs.
- **Thermally Controlled Cooling Fan**
- **Low Battery Protection:** Automatically shuts down the inverter at 21.0 VDC with inrush delay.
- **High Surge Rating for Large Motor Loads**
- **Rugged Design for RV/Mobile Environments**
- **Battery Configuration:** Standard models are configured for use with AGM batteries (for charging). Options for battery type include wet, AGM, gel, and LFP (lithium iron phosphate or LiFePO₄). Additionally, there are four battery profile options for LFP. The battery type may be changed using the optional LCD remote or through the RV-C CAN tool.

Contact the factory for updated information or for other voltage, current ratings, and battery configurations that may be available.

INSTALLATION

Mount the Inverter

NOTE: The inverter mounting location should provide adequate ventilation and clearance to maintain room temperature during operation. At least 1/2" of clearance is required on all sides except the bottom. This includes 1/2" beyond the mounting flanges and DC terminal covers.

Installation Tools

The following tools may be required for inverter installation:

- Wire Termination Crimper
- Cable-Ties
- Drill
- 9/16" Socket or Open Ended Wrench
- Phillips Screwdriver
- Tape Measure
- Wire Cutters
- Wire Strippers
- 3/16" Slotted Screwdriver

Installation

1. Locate a suitable, secure, vertical or horizontal mounting surface as close to the batteries as possible without being in the same airtight compartment.
2. Mount the inverter using four 1/4-20 steel bolts, flat and lock washers, and nuts. The length of the bolts should be equal to the mounting material thickness plus 3/4".

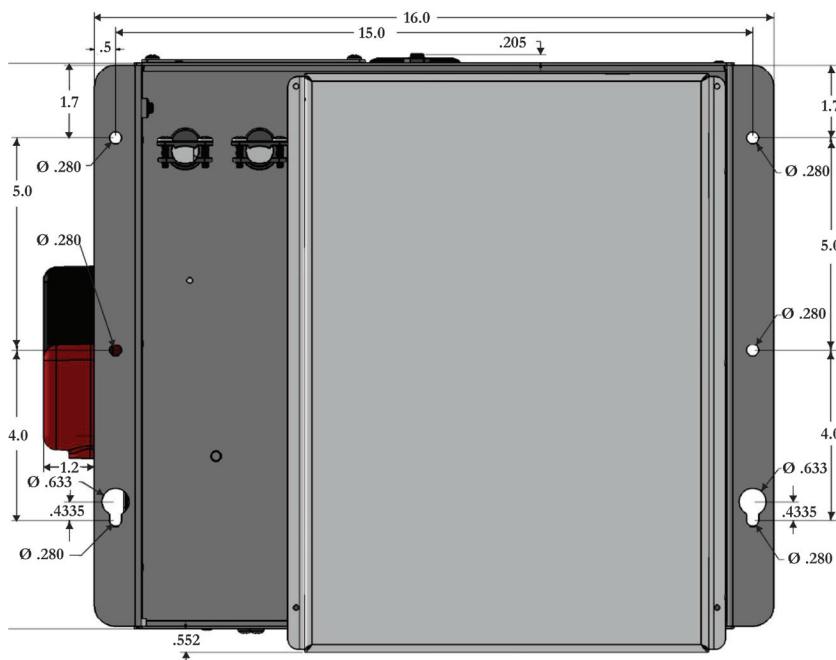

Figure 2 Large Models Mounting Pattern (Units in Inches)

Typical Wiring Diagram

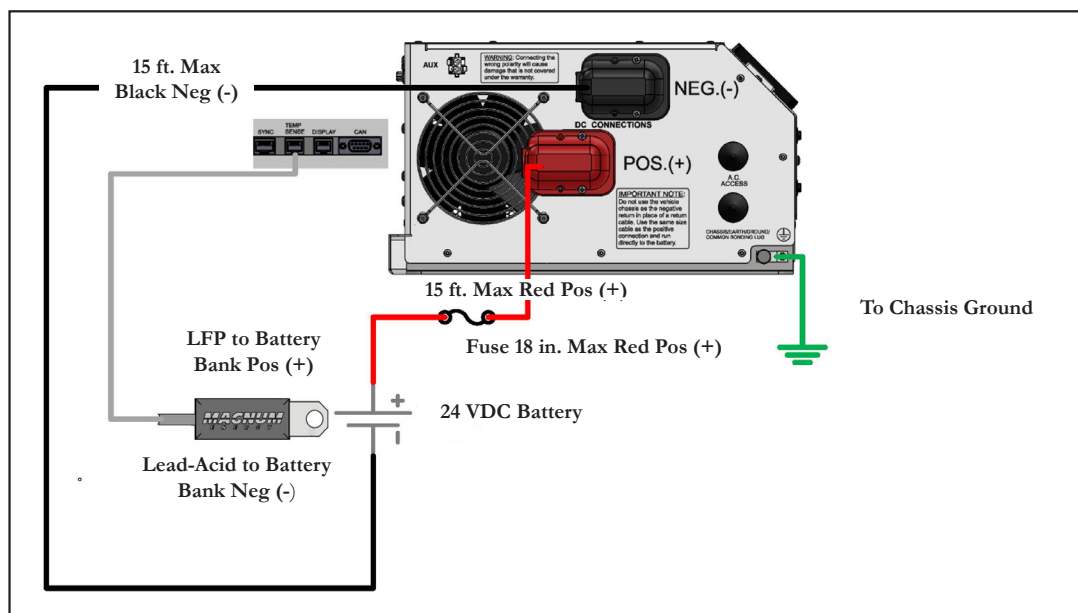

Figure 3 Typical Wiring Diagram

1. Remove the fuse from the fuse holder.
2. Connect the inverter's bonding lug to ground of the vehicle chassis.
3. Connect the ring terminated end of the black cable set and the temperature sensor cable directly to either the negative (-) lead-acid battery post or to the positive (+) LFP battery post.
4. Connect the fuse holder to the positive (+) side of the battery bank.
5. Connect the ring terminated end of the red cable from the inverter to the fuse holder.
6. Inverter DC connectors should be torqued to 160–165 inch-pounds.
7. Install the fuse in the fuse holder. A typical one-time spark will occur when this final connection is made. Install the fuse cover.

DC Wire Gauge & Fusing

An “Inverter Cable Kit” (positive cable, negative cable, and proper fuse) is needed to connect the inverter to a battery bank. An 8 AWG single-strand cable is also recommended to connect the inverter’s bonding lug to ground.

The inverter cable length and the size of the inverter will determine the cable gauge and the fuse size to use. The maximum recommended length for the inverter cable is 15 feet. The cable must be fused within 18 inches from the positive (+) terminal of the battery.

Cross reference the inverter model and the estimated cable length in the table below to determine the proper cable gauge and fuse size. An inverter cable kit designed to SAE guidelines can be purchased directly from our factory – call for options.

Min. Cable and Max. Fusing Guide for 3% Voltage Drop — 100% Duty Rating

Inverter Model	Full Load Amps DC	Inverter to Battery Estimated Cable Length in Feet			
		1 to 5 feet	6 to 10 feet	11 to 15 feet	16 to 20 feet
24NP36	167	2/0 AWG, 400 A Fuse	3/0 AWG, 500 A Fuse	3/0 AWG, 500 A Fuse	3/0 AWG, 500 A Fuse

Installation

Min. Cable and Max. Fusing Guide for 3% Voltage Drop — 50% Duty Rating

Inverter Model	Full Load Amps DC	Inverter to Battery Estimated Cable Length in Feet			
		1 to 5 feet	6 to 10 feet	11 to 15 feet	16 to 20 feet
24NP36	167	1 AWG, 300 A Fuse	1 AWG, 300 A Fuse	1/0 AWG, 350 A Fuse	2/0 AWG, 400 A Fuse

Table 2 DC Fusing Guide

NOTE: 100% duty rating assumes the inverter is operating at its full rated output power continuously for at least thirty minutes. The 50% duty rating assumes that the inverter is operating at its full rated output power for up to 15 minutes and then operating with a load less than 25% of its full rating for at least 15 minutes before returning to full power and repeating. Alternatively, it can also operate at 50% of its rated output power continuously. Table values assume operation in an ambient temperature of 25°C (77°F). For higher ambient temperatures, additional derating may be required (i.e. may need to use a larger cable size).

NOTE: The DC input terminals will only accept one cable with the provided cover installed. Cover not required for use.

Make an “Inverter Cable Kit”

1. Use stranded copper cables in all cases.
2. Use SGX cross-linked polyurethane insulation type that complies with the high temperature insulation requirements (125°C) of SAE J-1127 and vehicle manufacturer requirements.

AC Input & Output Connections

- ▲ **WARNING:** Do not connect another source of AC power directly to the output of the inverter. This will result in damage not covered under warranty.
- ▲ **WARNING:** Do not reverse the input and output AC connections. This will result in damage not covered under warranty.

The inverter's 120 VAC output power is provided at the GFCI receptacle and the hardwire terminal blocks behind the access panel. Wire the AC input to the hardwire terminal blocks behind the access panel for charging and shore power.

1. Remove the black hole covers as needed for hardwire AC wiring. Use a Romex type clamp to protect the wires from the metal edge of the hole.
2. Apply 14.0 in-lbs torque to the terminal block screws on DIN rail style and 14.6 in-lbs on the white modular style.

NOTE: Systems rated at 2400 watts and above, the AC input should be protected by a 30 A branch rated input breaker external to the inverter/charger.

NOTE: Connecting the AC inverter input to a GFCI protected outlet may cause some interference with the inverter's GFCI.

NOTE: The AC output should be protected by a branch rated breaker external to the inverter if required to comply with the NEC, NFPA 70, or the Canadian Electrical Code, C22.1.

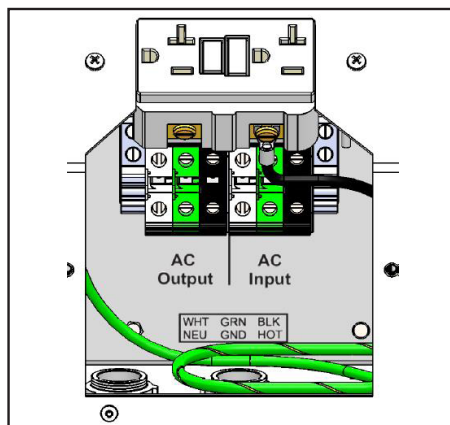

Figure 4 AC Wiring Terminals

BTS Connection

Charger operation with a battery temperature sensor, or BTS, cable is required. The BTS measures the battery temperature and automatically adjusts the charger output for the fastest and safest charge.

Lead-Acid

When batteries are cold, their chemical reaction is slowed, and the battery will not charge as easily in this condition. A charge voltage optimized for room temperature will not charge the battery at low temperatures. The temperature sensor cable allows the charger to increase the charge voltage for optimum charging at low temperatures.

When batteries are hot, their chemical reaction is accelerated, and the batteries absorb energy too readily. A charge voltage optimized for room temperature will tend to overcharge the batteries and cause gassing. The BTS will cause the charger to decrease the charge voltage to a safe level.

The charger will switch to a “warm battery” mode in which the charger will only provide a float voltage when the batteries are between 50°C/122°F and 60°C/140°F. If the battery temperature continues to rise over 60°C/140°F the charger will shut off. The charger will resume charging in the “warm battery” mode when the battery cools to 55°C/131°F. The charger will resume normal charging when the battery cools to 45°C/113°F.

LFP

Lithium Iron Phosphate (LFP) batteries should not be charged at temperatures less than 0°C/32°F as this may permanently reduce the battery capacity. The Dimensions inverter/charger can support different profiles or modes for cold charging. The charger can be set to shut down once it reaches the cold shutdown threshold or it can be set to ignore (not use) the cold shutdown threshold. If set to cold shutdown: After the battery temp sensor warms to the charge ok temp there is a delay before charging starts. This delay allows the cells located inside the battery time to warm as there is a thermal lag from the internal cells to the battery post where the battery temp sensor is located.

NOTE: If a user has a battery with a heater, the user should choose profiles with cold shutdown disabled or “not-used.” Ignoring the shutdown will allow the charger to supply voltage to the battery heater (and any other connected DC load). The current will still be limited to 0.1C so most DC loads should still not be used.

BTS Connection Continued

Install the BTS

1. Connect the lug end of the battery temperature sensor to the battery.

NOTE: Lead-acid battery type will connect the BTS to the negative post of the battery. LFP battery types will connect the BTS to the positive post of the battery.

2. Connect the connector to the appropriate port located at the rear of the inverter labeled “Temp Sense.” The BTS is part# ME- BTS-XX (XX=length in feet - 6, 8, 15, 25, 40). The 40 ft version comes standard with the inverter/charger (unless a non-charger version is ordered).

NOTE: If the BTS is not connected, the battery charger will not function.

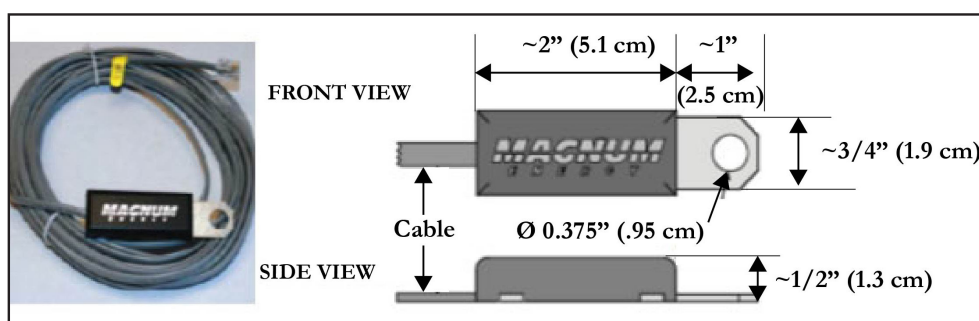

Figure 5 Battery Temperature Sensor

Remote Operation

Install 7-Segment Display Panel

The 7-segment display panel can be removed from the inverter and installed in a different location in the vehicle for remote control and monitoring.

1. Unscrew the two screws that hold the panel in using a 3/32" Allen wrench.
2. Disconnect the RJ45 connector from the back of the remote panel.
3. Install the RJ45 connector to the backside of the replacement RJ45 cover plate.

⚠ WARNING: Mount the RJ45 cover plate on the inverter with the two screws provided in the remote extension kit (8-32x3/8"). DO NOT USE the screws that held the display to mount the RJ45 cover plate. Using any other screw type or length than that provided in the kit may damage the inverter and/or harm the installer. Tighten the screws to 16–17 inch-pounds.

4. Connect the extension cable to the RJ45 jack.
5. Route the cable through the vehicle to the desired location.

NOTE: Avoid routing the RJ45 connector around high current power cables.

6. Install the remote display panel at the desired new interior location using installer supplied #8 screws and connect the extension cable to it.

To mount remotely, the 7-Seg Display panel will require the mounting hole and screw positions shown below:

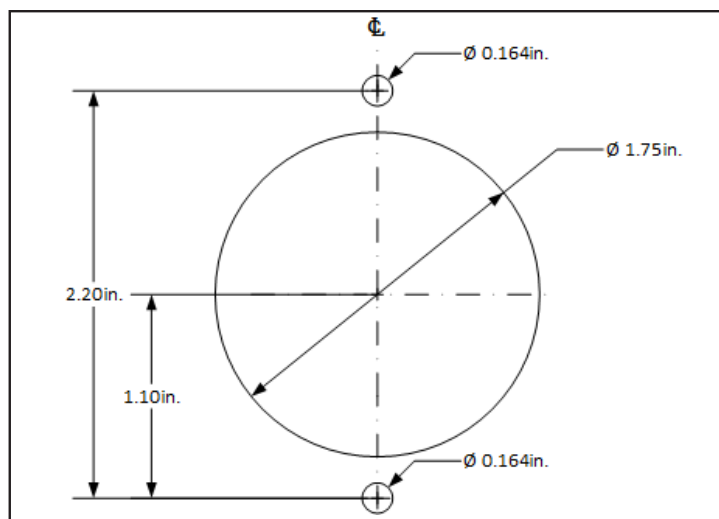

Figure 6 Seven-Segment Display Hole Pattern

Installation

Remote Operation Continued

Remote Inverter “On/Off” Switch

An optional customer-supplied remote switch can also be used to control the inverter.

Install Remote Inverter “On/Off” Switch

1. Using an insulated female faston and 18 AWG wire, wire between the “Remote On/Off” connection on the right side of the inverter and the remote switch.
2. Wire from the remaining connection on the remote switch to the battery.
3. Install a 5 A in-line fuse installed in series within 18 inches from the positive (+) terminal of the battery.

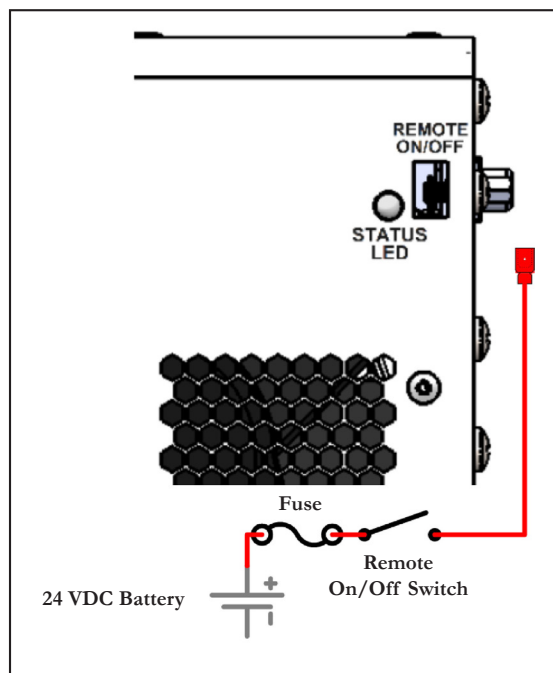

Figure 7 Remote On/Off Wiring

NP Control Board Pinout

An additional switch may be installed as an optional way to enable the inverter. Enable remote operation by installing a switch between between the pin 4 and 6. The installed switch must be rated for 80 V minimum.

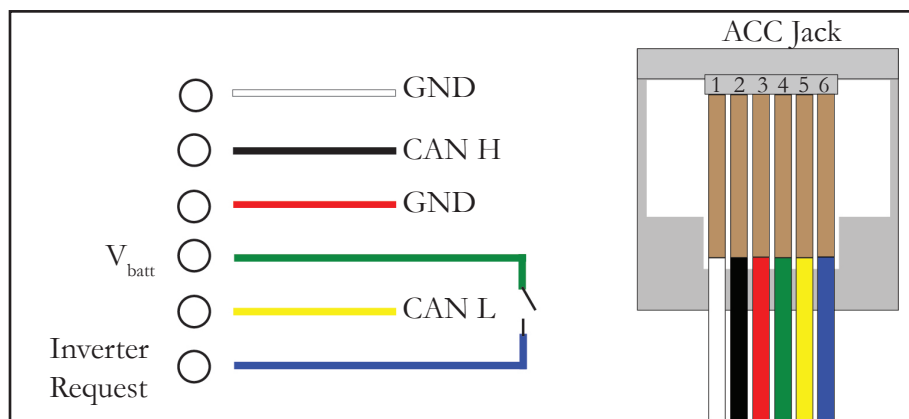

Figure 8 Pinout

Installation

Board Pinout

ACC / Remote (RJ12)	PIN 1 & 3	Digital Ground
	PIN 2	CAN-H
	PIN 4	Remote + (Output, DC Power Fused at 2 Amps)
	PIN 5	CAN-L
	PIN 6	Inverter Request (Input)
Battery Temperature Sensor (RJ12)	PIN 1	N/C
	PIN 2 & 5	Sensor Signal Input
	PIN 3	Sensor Ground
	PIN 4 & 6	N/C
CAN Bus (DB9)	PIN 1, 4, 5, 6, 8, & 9	N/C
	PIN 2	CAN-L
	PIN 3	CAN REF, GND (N/C)
	PIN 7	CAN-H
SYNC/STACK (RJ45) - Not Yet Supported	PIN 1 & 2	Digital Communication
	PIN 3 & 4	N/C (Not Connected)
	PIN 5 & 6	Digital Communication
	PIN 7	N/C
	PIN 8	Inverter Request (Output)

Table 3 Pinout

OPERATION

Inverter Power Mode

Control the inverter with the display panel “On/Off” key or a voltage between 8 and 32 volts applied to the “Remote On/Off” input tab.

The 7-segment display panel “On/STBY” LED will be green, and the status LED will blink amber while the inverter is on. The AC power produced by the inverter comes from the energy stored in the battery bank. A transformer, a Metal Oxide Silicon Field Effect Transistors (MOSFET), a filter capacitor, and microprocessor control are used to generate clean AC power with THD <5%.

The inverter will operate at DC input voltages ranging from 21 to 34 volts. If the DC input measures between 33 and 34 volts for greater than five minutes, the inverter will shut down. Above 34 volts, the system will stop operating due to input voltage being out of range. The inverter can tolerate up to 34 VDC input. When the input voltage drops to 21.0 volts, the inverter will stop operating due to a low battery condition. When the lead-acid battery bank voltage drops to 21 volts, the battery is considered to be fully discharged.

NOTE: Inverters have a large capacitance on the DC input terminals. If the capacitors are discharged when LFP batteries are connected, a large inrush current may occur. The inrush current may cause the BMS within the LFP battery to immediately disconnect. This issue will occur if the amount of connected battery amp-hrs is not sufficient to support the inverter size.

External Power Mode

The 7-segment display panel will show charger mode and output and the status LED will blink green indicating that there is a valid external AC power line applied to the inverter AC input. There may be a 30 second delay before charge or bypass is enabled while the AC input power is qualified.

Bypass Relay

The loads attached to the inverter output will operate directly from the external AC power line independently of the inverter on/off status. If the inverter is left on (standby mode), the built-in bypass relay will automatically cycle back and forth between “inverter power” and “external power” mode depending on the availability of the external AC power line.

Battery Charger

▲ WARNING: Customer must match battery type with charger battery type.

The battery charger will engage automatically and independently of the inverter on/off status.

NOTE: When in charge mode, the charger may not be able to charge at its full capacity if AC power is being used in bypass mode.

NOTE: The charger is capable of charging AGM, gel, wet lead-acid, or LFP batteries. The battery type may also be set via the 7-Seg Display, the optional LCD remote display (sold separately), or RV-C CAN. Contact factory for further details on RV-C CAN. The LCD part number may be found in the Appendix.

External Power Mode Continued

Battery Charger Continued

Battery Type		AGM	Gel	Wet	LFP
Bulk Charge Phase					
Bulk	Current Limit	SEE SPEC			
	Phase Terminates	<ol style="list-style-type: none"> When battery voltage reaches the accept voltage When the bulk charge timeout is reached 			
	Phase Timeout	6 Hours Bulk charge timers will extend when load management reduces charger current below 50% (25 A)			
Accept Charge Phase					
Accept	Accept charge voltage @ 77°F/25°C	28.6 VDC	27.4 VDC	29.2 VDC	28.8 VDC
	Accept voltage temp compensated	5mv/cell/°C			
	Maximum accept charge at low temps	30.0 VDC @ 4 °C	29.0 VDC @ -6°C	30.0 VDC @ 10°C	N/A
	Phase Terminates	<ol style="list-style-type: none"> When charge current is reduced. When the accept timeout is reached. If the charger can't maintain the accept voltage 			
	Phase Timeout	6 hours (may be configured through CAN or LCD)			0.5 hours
Float Charge Phase					
Float	Float voltage @77°F/25°C	26.8 VDC	26.8 VDC	26.4 VDC	27.2 VDC
	Float voltage temp comp	5mv/cell/°C			
Condition (Equalization) Phase					
Condition	Condition voltage @77°F/25°C	N/A	N/A	15.5 VDC	N/A
	Condition voltage temp compensation	N/A	N/A	30.24 mV/cell/°C	N/A
	Condition duration	N/A	N/A	4 hours	N/A
	Condition frequency	N/A	N/A	Manual Control	N/A

Operation

Table 4 Battery Charger Recipes with BTS

External Power Mode Continued

Battery Charger Continued

Battery Type		AGM	Gel	Wet	LFP
Battery Temperature					
Battery Temp	Charger Warm Battery: output switches to compensated float from bulk/accept/off (hot)	>50°C/ 122°F <60°C/140°F			N/A
	Charger High Battery Temp: output to off	>60°C/140°F			See Profile
	Charger resumes in previous mode: bulk/accept/float	<45°C/112°F			Profile value -5°C
	Charger Low Battery Temp Off: output to off	N/A			See Profile
	Enter 0.1C charge rate from Charger Low Temp Off	N/A			Chg Low Temp Off value +5°C
	Enter 0.1C charge rate from bulk/accept/float	N/A			See Profile
	Charger 0.1C charge rate recovery to bulk/accept/float mode	N/A			See profile value +5°C*

Table 4 Continued Battery Charger Recipes with BTS

*Profile value +15°C when charge cycle starts cold plus elapsed minimum time in mode.

Load Management

Incoming AC power is shared between the AC loads and the charger. The AC loads are given priority; this means that the charger will reduce its output when AC loads are applied. This feature also controls the total amperage draw of the system so that the utility service circuit breaker is not tripped. The load management feature will return the charger to full output when the AC loads are removed or reduced.

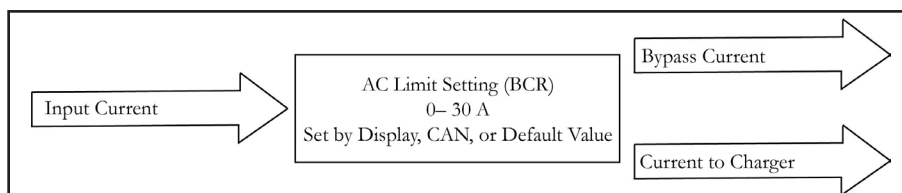

Figure 9 Load Management

The total amperage draw of the system is controlled by the AC limit setting also known as the BCR. These terms may be used interchangeably. The default AC limit is set by the factory to 15 A. The BCR may be changed at the factory or through the NVM Setup Utility, 7 Seg Display, or the optional LCD remote.

NOTE: Dynamic external loads (such as motors or pumps that continuously vary the power required) may cause variations in the charge rate. The charger may reset if the dynamic load causes the input AC waveform to become temporarily disqualified.

External Power Mode Continued

Cold Charging (LFP Only)

Under normal charger operation, if the battery temperature drops below 5°C/41°F while charging, the charger will switch to 0.1C charging. If the temperature increases to 10°C/50°F, the charger will resume normal charging. If the charger drops to 0°C/32°F, the charger will shut down, and it will restart 0.1C charging at 5°C/41°F. When the charge cycle first starts up and immediately enters Cold Charger Off or 0.1C charging, the charger will lengthen the charge cycle times to help ensure that the battery is warm enough to accept a charge current.

The 0.1C temperature setpoint and Cold Charger Off setpoint are adjustable with the optional LCD. The recovery thresholds are always 5°C/41°F ($\Delta 5^{\circ}\text{C}/9^{\circ}\text{F}$) higher than the setpoint when the charge cycle starts above the 0.1C temperature threshold. When the charger starts the charge cycle in 0.1C mode or Cold Charger Off mode, then the recovery threshold between 0.1C charging and normal charging is 15°C/59°F ($\Delta 15^{\circ}\text{C}/27^{\circ}\text{F}$).

Operation Using 7-Seg Display

Once the inverter has been fully installed, wired, and DC power has been applied, the 7-Segment (“7-Seg”) display panel will power on. This display panel shows the status and configuration information of the inverter and charger. The inverter can be turned on and off by pressing the “On/Off” key. Configuration changes can be made using the “Menu” and “Display/Select” keys.



Figure 10 Seven-Segment Display Panel

Once DC power is applied, the first message that is visible on the 7-Seg Display is:

chGr InU OFF chEc Ac

This message is “charger inverter Off check AC,” meaning that both the charger and inverter are off and that the unit is not plugged into shore power. Otherwise, there may be a problem with AC power coming to the unit.

Operation Using 7-Seg Display Continued

Inverter Power Mode (Using 7-Seg Display Panel)

Turning the Inverter On or Off (No AC Applied)

Press the “On/Off” key to turn on the inverter. The “On/STBY” LED will turn green. Press the “On/Off” key again to turn the inverter off. While the inverter is on, the following message will display:

INV 550 bAtE 25.2v

This message shows that the inverter is on, the load is consuming 550 watts of power, and the battery voltage is at 25.2 volts.

Standby

The inverter standby feature allows the inverter to automatically power on anytime that the unit senses a loss of shore power. The unit will go back to standby when shore power is returned (after 30 seconds of line qualify time). Enable the standby feature by turning the inverter on by pressing the “On/Off” key. If this the unit is powered on while shore power is applied, the “On/STBY” LED will turn amber and the display will show:

INV StbY Ovrd chGr

This message is stating that the inverter is in standby and that to exit this mode you need to press the “On/Off” key. Exit inverter standby mode by pressing the “On/Off” key. If you turn off the inverter while shore power is applied, the display will show:

INV StbY Push OFF

This message is stating that the inverter is off and that, to put it back to standby, “On/Off” (STBY) key. must be pushed.

Other Messages

INV LOB bAtE 19.6v

This message indicates that there is a low battery condition due to start surge or undersized battery cable gauge. If this condition remains for >5 seconds, the inverter will shut down.

INV OL bAtE 23.6v

This message indicates that there is an overload condition due to excessive loads or short circuit. If this condition remains for >5 seconds, the inverter will shut down. The inverter will immediately shutdown in an overload when the output is short circuited or if the battery voltage is low upon start-up.

Operation Using 7-Seg Display Continued

Inverter Power Mode (Using 7-Seg Display Panel) Continued

Battery Test

The battery voltage can be tested at any time by pressing the “Batt Test” key. The mode will stay active for 1 minute or until the “Batt Test” or “Menu” key is pressed.

Battery Minimum (Low Battery Voltage Point)

If the inverter temporarily shuts down while in use due to a low DC input condition, it is possible to check how low the DC input voltage was measured. See the low DC input voltage by pressing the “Batt Test” key followed by the “Display Select” key. The display will show “Lo bAtt” followed by the recorded minimum low input condition voltage. The mode will stay active for 1 minute or until the “Batt Test” or “Menu” key is pressed. The following message shows the low point at 20.2 volts:



```
Lo bAtt 20.2v
```

If there is no value stored, the message will not list any voltage.

Clear the stored value manually by pressing the “Display/Select” key while the message is scrolling. The following message flash twice:



```
CLR bAtt
```

The new recorded value will replace the old value.

Operation Using 7-Seg Display Continued

External Power Mode (Using 7-Seg Display Panel)

AC Input Limit (BCR max limit)

The maximum AC current that the charger will be allowed to draw is adjustable. The default setting is 15 A. Press “Menu” to display the current setting. The message will then scroll:

AC In LIm 15A

To change the value press “Display/Select” and the value will decrease in 5 A increments. The charger stores the last value shown on the display. More information on setting the BCR max limit can be found in the Appendix.

Charger Modes

The battery charger will engage automatically and independently of the inverter on/off status. The 3-step charging process modes are bulk, accept, and float.

NOTE: The 7-Seg display uses the term “bulk” for constant current and “acceptance” for constant voltage. The terms may be used interchangeably throughout this document.

The display panel will state which mode the charger is in when shore power is applied. The mode, charge voltage, and current will be displayed.

Display	Charge Mode
ChGr bULt 244u 0A	Bulk Mode
ChGr AcPt 292u 0A	Accept Mode
ChGr FLOt 262u 0A	Float Mode

Table 5 Charger Mode

Battery Temperature Sensor

If the BTS is not inserted into the “Temp Sense” connector on the rear of the inverter, the battery charger will not function, the red “Fault” LED will come on, and the display will show:

ChGr OFF bAtE Pr0b

“Pr0b” refers to the Battery Temperature Sensor.

Disconnect AC Power.

Connect BTS to inverter/charger.

Reconnect AC Power.

Operation Using Remote “On/Off” Switch

The inverter is ready to turn on once the inverter and remote “On/Off” switch has been fully installed, wired, and DC power has been applied. The status LED on the right side of the inverter shows the status information of the inverter and charger.

Inverter Power Mode (Using Remote “On/Off” Switch)

Turning the Inverter “On” or “Off” (no AC applied)

The inverter can now be turned on by turning on the remote switch. When the inverter is on, the status LED will blink amber.

Turning the Inverter “On/Off” remotely via CAN commands.

RV-C CAN commands may be used to remotely enable and disable the inverter. For CAN to work, the remote switch must be in the “on” position. The remote switch is required to enable the inverter’s housekeeping power supply, which allows it to receive CAN commands. Contact the factory for additional information.

External Power Mode (Using Remote “On/Off” Switch)

Bypass Relay

The loads attached to the inverter output will operate directly from the external AC power line independently of the inverter on/off status. If the inverter is left on (standby mode), the built-in bypass relay will automatically cycle back and forth between “Inverter Power” and “External Power” mode depending on the availability of the external AC power line.

Battery Charger

The battery charger will engage automatically and independently of the inverter on/off status. The 3-step charging process modes are: bulk, accept, and float. The status LED will state which mode the charger is in when shore power is applied.

GFCI Operation

A GFCI measures the amount of AC current into the GFCI line side “hot” and “neutral” terminals. Both terminals should measure the same amount of current under normal conditions. Any difference in current is considered the leakage current. If the leakage current is greater than 5mA, the GFCI will trip. A tripped GFCI suggests that there has been a breakdown in the electrical insulation of a connected device. This can result in a safety hazard for the user. The breakdown could have been caused by broken wire insulation with the live wire contacting the ground conductor, water in contact with a live conductor, or any other inadvertent electrical path to ground.

The GFCI has a status LED on it. When installed with a Leviton GFNT2 GFCI, the LED will operate as follows:

GFCI Status LED		
LED Color & State	Condition	Action Required
Green — Constant On	GFCI is powered from the line side and operating correctly	None
Red — Constant On	Fault found during normal operation	Press “Test” to trip the GFCI. If it fails to reset after pressing “Reset,” the GFCI will need to be replaced.
Red — Blinking	Fault found during self-test	Press “Test” to trip the GFCI. If it fails to reset after pressing “Reset,” the GFCI will need to be replaced.

Table 6 GFCI Operation

Operation

The GFCI installed in this inverter is compliant with the latest requirements for GFCI’s per UL 943. This includes automatic self-testing and line-load reversal.

NOTE: For GFCI protected hardwire output (“A” option), replacement GFCIs must be wired directly to the GFCI “Load” terminals. Verify the connections are installed to the unused “Load” terminals. Turn off AC and DC power sources before replacing the GFCI. Refer to Table 11 for replacement GFCI models.

Self-Testing

The GFCI will periodically test the ground fault detection circuit in the background. If the test determines there is a problem with the detection circuit, the GFCI will trip and/or notify the user visually with the status LED. The GFCI will perform a self-test when AC power is first applied to it.

Line-Load Reversal

If the line and load terminals are wired backwards, the GFCI will not reset and power will not be available until the wiring has been corrected.

NOTE: Depending on the GFCI model that is used, the line and load terminals on the rear may not be in the same position. The user must verify the GFCI markings to ensure proper connection.

Operation with Optional LCD Remote

LCD Remote

A LCD remote may be purchased separately for “R” suffix models to connect to the inverter through the RJ45 port on the front of the inverter. The remote display will provide the current input voltage and output wattage of the inverter while in inverter mode. When in charge mode, the display will provide the output voltage and current. When the inverter is operating under a fault condition, the display will provide the fault condition.

Once the inverter/charger has been fully installed and wired, and power has been applied, the optional LCD remote panel will be active. This display panel shows the status and configuration information of the inverter/charger by pressing the “Info” key. The inverter can be turned on and off by pressing the “On/Off” key and make configuration changes by holding down the “Display” key to enter a settings menu.

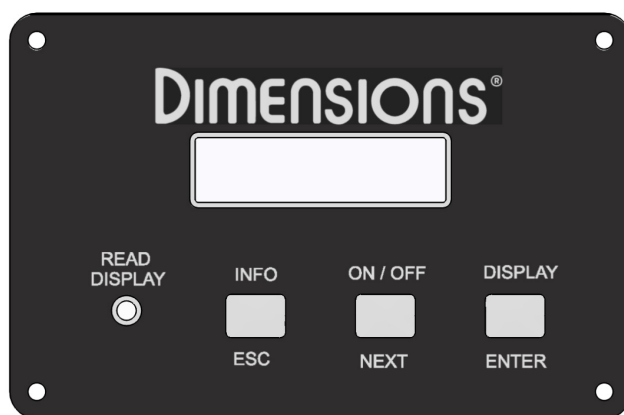

Figure 11 LCD Remote Panel

Once DC power is applied, the first message on the remote display will be “Inverter Off/ System Off.” This message means that both the charger and inverter are off and that the unit is not plugged into shore power. Otherwise, there likely is a problem with the AC power coming to the unit.

Refer to the owner’s manual for further details on the operation of the LCD remote. The standard Dimensions display model number is 141537. The remote display may be purchased separately from the factory.

Either the optional remote or any remote “On/Off” switch may be used to turn on the inverter. To turn off the inverter, all remote “On/Off” switches and the optional LCD remote must be switched off. If any of these are still on, the unit will continue to operate.

LCD Configurations

	Display	Device Enable
Options	Always On	Press Once
	1 Minute	Press Twice
	10 Minutes	
Default	Always On	Press Once

Table 7 Setting Options

CONFIGURATIONS

Setting Configuration with Non-Volatile Memory (NVM) Setup Utility

The inverter/charger settings may be adjusted with a NVM Setup Utility kit which is sold separately. See the Appendix for the part number of the kit. The kit consists of a Kvaser® CAN interface which connects to a USB port on a laptop, a DB9 to RJ45 adapter, a terminating resistor, and a Windows PC program that can be installed on a x32 or x64 machine. The laptop is not included with the purchase of the kit.

After the software has been properly installed, the Kvaser device may be plugged into the computer. The first time the Kvaser is connected, the computer may need to download the appropriate Kvaser drivers from the Kvaser website. Once the Kvaser device is ready to be used, the terminating resistor and DB9 to RJ45 adapter may be connected to the inverter CAN port.

Once the inverter is turned on, the NVM Setup Utility may be opened on the laptop. The tool will automatically look for a CAN device on the network. Once a unit is detected, it will automatically connect and display the current settings.

NOTE: Only one CAN enabled inverter can be connected to the NVM Setup Utility at a time.

To make a settings change, click on a parameter and the available options will appear in a drop-down menu. Once a setting is changed, the change is immediately set into the inverter's memory. After making all the settings changes, it is necessary to turn the inverter off for 30 seconds and then turn it back on for the setting changes to take effect. The settings may be saved to a configuration file. The configuration file may be used to program any additional units that are to be programmed with the same settings.

Configurations

	Options			Increment	Default
Low Batt	21.0 V	to	24.0 V	.1 V	21.0 V (23.0 V for LFP)
BCR	5 A	to	30 A	5 A	15 A
AC Line Qualify	5 secs	to	30 secs	5 secs	30 secs
CAN Instance	1	to	13	1	1
Baud Rate	250k	or	500k	N/A	250k

Table 8 Setting Options

Settings	Battery Type			
	Wet	AGM	Gel	LFP
Battery Profile	1	1	1	See Table 10
Default CV	29.2 VDC	29.0 VDC	28.2 VDC	28.8 VDC
Min CV	24.0 VDC	24.0 VDC	24.0 VDC	27.8 VDC
Max CV	30.8 VDC	30.6 VDC	29.8 VDC	29.6 VDC
Default CV Timer	6.0 hrs	6.0 hrs	6.0 hrs	0.5 hrs
Min CV Timer	0.5 hrs	0.5 hrs	0.5 hrs	0.5 hrs
Max CV Timer	25.0 hrs	25.0 hrs	25.0 hrs	25.0 hrs
Default Float V	27.2 VDC	27.0 VDC	27.2 VDC	27.2 VDC
Min Float V	24.0 VDC	24.0 VDC	24.0 VDC	26.6 VDC
Max Float V	28.4 VDC	28.6 VDC	28.8 VDC	27.6 VDC

Table 9 Battery Charger Customization Options

Battery Type	Profile	High Temp Shutdown*	Cold Temp Shutdown*	Cold Reduced Charge*
LFP	1	45°C/113°F	0°C/32°F	5°C/41°F
LFP (HEATED)	2	45°C/113°F	None	5°C/41°F
LFP	3	60°C/140°F	0°C/32°F	5°C/41°F
LFP (HEATED)	4	60°C/140°F	None	5°C/41°F

Table 10 LFP Setting Options

*The LCD converts temperature settings into a Celsius integer before transmitting to the inverter. Setting changes of only 1°F on the LCD may not always change the setpoint within the inverter. Changes of 2°F will change the setpoint within the inverter.

0.1C charging is the feature in which the charger will reduce the charge current to ten percent of the amp hour rating. See the specification table for the default amp hour setting. The amp hour setting may be adjusted with CAN or the optional LCD remote.

Configurations Continued

Battery Options

The charger can be set to charge four different types of batteries: wet lead-acid, AGM, gel, or LFP. The charger is set to AGM by default by the factory. The battery type may be changed at the factory or through the NVM Setup Utility. To determine what type of battery the inverter is configured for, monitor the LED blink code at startup and reference the LED status chart.

Low Battery Shutdown

Low battery shutdown is a protective measure to prevent deep discharge of the battery and/or to make sure that the starting batteries have enough power to start the vehicle.

NOTE: The inverter may be de-rated when the input voltage approaches the low battery set-point. To conserve battery voltage, the internal inverter fan may turn off. This will cause the inverter to go into high temp shutdown if the load is large enough.

Branch Circuit Rating

The branch circuit rating (BCR) can be set to 0, 5, 10, 15, 20, 25, or 30 A. If set to 0 A, the charger will not enable, but bypass power will still be available. The default factory setting is 15 A. The BCR may be changed at the factory or through the NVM Setup Utility, 7 Seg Display, or option LCD remote.

Change the BCR on the 7-Seg Display

1. Press “Menu” once.
2. Press “Select” to cycle through available options.
3. Press “Menu” to exit.

AC Line Qualify Time

The AC line qualification time is the setting that adjusts the time that it takes for the charger and bypass to start once qualified AC power has been applied to the charger input. This time can be set to any value between 5 and 30 seconds, in 5 second increments. The default setting is 30 seconds. This setting may be changed at the factory or through the NVM Setup Utility.

CAN Instance and Baud Rate

The CAN instance can be changed from 1–13. This is useful if there are multiple inverters being used on the same CAN network. Multiple inverters should not share the same CAN instance. The baud rate may be changed between 250k and 500k. The default settings for the inverter are instance 1 and baud rate 250k. These values may be changed at the factory or through the NVM Setup Utility.

Custom Battery Changes

The CV timeout, CV VDC, float VDC, max charge ADC, and battery amp hour may be customized. For LFP batteries, the battery high temperature shutdown, low temperature shutdown, and cold reduced shutdown points may also be customized. These values may be changed through the NVM Setup Utility or optional LCD remote.

Ignition Switch Control with the 7-Seg Display Panel

The 7-Seg Display Panel can be wired to the vehicle ignition circuitry to control operation of the inverter. When the ignition is turned on, the inverter has a built-in delay which will turn it on after 10 seconds. For the inverter to work in this way, the 7-Seg Display Panel must be programmed for this type of operation. This is done by having either AC or DC power applied to the inverter and then following these instructions:

Ignition Programming



Figure 12 Seven-Segment Display Panel

1. Press and hold “Menu” & “Display/Select” for 5 seconds. The green “Fault” LED comes on.
2. Press “Menu” once. Display scrolls:

ctL tAb OFF

3. Press “Display/Select.” Display stops at:

OFF

4. Press “Display/Select” and the display changes to:

10n

The “On/STBY” LED will also blink amber (if unit is connected to AC power).

5. Press the “Batt Test” key. Disconnect power to the system and complete wiring.

Complete Wiring

1. Using an insulated female faston and 18 AWG wire, connect to the faston tab on the backside of the 7-Seg Display Panel.
2. Wire the other end through a 5-amp inline fuse to the ignition circuitry of the vehicle.

NOTE: Repeat steps 1–5 to turn this feature off again.

Branch Circuit Rating (BCR) Max Limit with the 7-Seg Display Panel

The BCR max limit sets the max limit that is adjustable by the 7-Seg Display. For example, if the limit is set to 15 A, the user may only select 0, 5, 10, or 15 amps. If the limit is set to 30 A, the user may then select from 0–30 amps in 5 A increments.

The connected 7-Seg Display will overwrite any other BCR value programmed into the inverter/charger by any other device.

The 7-Seg Display Panel can be used to adjust the BCR maximum limit. To adjust the 15 A default setting, the 7-Seg Display Panel must be reconfigured. Follow these instructions to adjust the BCR maximum limit:

1. Press and hold “Menu” and “Display/Select” for 5–10 seconds to enter configuration mode. The green “Fault” LED will come on.
2. Press “Display/Select” once. The current BCR maximum limit setting will be displayed.
3. Press “Display/Select” to cycle through the available setting options (15, 20, or 30 amps) until the desired setting is displayed.
4. Press “Menu” to confirm the desired setting. The chosen value will be displayed:



5. Press “Menu” twice to exit configuration mode. The green “Fault” LED will no longer be on.

Battery Type and Profile with the 7-Seg Display Panel

The 7-Seg Display Panel can be used to adjust the battery type. To adjust the setting, the 7-Seg Display Panel must be reconfigured. Follow these instructions to adjust the battery type:

Battery Type

1. Press and hold “Menu” and “Display/Select” for 5–10 seconds to enter configuration mode. The green “Fault” LED will come on.
2. Press “Menu” twice. The current battery type setting will be displayed.
3. Press “Display/Select” to cycle through the available setting options (FLd, GEL, AGM, and LFP) until the desired setting is displayed.
4. Press “Menu” to confirm the desired setting. The chosen value will be displayed:
5. Press “Menu” twice to exit configuration mode. The green “Fault” LED will no longer be on.

Battery Profile

1. Press and hold “Menu” and “Display/Select” for 5–10 seconds to enter configuration mode. The green “Fault” LED will come on.
2. Press “Menu” three times. The current battery profile setting will be displayed.
3. Press “Display/Select” to cycle through the available setting options until the desired setting is displayed.
4. Press “Menu” to confirm the desired setting. The chosen value will be displayed:
5. Press “Menu” twice to exit configuration mode. The green “Fault” LED will no longer be on.

TROUBLESHOOTING

▲ WARNING: Do not remove chassis cover. No user-serviceable parts inside. Call or e-mail customer service for free consultation during business hours. Business hours are 8:00 am –5:00 pm C.S.T.

Phone: 1-800-553-6418 or 1-651-653-7000

Fax: 1-888-439-3565 or 1-651-653-7600

E-mail: inverterinfo@sensata.com

Website: <http://magnum-dimensions.com/>

7-Seg Display Panel Messages

Condition	Display	LEDs	Action Required
Inverter Off Low Battery	InU OFF LoB bAtE	Green “On/STBY” Red “Fault”	Check battery charge and DC wiring cable size.
Inverter Off Overload	InU OFF OL	Red “Fault”	Check for output short circuits. Remove one or more loads from the output of the inverter. Reset the inverter.
Inverter Off High Temperature	InU OFF h ICh tRAn tEAP InU OFF h ICh FEt tEAP	Green “On/STBY” Red “Fault”	Inverter will turn back on automatically when the temperature has cooled down.
Inverter Off High Battery	InU OFF h ICh bAtE	Green “On/STBY” Red “Fault”	Inverter restarts when battery drops below 32.0 volts. Check the vehicle alternator/regulator.
Inverter Off Fault	InU OFF FLt	Red “Fault”	Check for output short circuits. Check the battery size and voltage. Reset the inverter.
Inverter Off Reverse Polarity	InU OFF rEU Polr	Red “Fault”	Inverter must be sent back to the factory for evaluation.
Charger Off High Temperature	ChGr OFF h ICh FEt tEAP ChGr OFF h ICh tRAn tEAP	Amber “On/STBY” Red “Fault”	Charger will turn back on automatically when the temperature has cooled down.
Charger Off High Battery Temperature	ChGr OFF bAtE h ICh tEAP	Amber “On/STBY” Red “Fault”	Check the battery compartment for proper ventilation.
Charger Off Battery Problem	ChGr OFF bAtE PrOb	Amber “On/STBY” Red “Fault”	Check BTS connections
			Check the battery voltage and cable connections.
			Reset, remove AC power for at least 2 minutes, and turn the inverter off.

Table 11 Seven-Segment Display Panel Messages

7-Seg Display Panel Messages Continued

Condition	Display	LEDs	Action Required
Charger Off Battery Low Temp (LFP Only)	CHGR OFF bAtt LOH TEMP	Amber "On/STBY" Red "Fault"	Raise battery temperature.
Charger Off Overload	CHGR OFF OL	Red "Fault"	Check DC wiring for a short or DC load issue.
Charger Off Low Battery	CHGR OFF LOH bAtt	Red "Fault"	Use alternative means to raise battery voltage.
Charger Off Battery Short	CHGR OFF bAtt SHrt	Red "Fault"	Check battery condition and connections.

Table 11 Continued Seven-Segment Display Panel Messages

7-Seg Display Panel Messages Continued

Inverter Off Low Battery

The inverter is off due to a low battery voltage condition (≤ 21.0 volts for 5 seconds).

Inverter Off Overload

The inverter is off due to an overload condition or output short circuit.

NOTE: If the inverter/charger has been disabled by CAN, the “Inverter Off Overload” message will appear. If using CAN with this system, check the inverter/charger LED blink code to verify cause.

Inverter Off High Temperature

The inverter is off due to a high temperature condition.

Inverter Off High Battery

The inverter is off due to a high charging voltage condition (> 34 volts) and the display reports the value. The inverter can tolerate between 33–34 VDC for 5 minutes; if this condition continues for over 5 minutes, the unit will shut down. Input voltages above 34 VDC will result in an immediate shutdown.

Charger Off High Temperature

The charger is off due to a high temperature condition.

Charger Off Battery Temperature

The charger is off due to a high battery temperature.

Charger Off Battery Problem

The charger may be off due to a shorted or open (missing) BTS.

Inverter Off Fault

The inverter is off due to a possible output short circuit or problem with inverter input.

Inverter Off Reverse Polarity

The inverter has detected that the battery is connected backwards. The inverter must be sent back to the factory for evaluation.

Charger Off Battery Low Temp

The charger is off due to low battery temperature. Damage may occur to the battery if charging is continued.

Charger Off Overload

The charger is off due to possible short or DC load issue.

7-Seg Display Panel Messages Continued

Charger Off Low Battery

The charger is off due to low voltage unable to support safe charge.

Charger Off Battery Short

The charger is off due to a battery short.

LED Status Chart

Status LED Normal States

LED Color	LED State	Operating Conditions
Green	1 blink	Bulk Charge
Green	2 blinks	Accept Charge
Green	3 blinks	Float Charge
Green	4 blinks	Load Management Active
Green	5 blinks	Equalization
Green	6 blinks	Cold Charging
Amber	1 blink	Inverting

Status LED Fault States

LED Color	LED State	Fault State
None	Off	No Power to Unit or Internal Fault
Red or Amber	Constant On	Internal Fault
Red	1 blink	Inverter Low Battery Shutdown*
Red	2 blinks	Inverter Overload Shutdown
Red	3 blinks	Transformer High Temperature*
Red	4 blinks	MOSFET High Temperature*
Red	5 blinks	Battery Sensor Open or Shorted
Red	6 blinks	Inverter or Charger Disabled by CAN
Red	7 blinks	0 Amp Limit Set**
Red	9 blinks	Charger High Battery Temperature*
Red	10 blinks	Charger Off, Overload
Red	11 blinks	Reverse Polarity (Not Implemented in All Models)***
Red	12 blinks	Low Battery Temperature Shutdown
Amber	2 blinks	Charger Warm Battery*
Amber	3 blinks	High Battery Voltage*
Amber	4 blinks	System Overload, Reset Required****
Amber	5 blinks	Charger Off, Battery Shorted***

Table 12 LED Status Chart

* Faults will self-recover when the condition returns to normal range

** If the AC limit is set to 0 A, there will be no current available and the charger will not operate, but bypass will still function. This fault will self-recover when the setting is changed to >0.

*** The inverter/charger must be sent back to the factory for evaluation.

**** Faults may be due to a short-circuited output or a low or weak DC voltage source.

LED Status Chart Continued

Battery Type LED States at Start-Up (5 Minutes)

LED Color	Battery Type
Amber - Green	Wet Lead-Acid
Amber - Green - Green	AGM
Amber - Green - Green - Green	Gel
Amber - Green (x4)	LFP
Amber - Green (x5)	Custom Battery Type*
Amber - Green (x6)	Error, Undefined Battery Type

Table 13 Battery Type LED States

* Custom battery settings available from factory, or adjustable using CAN or LCD remote. Not adjustable with the 7-Segment display. Some models may only allow the accept timeout to be adjusted.

Troubleshooting Guide

No AC output during inverter mode	No LED's On	Check the in-line fuse which is located within 18 inches from the battery's positive (+) post	
		Check if DC connections are tight and clean	
		Check if battery voltage is above 21.0 VDC	
		Check remote power switch	
	LED blinks amber once	Disconnect all loads and connect a test light to the GFCI outlet	Check if GFCI is tripped If test light is off, possible failed inverter
LED blinks green	Disconnect all loads and connect a test light to the GFCI outlet	Check if GFCI is tripped If test light is off, possible failed inverter	
LED blinks red	See "LED Status Chart"		
Low Battery	The use of a battery isolator is not recommended due to an excessive voltage drop across terminals.	Battery voltage must be above the low battery setpoint for the inverter to be on.	
		Check for proper DC wire gauge (see Wire Gauge & Fusing section)	
Overload	Unplug all loads and reset the inverter	If overload condition clears, check for short circuits or check load size versus inverter output wattage size.	
		If the overload persists, possible failed inverter	
High Temperature	Let the inverter cool down and check that the vents are not obstructed and that the fans are functioning.		
Check Battery	Reset the inverter (unplug/plug AC input cord from the utility power) and remove the fuse from the fuse holder. Turn "on" the inverter for 30 seconds. Turn "off" the inverter. Re-install the fuse.	Check for shorted battery cell or corroded/loose DC wires	
		Check voltage and current against charger recipe table	
Undercharged Battery	Check battery type selection. For LFP battery type, check battery amp-hr setting.		

Table 14 Troubleshooting Guide

Accessories & Replacement Parts

Part Number	Item Description
215018	Box Lug, 300MCM– 6AWG Type B/C, 4/0 – 6 AWG Type G-K CU9AL UL/CSA
250031	AC cover plate #8-32 x 3/8" Phillips screw
250369-1	DC connector internal tooth 3/8" washer
250430	DC connector brass 3/8" flat washer
250436	DC connector hex bolt 3/8"-16 x 5/8"
250437	DC connector cover screws #6-19 x 5/8"
251048	Compression lugs for battery cables (2 of 215018 included)
310100	DC connector only black
310100-1	DC connector, cover, all hardware black
310101	DC connector only red
310101-3	DC connector, cover, all hardware red
310102	DC connector cover black
310102 -10	DC connector cover black (includes hardware)
310103	DC connector cover red
310103 -10	DC connector cover red (includes hardware)
430001	Faceless GFCI outlet
430005	20 A GFCI outlet
430010	Fuse 200 A, ANN-200
430012	Fuse 300 A, ANN-300
430054	Fuse 350 A, ANN-350
430019	Fuse 400 A, ANN-400
430060	Fuse 500 A, ANN-500
431021	Fuse holder with cover
540012	Slotted hex power bit, 4F-5R 3" for AC terminal blocks
625000	7-Segment Display Remote extension kit
ME-BTS-XX	Battery temperature sensor (-xx = 6, 8, 15, 25, or 40 ft in length)
245052	NVM Setup Utility kit (includes cable, terminating resistor, DB9 gender changer, CAN interface, and software)
612015-CAN	NVM Setup Utility (provided on a flash drive)
GFCI Replacements	
Leviton	GFNT2
Hubbell	GFR5362SGW
Cooper	TRSGF20
Pass & Seymour (Legrand)	2097

Table 15 Accessories & Replacements

NOTE: Only use the exact replacement part unless instructed to do otherwise by the factory. Other types may fail to operate properly when connected to this unit.

System Default Settings

Inverters as shipped from the factory default to the settings in Table 12.

Setting	Default Value
Low Battery	21.0 VDC
Branch Circuit Rating	15 A
Battery Type	AGM

Table 16 System Default Settings

The battery type and low battery setting may be changed by CAN, 7-Seg Display, or the optional LCD remote. Only the branch circuit rating can be changed with the 7-Seg display. The RV-C CAN ID will default to 1 and the baud rate to 250k.

Inverter Charger Model Options

Option	Description
G2N	Dual GFCI, inverter only (no charger or bypass relays), adds a second 20 A branch breaker
H	No GFCI or branch breaker, hardwire only
L	Local “On/Off” switch, non-upgradeable
N	Inverter-only (no charger, no bypass relays)
R	RJ45 remote jack (instead of 7-Seg display, includes plate and jack — no cable or display) Order if using a LCD remote or 7-Seg display used remotely.

Table 17 Inverter Charger Model Options

CAN

The inverter is compatible with RV-C CAN, developed by the RVIA (Recreational Vehicle Industry Association). CAN allows for the inverter to communicate with other units on the network.

For CAN to work properly, the inverter and all other units on the CAN network must be using the same CAN protocol. If the protocols are different, the units will not recognize each other. The typical RV-C CAN network is operated at 250 kbit/s, but the inverter may be configured for 500 kbits/s. Up to 13 inverter/chargers can be placed on the CAN network. Each inverter/charger requires a unique instance to differentiate it from similar units. If the inverter is connected to a network operating at a different Baud rate or a network that uses a proprietary communications protocol, the inverter may not respond.

The inverter/charger supports most standard RV-C instructions in addition to several custom commands for configuration changes. Contact the factory for more information. Reference document #131557 for further descriptions of the included RV-C instructions.

Supported Standard RV-C instructions include (not limited to):

Command	DGN Number
Charger Command	1FFC5h
Charger Configuration Command	1FFC4h
Charger Configuration Command 2	1FF95h
Charger Configuration Command 3	1FECBh
Charger Configuration Command 4	1FEBEh
General Reset	17F00h
Inverter Configuration Command 1	1FFD0h
Inverter Command	1FFD3h
Product Identification	0FEEBh
Request for DGN	0EA00h

Table 18 CAN Commands

CAN Continued

Status	DGN Number
Charger Configuration Status	1FFC6h
Charger Configuration Status 2	1FF96h
Charger Configuration Status 3	1FECCh
Charger Configuration Status 4	1FEBFh
Charger Equalization Status	1FF99h
Charger Status	1FFC7h
Charger Status 2	1FEA3h
Charger AC Status 1	1FFCAh
Charger AC Status 2	1FFC9h
Charger AC Status 3	1FFC8h
DC Source Status 1	1FFFDh
DC Source Status 2	1FFFCh
Inverter AC Status 1	1FFD7h
Inverter AC Status 3	1FFD5h
Inverter AC Status 4	1FF8Fh
Inverter DC Status	1FEE8h
Inverter Status	1FFD4h
DM RV	1FECAh
Communication Status 1	1FFFAh
Communication Status 2	1FFF9h
Communication Status 3	1FFF8h
Inverter Configuration Status 1	1FFD2h
Inverter Configuration Status 2	1FFD1h
Inverter Configuration Status 3	1FECEh
Inverter Configuration Status 4	1FE9Bh
Charger Equalization Configuration Status	1FF98h
Inverter AC Fault Configuration Status 1	1FF8Eh
Inverter AC Fault Configuration Status 2	1FF8Dh
MFG Specific Claim Request	1FED6h
Inverter Temperature Status	1FEBDh
Instance Status	17B00h

Table 19 CAN Status

LIMITED WARRANTY TERMS & CONDITIONS

SHIPPING TERMS: F.O.B. St. Paul Minnesota. Freight prepaid and billed, subject to prior credit approval.

MINIMUM ORDER: \$50.00 Net Price

LOSS OR DAMAGE: Loss or damage in transit are the responsibility of the carrier. Any claim should be filed with the delivering transport company. Invoice, Bill of Lading and Delivery receipt with damage noted therein must accompany any claims for freight damage. Claims for shortage and lost shipments must be made in writing to Sensata Technologies within 10 days of date of shipment. Claims not reported within this time frame will not be honored.

PRICES: Prices are subject to change without notice. All orders are subject to acceptance at the factory. We reserve the right to invoice prices in effect at time of shipment.

TERMS: Net 30 days with approved credit, credit card or C.O.D.

RETURN GOODS POLICY:

- No returned materials will be accepted without an accompanying Returned Materials Authorization Number (RMA) from the factory.
- Credit will be issued for returned goods to the original purchaser within 60 days of purchase, provided the inverter is returned to Sensata unused and not mounted. The amount of credit will be issued at Sensata's discretion based on the condition of the product.
- Customer must be in good standing with Sensata Technologies.
- Inverters that are discontinued, high-voltage (over 24 VDC), special-order or reconditioned are excluded and will not be eligible for credit. Non-inverter items such as cable assemblies, fuses and fuse holders, will not be eligible for credit
- Support components supplied by Sensata vendors will be covered under that manufacturer's credit return policy.
- Customer pays return freight.

PLEASE SHIP AUTHORIZED RETURNS TO:

Sensata Technologies RMA# _____, 4467 White Bear Parkway, St. Paul, MN 55110. Return Freight Prepaid.

LIMITED WARRANTY:

Sensata Technologies extends the following warranty to the original purchaser of those goods subject to the qualifications indicated. Sensata warrants to the original purchaser for use that the goods or any component thereof manufactured by Sensata will be free from defects in workmanship from the date of purchase for the period listed on the product label, provided such goods are installed, maintained and used in accordance with Sensata and the original manufacturer's written instructions. Damages caused by the misuse, undue care or obvious wear through use will not be covered by this warranty.

Components not manufactured by Sensata, but used within the assembly provided by Sensata, are subject to the warranty period as specified by the individual manufacturer of said component, provided such goods are installed, maintained and used in accordance with Sensata and the manufacturer's written instructions.

Sensata's sole liability and the Purchaser's sole remedy for a failure of goods under this limited warranty and for any and all claims arising out of the purchase and use of the goods shall be limited to the repair or replacement of the goods that do not conform to this warranty.

SENSATA RETURN PROCEDURE:

To obtain repair or replacement service under the limited warranty, the purchaser must contact the factory for a Return Material Authorization (RMA) Number. Once obtained, send the RMA Number along with the defective part or goods to:

Sensata Technologies RMA# _____, 4467 White Bear Parkway, St. Paul, MN 55110. Return Freight Prepaid.

THERE ARE NO EXPRESS WARRANTIES COVERING THESE GOODS OTHER THAN AS SET FORTH ABOVE. THE IMPLIED WARRANTIES OF MERCHANTABILITY AND FITNESS FOR A PARTICULAR PURPOSE ARE LIMITED IN DURATION TO ONE YEAR FROM DATE OF PURCHASE.

SENSATA TECHNOLOGIES ASSUMES NO LIABILITY IN CONNECTION WITH THE INSTALLATION OR USE OF THE PRODUCT, EXCEPT AS STATED IN THIS LIMITED WARRANTY. SENSATA TECHNOLOGIES WILL IN NO EVENT BE LIABLE FOR INCIDENTAL OR CONSEQUENTIAL DAMAGES.

WARNING: LIMITATIONS ON USE: DIMENSIONS™ brand products are not intended for use in connection with Life Support Systems and for Avionic use. Sensata Technologies® makes no warranty or representation in connection with their products for such uses.

Setting Notes

Low Battery	Min	Max		
	21.0 V	24.0 V		
	0.1 V Increments			
Battery Type	Wet <input type="checkbox"/>	AGM <input type="checkbox"/>	Gel <input type="checkbox"/>	LFP <input type="checkbox"/>
Battery Profile	1 <input type="checkbox"/>	2 <input type="checkbox"/>	3 <input type="checkbox"/>	4 <input type="checkbox"/>
Branch Circuit Rating	Disabled <input type="checkbox"/>	Min	Max	
		5 A	30 A	
	5 A Increments			
AC Line Qualify	Min	Max		
	5 Seconds	30 Seconds		
	5 Sec Increments			
CAN Instance	Min	Max		
	1	13		
CAN Baud Rate	250K <input type="checkbox"/>		500K <input type="checkbox"/>	
CV Timeout	Min	Max		
	0.5 Hrs	25.0 Hrs		
	0.25 Hr Increments			
CV VDC				
Float VDC				
Max Charge ADC				
Batt Amp Hour				
Batt Hi Temp SD (LFP Only)				
Batt Lo Temp SD (LFP Only)				
Batt Lo Temp Chg (LFP Only)				
Serial Number				
Date				

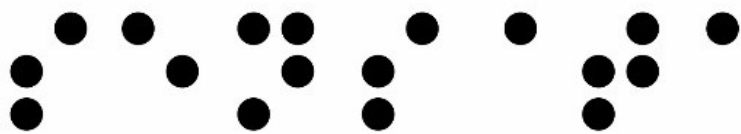

Sensata

Technologies

The World Depends on Sensors and Controls