

NO.	DESCRIPTION
1	ASSY, FLASHING, MILL OR BLACK
2	ASSY, CAP, MILL OR BLACK
3	BOLT LAG 5/16 X 4.75"
4	WASHER, EPDM BACKED

KIT, FLASHFOOT2®		
SIZE <b>A</b>	DO NOT SCALE DRAWING	
SCALE: 1:4	WEIGHT: 0.88 lbs	SHEET 1 OF 1

# Installation

**Tools Required:** tape measure, chalk line, stud finder, roofing bar, caulking gun, driver with 1/4" bit and 7/16" hex socket.

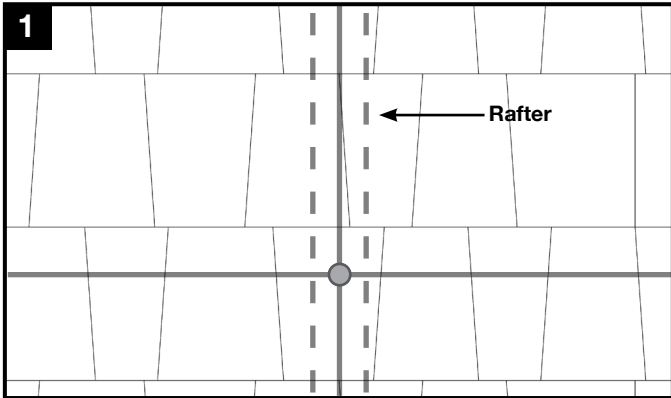

Locate rafters and snap vertical and horizontal lines to mark flashing locations. Drill 1/4" pilot holes, then fill with roofing manufacturer's approved sealant.

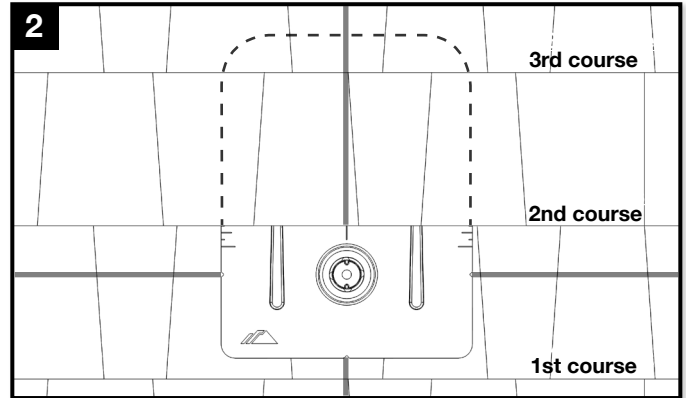

Slide flashing, between 1st and 2nd course, so the top is at least 3/4" above the edge of the 3rd course and the bottom is above the edge of the 1st course.

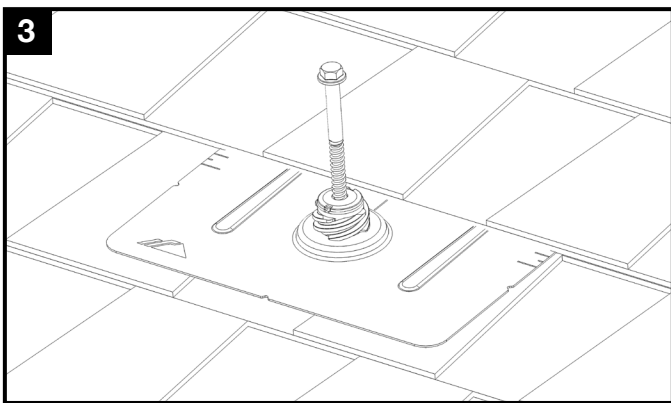

Line up pilot hole with flashing hole and insert lag bolt with bonded washer through flashing. Tighten lag bolt until fully seated.

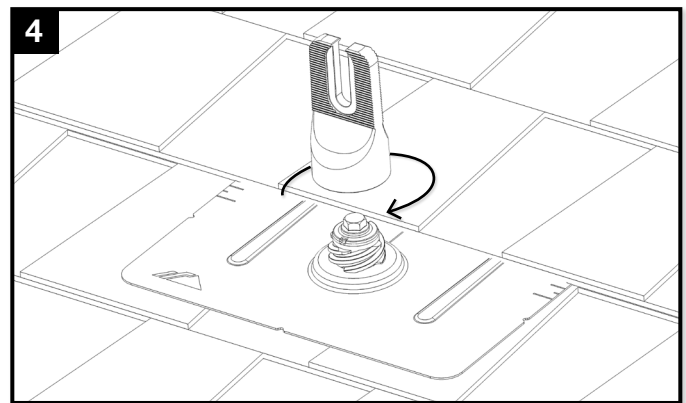

Place Cap onto flashing in desired orientation for E/W or N/S rails and rotate 180 degrees. FlashFoot 2 is now installed and ready for IronRidge XR Rails.

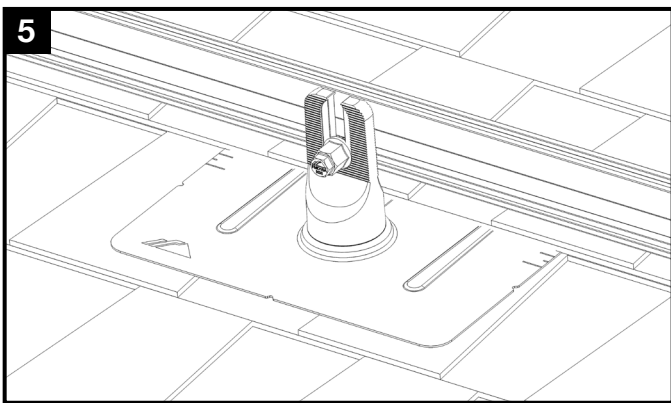

Attach rails to either side of the open slot using bonding hardware. Level rail at desired height, then torque to 250 in-lbs (21 ft-lbs).

## Structural Certification

Designed and Certified for Compliance with the International Building Code & ASCE/SEI-7.

## Water Seal Ratings

Water Sealing Tested to UL 441 Section 27 "Rain Test" and TAS 100-95 "Wind Driven Rain Test" by Intertek. Ratings applicable for composition shingle roofs having slopes between 2:12 and 12:12. Tested and evaluated without sealant. Any roofing manufacturer approved sealant is allowed.

## UL 2703

Conforms to UL 2703 Mechanical and Bonding Requirements. See IronRidge Flush Mount Installation Manual for full ratings.