

Solar, Sleeker Than Ever

Most solar installations use mounting rails and fasteners to secure modules to the building structure, but these critical components often protrude from the sides of the modules, giving arrays a coarse look.

CAMO is an invisible fastener that secures solar modules flush to rail ends, creating a clean, sleek appearance. CAMO works with nearly all solar modules and installs without tools or torque specifications. It simply rotates into place to structurally secure and electrically bond with the module.

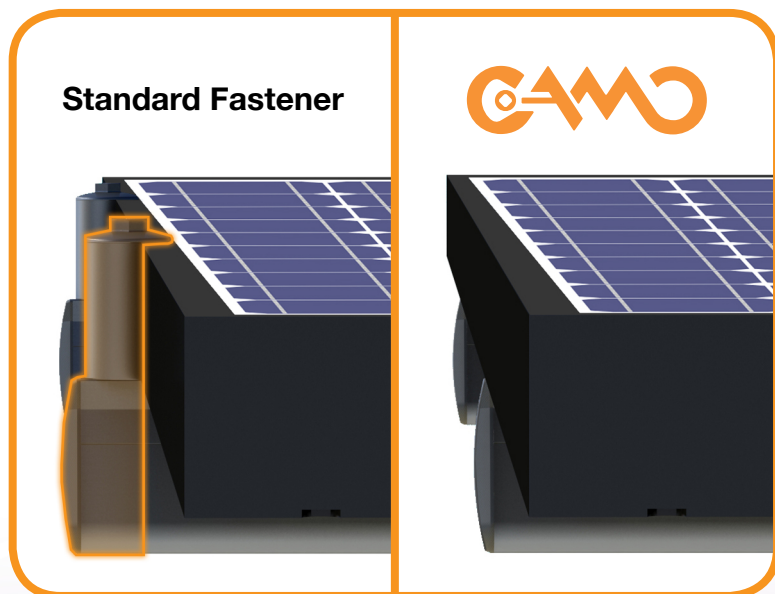

Cam-Locking Design

CAMO's unique design allows for a completely tool-less installation. Simply slide CAMO into the rail track and rotate the ergonomic handle 90 degrees to lock onto the module frame. It's that easy.



Certified to comply with International Building Code, ASCE/SEI-7, and UL 2703 Mechanical and Bonding Requirements.

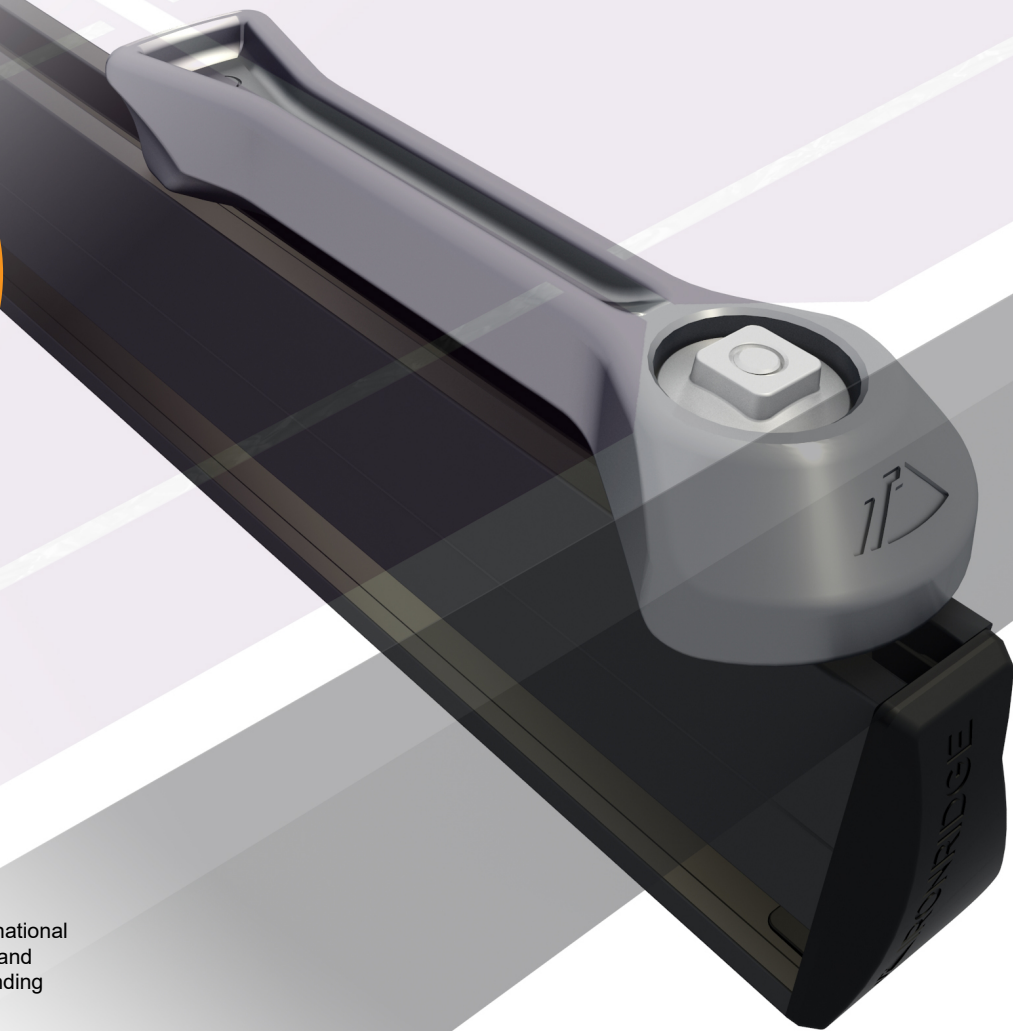

Easy, Tool-Less Installation

A. PLACE CAMO

Slide CAMO into rail track far enough to clear the module frame. CAMO requires 6" of clearance from end of rail.

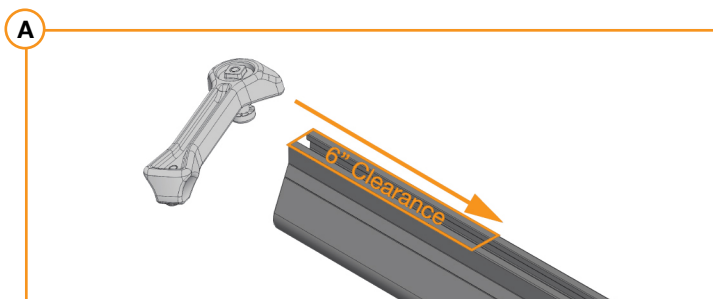

B. PLACE MODULE

Place module on rails and align flush with rail ends (module cells not shown in image to provide clarity). The module can overhang the rail no more than 1/4".

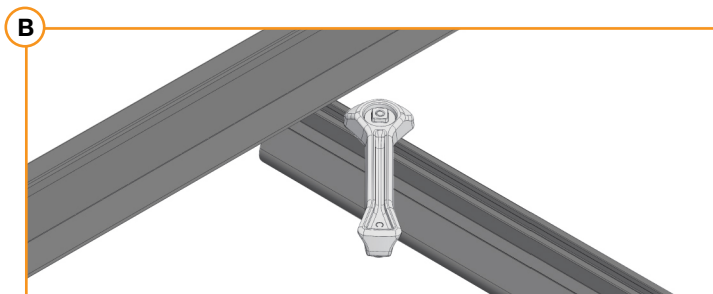

C. SLIDE CAMO

Pull CAMO towards rail end, at a 45 degree angle, so linear bonding pin contacts the module flange edge.

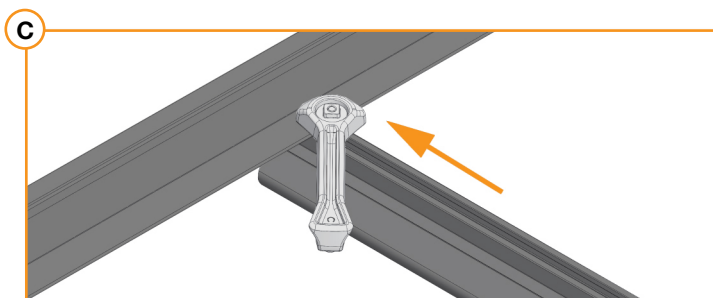

D. SECURE CAMO

Rotate handle with an upwards motion until CAMO snaps into rail track. Ensure CAMO bonding pins are fully seated on top of module frame.

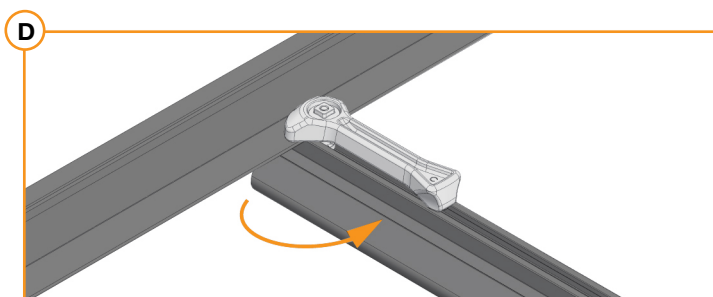

Tested & Certified

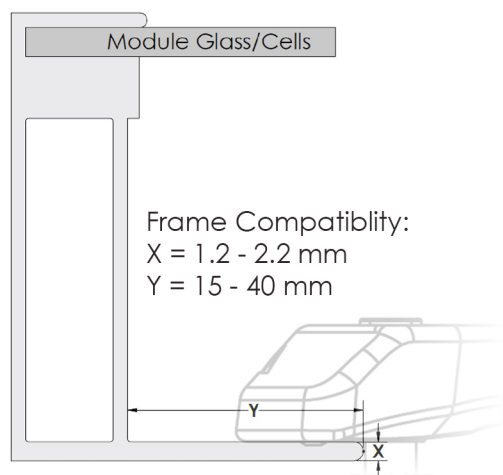

UL 2703

CAMO conforms to STD UL 2703 (2015) requirements and fits modules with bottom flanges that meet specifications shown in the frame compatibility diagram on the left.

See IronRidge Installation Manuals for full ratings and a list of certified compatible modules.

