

# COTEK

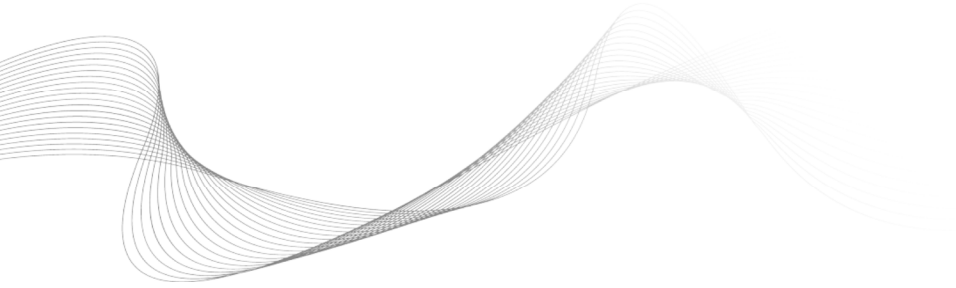

## ***TR-40 User's Manual***

*40A Transfer Switch*

# Table of Content

---

<b>1. IMPORTANT SAFETY INFORMATION</b>	<b>1</b>
1-1.General Safety Precautions	1
1-2.Other Safety Notes	1
<b>2. INTRODUCTION</b>	<b>2</b>
2-1. System	2
2-2. Application Block Diagram	2
2-3. Panel introduction and terminal description	2
2-4. LED status	4
2-5. Electrical Specification	4
2-6. Mechanical Drawings	5
2-7. Standard Accessory	6
<b>3. INSTALLATION AND OPERATION</b>	<b>6</b>
<b>4. TROUBLESHOOTING</b>	<b>10</b>
<b>5. WARRANTY</b>	<b>10</b>

# 1. Important Safety Information

## 1-1. General Safety Precautions



**Warning!** Before using the Inverter, read the safety instructions.

- Do not expose the transfer switch to rain, snow, spray or dust. To reduce the risk of fire hazard, do not cover or obstruct the ventilation openings and do not install the inverter in a zero-clearance compartment.
- To avoid the risk of fire and electric shock, make sure that the existing wiring is in good electrical condition, and the wire size is not undersized.
- This equipment contains components which can produce arcs or sparks. To prevent fire or explosion, do not install in compartment containing batteries or flammable materials or in location which require ignition protected equipment. This includes any space containing gasoline-powered machinery, fuel tanks, or joints, fittings, or other connection between components of the fuel system.
- The following precautions should be taken when working on the transfer switch:
  - Step 1 Remove watches, rings, or other metal objects
  - Step 2 Use tools with insulated handles
  - Step 3 Wear rubber gloves and boots

## 1-2. Other Safety Notes

- Upon receipt, examine the carton box for damage. If you have found any damage on the carton box please notify the company you purchased this unit from.
- Do not operate near water or in excessive humidity.
- Install the transfer switch in a well-ventilated area. Do not block the front air vents, or the rear air exhausts of the unit.
- Do not operate the transfer switch close to combustible gas or open fire.

## 2. Introduction

### 2-1. System

The unit is a highly reliable transfer switch, designed with advanced power electronic and microprocessor. Below are main features:

- Low power consumption <1.4W
- Universal AC input, full range
- Cooling by free air convection
- Switching current up to 40 amps
- High transfer speed
- Applicable models: SP-700/1000/1500/2000/3000/4000

### 2-2. Application Block Diagram

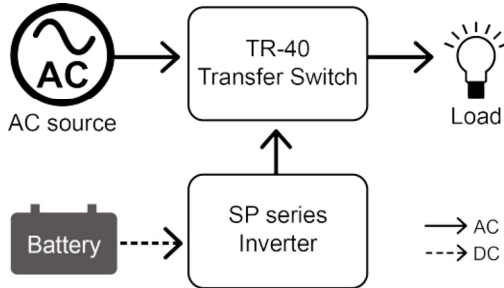

Fig. 1 Application block diagram

### 2-3. Panel introduction and terminal description

#### 2-3-1. Panel introduction

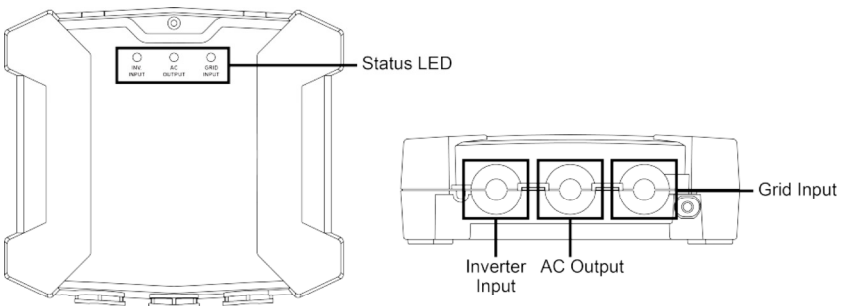

Fig. 2 Panel introduction

## 2-3-2. Terminal description

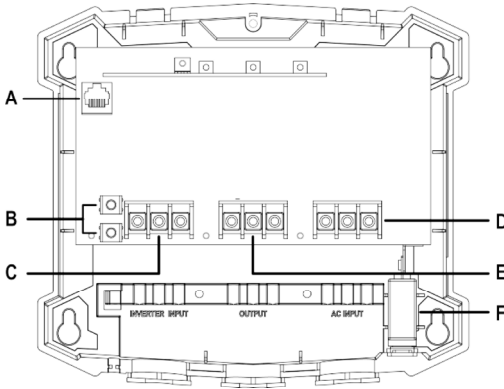

Fig. 3 Terminal description

	Description	Function
A	TRC Port (RJ-45)	SP series inverter communication port
B	N terminal	N to ground
C	Inverter Input terminal	Inverter AC power input terminal
D	AC Input terminal	Grid AC power input terminal
E	Output terminal	Output power terminal
F	Circuit Breaker (40A)	Grid power over load protection

Table 1. Panel introduction and terminal description

## 2-3-3. TRC port definition

Pin Num.	Definition	
1	Reserved	--
2	PH-L	Zero-crossing signal
3	PH-N	Zero-crossing signal
4	Bypass	transfer switch driver signal
5	12V	Internal power for TR-40 controller
6	5V	Internal power for TR-40 controller
7	GND	The same polarity and the negative battery
8	Reserved	--

Table 2. TRC port definition

## 2-4. LED status

### 2-4-1. INV. INPUT

LED	Signal Description
Green	Inverter input normal
Red	Inverter not synchronous
Off	No Inverter input

Table 3. INV. input LED description

### 2-4-2. AC OUTPUT

LED	Signal Description
Green	INV provides power to Load
Orange	Grid provides power to Load
Off	No AC output

Table 4. AC output LED description

### 2-4-3. GRID INPUT

LED	Signal Description
Green	Grid input normal
Red	Grid not synchronous
Off	No Grid input

Table 5. GRID input LED description

## 2-5. Electrical Specification

Model		TR-40	
Contact Rating	Max. switching voltage	277VAC	
	Max. switching current	40A	
	Max. switching power	11000VA	
	Switching time	INV to GRID	10mS
		GRID to INV	60mS
Control	Voltage range	100~240VAC	
	AC current (Typ.)	21mA / 100VAC, 16mA / 240VAC	
	Frequency range	47~63Hz	
	Power consumption	<1.4W (at no load)	
Protection	Wiring errors	LED inform	
	Grid overload	Circuit breaker (40A)	

Model		TR-40
Environment	Working temp.	-20°C ~40°C
	Working humidity	20~85% RH non-condensing
	Storage temp., humidity	-40°C ~85°C, 20~85%
	Vibration	10~500Hz, 2G 10min / 1 cycle, period for 60 min each along X,Y,Z axes
Safety & EMC	Safety standards	Certified EN60947-1; EN60947-6-1
	EMI	Certified EN55022
	Power harmonic & voltage fluctuation and flicker	Certified EN61000-3-2, EN61000-3-3
	EMS immunity	Certified EN55024, IEC61000-4-2, 3, 4, 5, 6, 8, 11
Others	Relay	2
	Dimension (WxHxD)	220x71x194 mm / 8.66x2.80x7.64 inch

Table 6. TR-40 Electrical Specification

## 2-6. Mechanical Drawings

Unit: mm [inch]

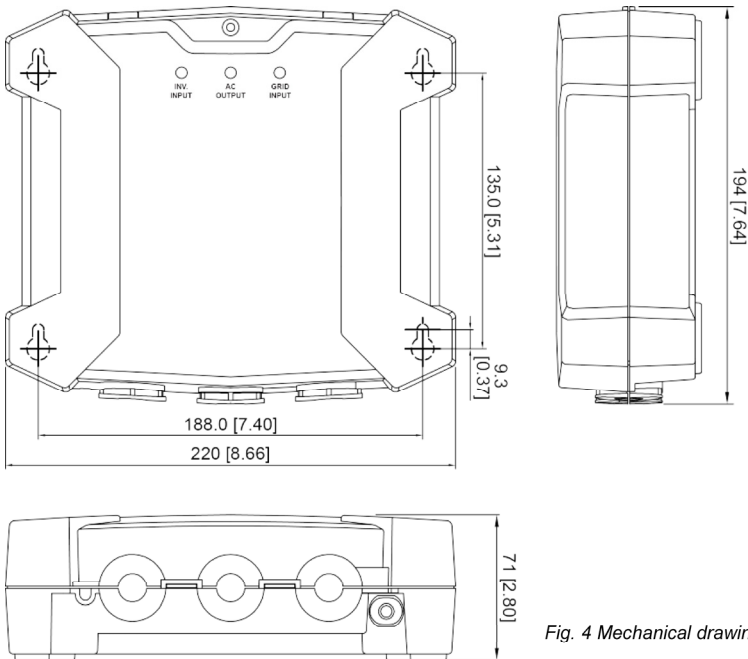

Fig. 4 Mechanical drawings

## 2-7. Standard Accessory

TRC Cable, 1800mm x 1pcs  
Copper for N Terminal x 1pcs

## 3. Installation and Operation

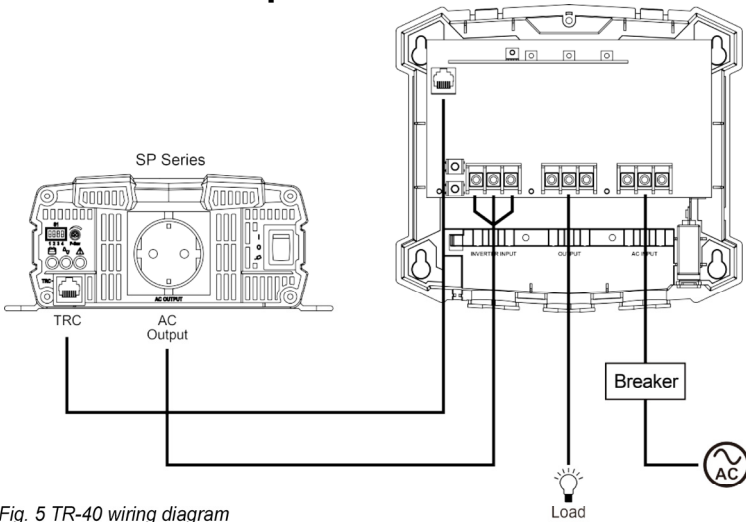

Fig. 5 TR-40 wiring diagram

**Note 1:** Please make sure the load power consumption is not over inverter output power.

**Note 2:** Please make sure the inverter output settings (output voltage and frequency) should be the same as the Grid power.

**Step 1** Please follow the installation drawing to connect the TR-40, inverter, load and Grid power.

A. Use screw driver to lose the screw on the cover and remove the cover

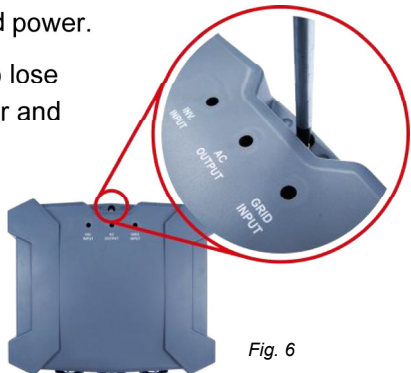

Fig. 6



B. Use screw driver to lose the layering

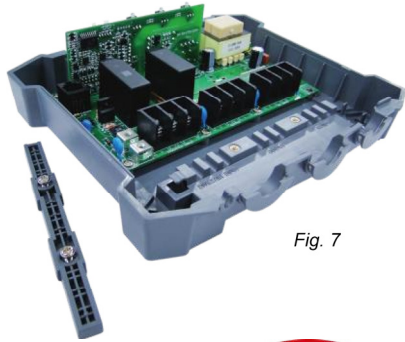

Fig. 7

C. Connect the cable

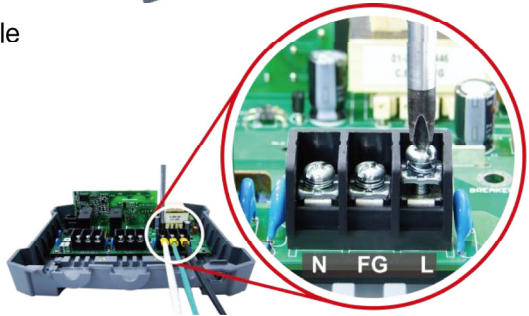

Fig. 8

D. Fix the layering and the cable.

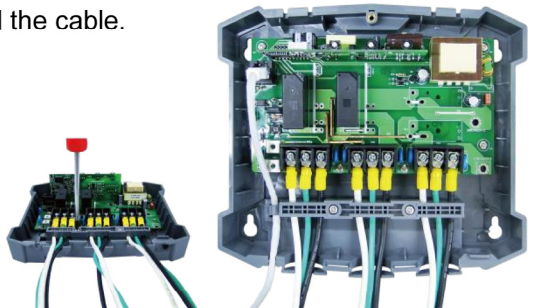

Fig.9

E. Fix the cover and connect the cable to inverter, load and Grid power.  
(Please refer to Fig.1 wiring diagram)



Fig. 10

**Step 3** Turn on the inverter power to make sure the inverter is working normally and then turn off the inverter.

**Step 4** Switch on the breaker to provide power to TR-40.

**Step 5** Turn on the inverter. When power on the inverter, it will take 15 seconds for frequency and phase locking. After frequency and phase is locked, the internal relay will switch to “Grid input”. The LED of “AC OUTPUT” will turn orange. Grid AC provides the energy to the load. The system works normal.



**Note!** In case AC OUTPUT do not switch, please follow the troubleshooting guide.



### **Warning!**

1. Before the wiring connection, it's important to make sure there is no power feed in and inverter must be switched off.
2. Wire diameter: user need to use / select the suitable cable gauge. Please contact the COTEK distributor for installation.
3. TR-40 max. output current is 40A and please use 40Ax1.25= 50A to select the cable.

Consider the two important factors to decide the cable size :

- NEC Table 310.15(B)(2)(A) Ambient Temperature Correction Factors Based on 30°C.
- NEC 310.15(B)(16) Allowable Ampacities of Insulated Conductors Rated Up to and Including 2000 Volts, 60°C Through 90°C , Not More Than Three Current-Carrying Conductors in Raceway, Cable, or Earth(Directly Buried), Based on Ambient Temperature of 30°C .

COTEK suggest user to select the AWG#6 for TR-40.

In case the application do not need such high current, user can determine the cable based on the following table.

Ambient Temperature (°C)	Temperature Rating of Conductor			Ambient Temperature (°F)
	60°C	75°C	90°C	
10 or less	1.29	1.20	1.15	50 or less
11-15	1.22	1.15	1.12	51-59
16-20	1.15	1.11	1.08	60-68
21-25	1.08	1.05	1.04	69-77
26-30	1.00	1.00	1.00	78-86
31-35	0.91	0.94	0.96	87-95
36-40	0.82	0.88	0.91	96-104

Table 7. NEC Table 310.15(B)(2)(A) Ambient Temperature Correction Factors Based on 30°C.

A.W.G	Copper Temperature		
	60°C	75°C	90°C
	Current (A)		
14	15	20	25
12	20	25	30
10	30	35	40
8	40	50	55
6	55	65	75

Table 8. NEC 310.15(B)(16) Allowable Ampacities of Insulated Conductors Rated Up to and Including 2000 Volts, 60°C Through 90°C, Not More Than Three Current-Carrying Conductors in Raceway, Cable, or Earth(Directly Buried), Based on Ambient Temperature of 30°C.

## 4. Troubleshooting

LED Status	Signal Description	Suggestion actions
Grid and Inverter Input LED Red twinkling	Grid not synchronous	Please power off the system by disconnecting both Grid & Inverter power. Please check the Inverter input cable and make sure the cable correctly connecting at L and N wiring terminal.
Grid Input LED Off	No Grid input	Please power off the system by disconnecting both Grid & Inverter power and make sure the Grid input cable are connected correctly.
INV input LED Red	Inverter not synchronous	Please power off the system by disconnecting both Grid & Inverter power. Please make sure the Inverter input cable and TRC cable are connected correctly.
INV input LED Off	No Inverter input	Please power off the system by disconnecting both Grid & Inverter power. Please check the inverter status – On / Off Also, make sure the inverter input and TRC cable are connected correctly.
All LED off	No Power	Check TR-40 input and TRC cable.

Table 9. Troubleshooting guide

## 5. Warranty

We guarantee this product against defects in materials and workmanship for a period of 24 months from the date of purchase. In case you need to repair or replace any defective power inverters, please contact COTEK local distributor.

This warranty will be considered void if the unit has been misused, altered, or accidentally damaged. COTEK is not liable for anything that occurs as a result of the user's fault.

# COTEK

---

No.33, Sec. 2, Renhe Rd., Daxi Dist., Taoyuan City 33548, Taiwan

Phone : +886-3-3891999    FAX : +886-3-3802333

[http : // www.cotek.com.tw](http://www.cotek.com.tw)

2016.03.\_A4